

EBE 85

CATALOGO
TECNICO
TECHNICAL
CATALOGUE

METALFORM
versione 04/2023

The logo for Secco, featuring the word "secco" in white lowercase letters on a red trapezoidal background.

secco

1	Informazioni generali / General informations	
	Descrizione del sistema / System description	1.1.1
	Tipologie e limiti dimensionali / Typologies and dimensional limits	1.2.1 – 1.2.3
2	Componenti del sistema / System component	
	Profili / Profiles	2.1.1 – 2.1.4
	Accessori / Accessories	2.2.1 – 2.2.6
	Ferramenta / Hardware	2.3.1 – 2.3.12
	Squadrette / Corner joint	2.4.1 – 2.4.4
	Maniglie / Handles	2.5.1 – 2.5.3
	Guarnizioni / Gaskets	2.6.1 – 2.6.3
	Attrezzature / Working tools	2.7.1 – 2.7.3
	Prodotti / Products	2.8.1 – 2.8.2
	Fermavetri / Glazing beads	2.9.1 – 2.9.12
	Dividivetro / Glazing beads	2.10.1 – 2.10.2
3	Tecnica del sistema / System technique	
	Sezioni porte / Doors sections	3.1.1 – 3.1.11
	Sezioni finestre / Windows sections	3.2.1 – 3.2.7
	Attacchi alla muratura / Attachment to structure	3.3.1 – 3.3.5
4	Lavorazioni e ciclo produttivo / Processing plan	
	Distinte di taglio / Cutting list	4.1.1 – 4.1.20
	Assiemaggio / Assembly	4.2.1 – 4.2.24
	Lavorazione e applicazione accessori porte / Working and installation of door accessories	4.3.1 – 4.3.44
	Lavorazione e applicazione accessori finestre / Working and installation of window accessories	4.4.1 – 4.4.72
5	Note generali sul processo / Processing general informations	
	Raccomandazioni per la lavorazione / Working recommendations	5.1.1 – 5.1.6
	Taglio, asolature, forature / Cutting, slots, holes	5.2.1 – 5.2.2
	Verifica qualità / Quality audit cycle	5.3.1
	Caratteristiche materiali / Materials characteristic	5.4.1 – 5.4.2
	Indice analitico / Subject index	5.5.1 – 5.5.2

Sistema integrato di profili, accessori e guarnizioni a taglio termico con profili aventi sezione di 85 mm e/o 93.5 mm, idoneo per la realizzazione di porte e finestre, rettangolari, sagomate o curve con o senza fissi laterali e superiori.

I profili in metallo componenti il sistema sono dello spessore di 15/10 mm e sono ottenuti tramite profilatura a freddo di nastri nei vari materiali previsti dal sistema.

Il taglio termico dei profili è realizzato tramite un estruso in poliammide rinforzato con fibra di vetro reso solidale alle parti in metallo esterne da una resina poliuretana ad alta densità, iniettata ad alta pressione. Il collegamento che si ottiene è continuo, privo di interruzioni e garantisce la massima resistenza torsionale e flettente.

La costruzione dei telai prevede l'unione tra i profili tramite saldatura in continuo delle sezioni in contatto e la successiva ripresa delle superfici in vista, o l'utilizzo di un sistema misto ad assemblaggio meccanico a saldatura interna che non necessita di riprese di finitura.

Il sistema prevede al possibilità di alloggiare vetri singoli o stratificati (di sicurezza) a una o più camere.

Sistema porte:

Coplanarità delle ante;

Doppia guarnizione di tenuta per elevate caratteristiche prestazionali e acustiche;

Completa dotazione di accessori negli stessi materiali del profilo;

Cerniere a saldare, avvitare e a scomparsa per grandi portate;

Maniglie con diverse soluzioni estetiche;

Paraspifferi inferiore con guarnizione a pinna.

Sistema finestre:

Coplanarità esterna e sormonto interno delle ante;

Sistema di guarnizioni a giunto aperto per le massime prestazioni di resistenza all'aria, acqua e vento ed elevati valori di resistenza acustica;

Idonea camera porta-accessori per l'alloggiamento di ferramenta certificata e per la riduzione dei tempi di lavorazione;

Sistema integrato completo di accessori per lo scarico acqua;

Completa dotazione di accessori:

Ferramenta per apertura ad anta, anta ribalta, vasistas per serramenti rettangolari, trapezoidali e curvi fino a 150 kg;

Ferramenta per cerniere a scomparsa.

Integrated system of thermally broken profiles, hardware and gaskets with 85 mm and 93.5 mm sections, suitable for rectangular, profiled or arched doors and windows, with or without sidelights and upper lights.

The metal profiles that make up the system are 15/10 mm thick and are obtained from the cold-forming of the coils in the various materials available.

The thermal break of the profiles is realized with an extruded polyamide reinforced with fibre-glass that is collocated flush with the external parts in metal by means of a high-density polyurethane resin injected at high pressure. The result is a seamless connection without interruptions which guarantees maximum resistance to torsional and bending stress.

For frame assembly the profiles must be joined by welding the sections in contact with each other, or by mechanically assembling and then internally welding which does not need finishing touches. Double or triple thermally insulated glazing may be used with single or stratified (safety) glass.

Doors system:

coplanarity of the doors;

double sealing gasket for high performance and acoustics;

complete with accessories in same material as profile;

hinges to be welded, screwed or concealed for large capacities;

selection of handles with different aesthetic solutions;

lower seal with fin.

Windows system:

external coplanarity and internal overlap of the leaves;

system of open joint gaskets for maximum resistance to air,

water and wind, as well as high levels of acoustic resistance;

hardware container to keep all certified hardware and reduce time required for tooling;

integrated system complete with accessories for drainage of water;

all accessories furnished:

hardware for side hung opening, tilt and turn, bottom-hung windows

for rectangular, trapezoidal and arched fixtures up to 150 kg.

hardware for concealed hinge

PRESTAZIONI

Sistema finestre

Trasmittanza termica (UNI EN 10077-2)

-Nodo tipo (acciaio inox) con $U_f = 2,1 \text{ W/m}^2\text{K}$

-Finestra tipo (1230x1480 mm con $U_g 0,6$) $U_w = 1,1 \text{ W/m}^2\text{K}$

Isolamento acustico (UNI EN 717-1)

-Fino a 47 dB

Resistenza all'aria (UNI EN 12207)

-Classe 4

Resistenza all'acqua (UNI EN 12208)

-Classe 9A

Resistenza al vento (UNI EN 12210)

-Classe C5

Resistenza alla forza di azionamento (UNI EN 13115)

-Classe 1 – < 100 N

Prova carico verticale e torsione statica (UNI EN 13115)

-Classe 4 – 800 N / 350 N

Prova di durata a cicli di apertura (UNI EN 12400)

-Classe 2 - 10.000 cicli

PERFORMANCES

Windows system

Thermal transmittance (UNI EN 10077-2)

-Typical section (stainless steel) with $U_f = 2,1 \text{ W/m}^2\text{K}$

-Typical window (1230x1480 mm with $U_g 0,6$) $U_w = 1,1 \text{ W/m}^2\text{K}$

Acoustic insulation (UNI EN 717-1)

-Up to 47 dB

Air resistance (UNI EN 12207)

-Class 4

Watertightness (UNI EN 12208)

-Class 9A

Resistance to wind load (UNI EN 12210)

-Class C5

Resistance to drive force (UNI EN 13115)

-Class 1 – < 100 N

Test for vertical load and static torsion (UNI EN 13115)

-Class 4 – 800 N / 350 N

Resistance to repeated opening and closing (UNI EN 12400)

-Class 2 – 10.000 opening and closing

Limiti dimensionali - Maximum dimension

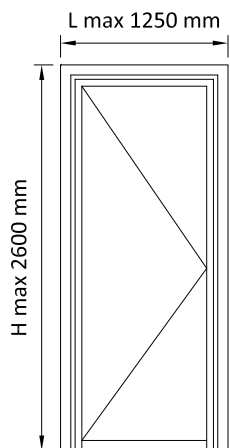

porta ad un'anta
one-leaf doors

peso massimo anta*
*maximum leaf weight**

- AC1033 - 160 kg
- AC1068 - 180 kg
- AC6023 - 200 kg
- AC1037 - 250 kg

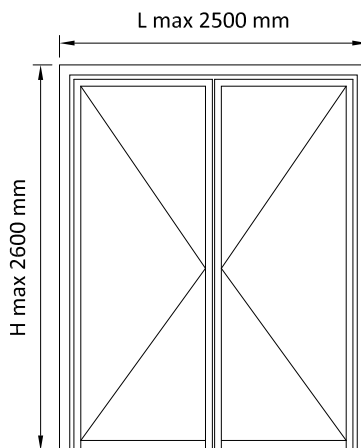

porta a due ante
two-leaf doors

peso massimo anta*
*maximum leaf weight**

- AC1033 - 160 kg
- AC1068 - 180 kg
- AC6023 - 200 kg
- AC1037 - 250 kg

* cerniera aggiuntiva per H serramento > 2200 mm
additional hinge for doors with height > 2200 mm

Esempi tipologie realizzabili - Types of door

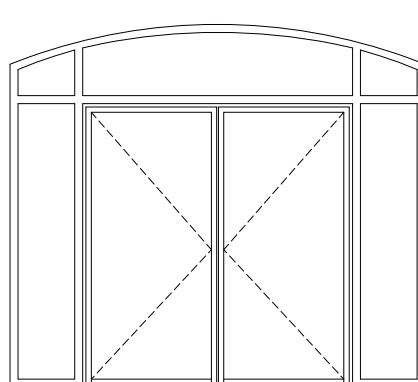
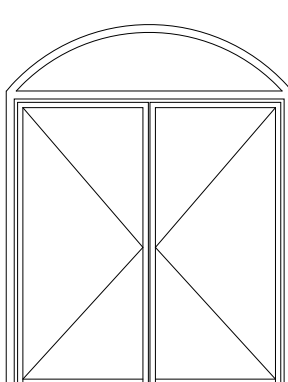
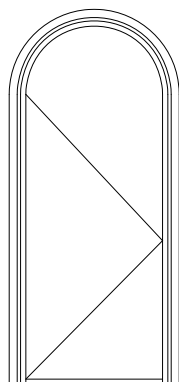
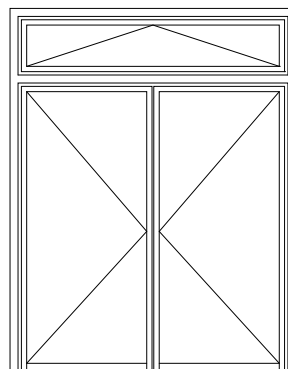
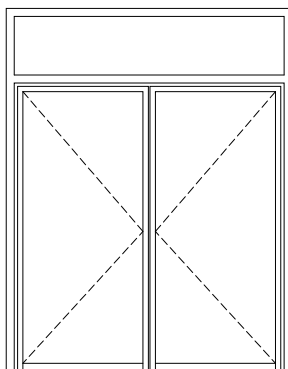
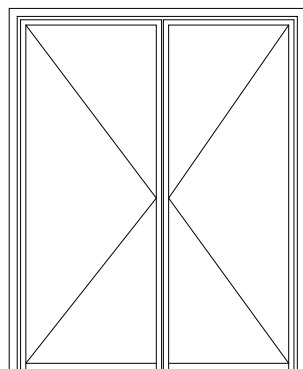
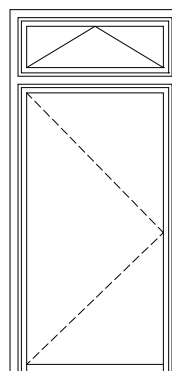
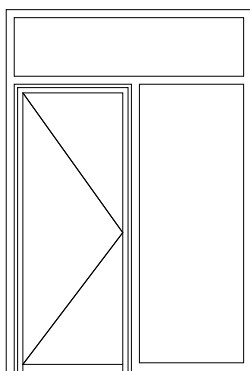
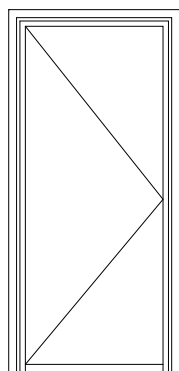

Limiti dimensionali - Maximum dimension

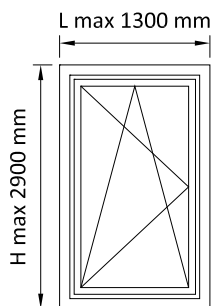

finestra ad un anta
one-leaf opening windows

peso massimo anta
maximum leaf weight

- AC1237 - 180 kg
- AC2632/C - 80 kg
- AGE271-2 - 150 kg Easy
- AG1273 - 80 kg Easy
- AG1278 - 80 kg Easy
- AGE281-2 - 130 kg Easy
- AGE291-2 - 130 kg Easy
- AGA271 - 180 kg Easy
- AG1271-2 - 150 kg RC2
- AG1281-2 - 130 kg RC2
- AG1291-2 - 130 kg RC2

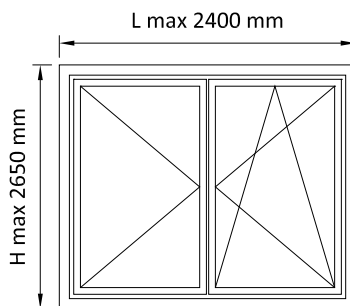

finestra a due ante
two-leaf opening windows

peso massimo anta
maximum leaf weight

- AC1237 - 180 kg
- AC2632/C - 80 kg
- AGE271-2-5-6 - 150 kg Easy
- AG1273 - 80 kg Easy
- AG1278 - 80 kg Easy
- AGE281-2-5-6 - 130 kg Easy
- AGE291-2-5-6 - 130 kg Easy
- AGE775-6 - 150 kg Easy
- AGE785-6 - 130 kg Easy
- AGE795-6 - 130 kg Easy
- AGA271-5 - 180 kg Easy
- AG1271-2-5-6 - 150 kg RC2
- AG1281-2-5-6 - 130 kg RC2
- AG1291-2-5-6 - 130 kg RC2

Esempi tipologie realizzabili - Types of window

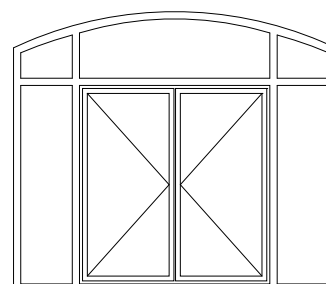
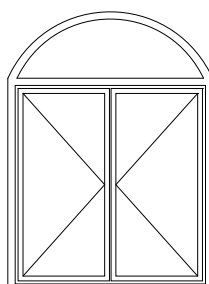
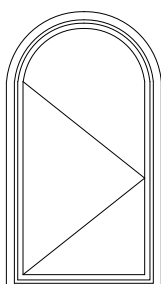
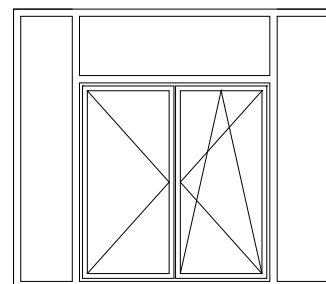
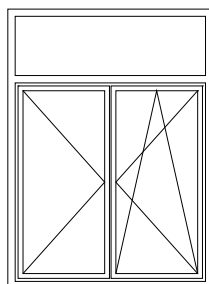
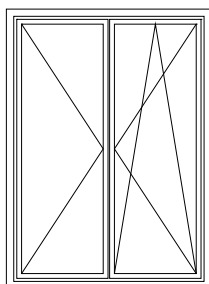
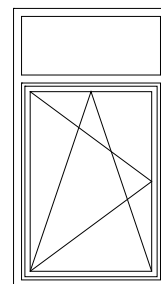
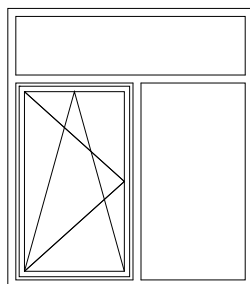
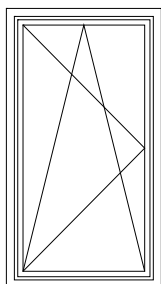

Limiti dimensionali - Maximum dimension

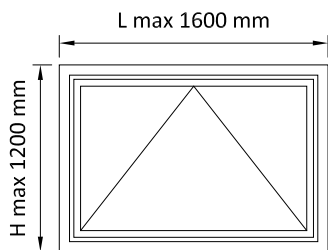

finestra a vasistas
bottom-hung window

peso massimo anta
maximum leaf weight

- AG1264 - AG1274
- AC2632/C - 100 kg
- AC1221 - 100 kg
- AG1224 - 100 kg

ferramenta e cremonese
hardware and cremone

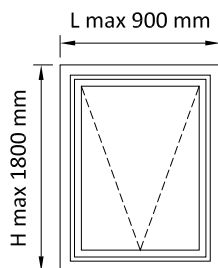

finestra a sporgere
awning window

peso massimo anta
maximum leaf weight

- AC1046 - 75 kg
- AC1046M - 120 kg

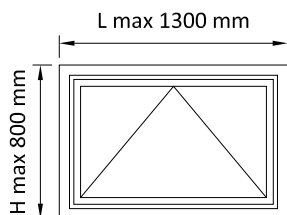

finestra a vasistas
bottom-hung window

peso massimo anta
maximum leaf weight

- AC1235
- AC2632/C - 70 kg
- AC1221 - 70 kg
- AG1224 - 70 kg

braccetti e cricchetto
stays and finger catch

Esempi tipologie realizzabili - Types of window

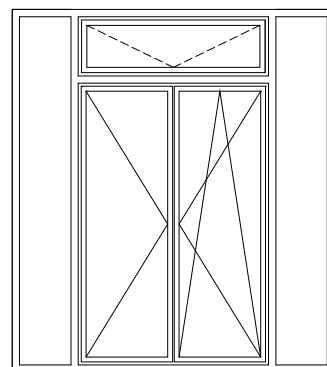
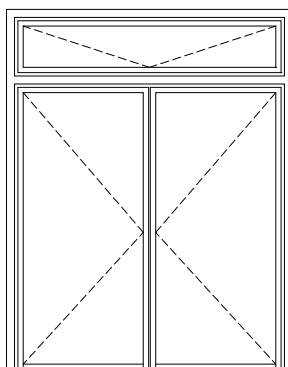
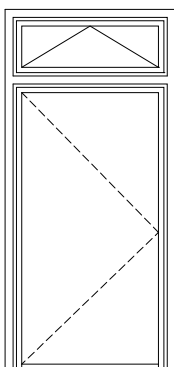
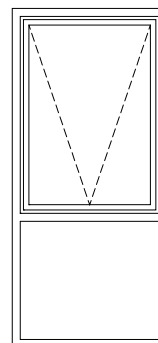
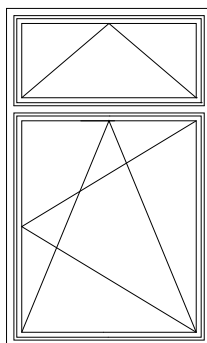
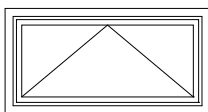

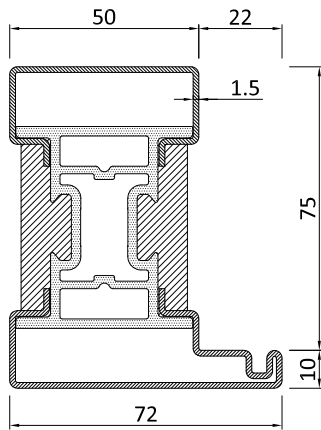

PR1101

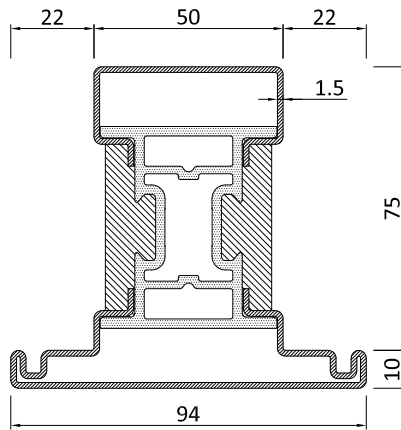

PR1102

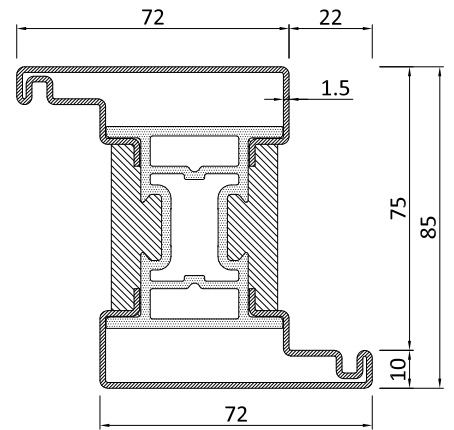

PR1103

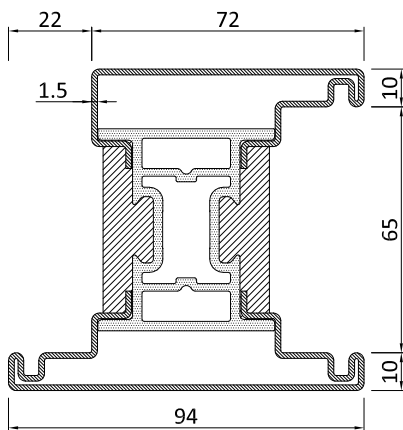

PR1105

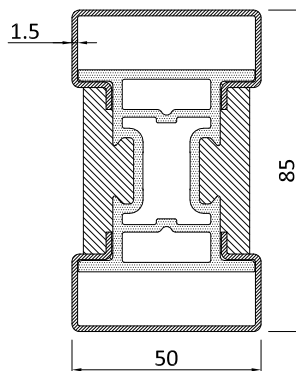

PR1110

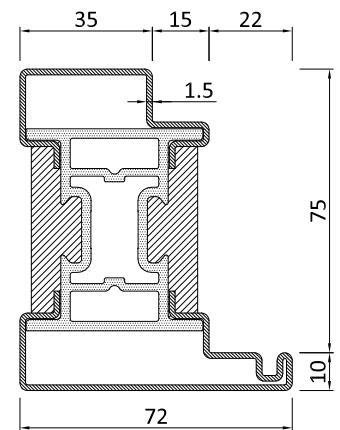

PR1111

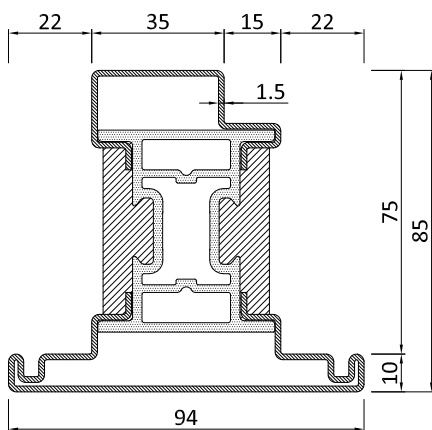

PR1112

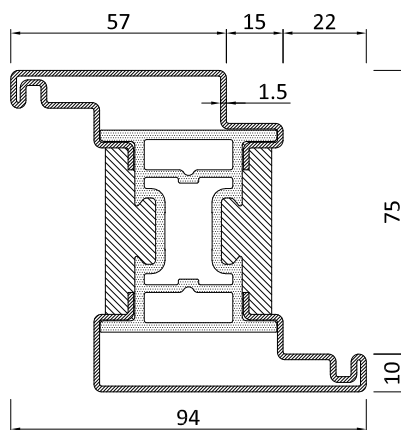

PR1113

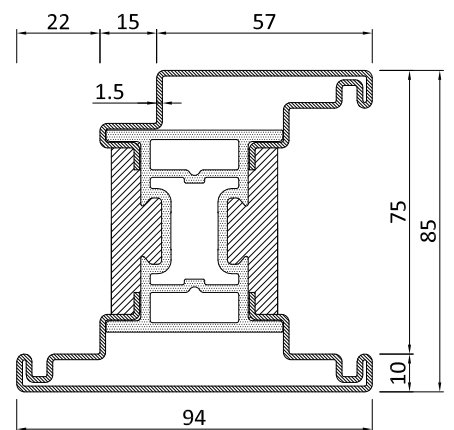

PR1115

Profilo / Profile n°	P Kg/m		A m ² /m	Jx cm ⁴	Jy cm ⁴	L m	Profilo / Profile n°	P Kg/m		A m ² /m	Jx cm ⁴	Jy cm ⁴	L m
	ZN / I - CT	OT						ZN / I - CT	OT				
PR1101	5,12	5,40	0,33	35,21	21,92	6	PR1111	5,08	5,36	0,33	33,26	21,11	6
PR1102	5,74	6,07	0,38	38,44	37,36	6	PR1112	5,71	6,03	0,38	36,33	36,25	6
PR1103	5,74	6,07	0,38	41,74	34,49	6	PR1113	5,74	6,06	0,38	40,28	338	6
PR1105	6,36	6,74	0,43	45,99	47,37	6	PR1115	6,36	6,73	0,43	44,39	45,72	6
PR1110	4,50	4,73	0,28	30,13	12,17	6							

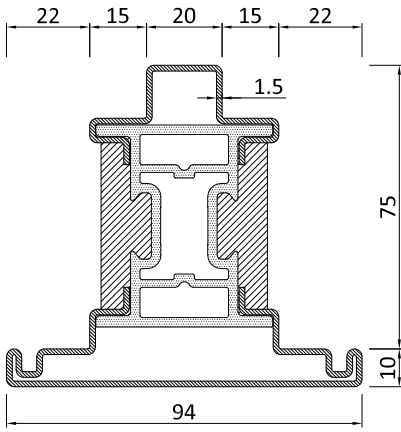

PR1122 Non fornito in acciaio zincato
Not in galvanized steel

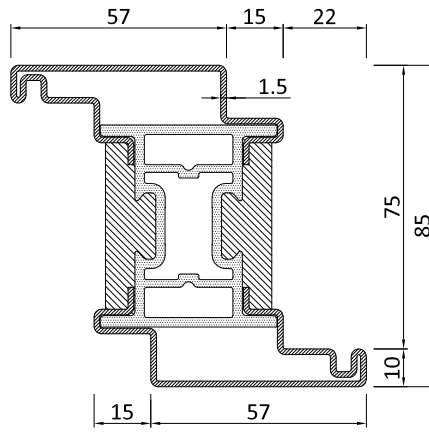

PR1123

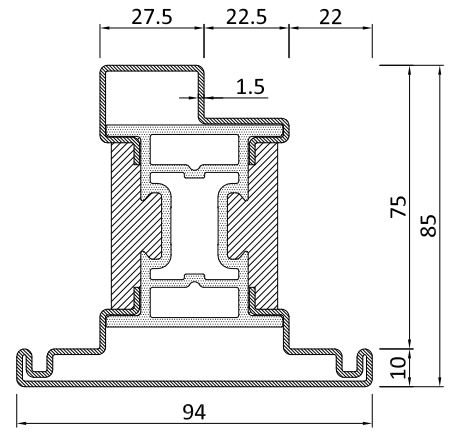

PR1127

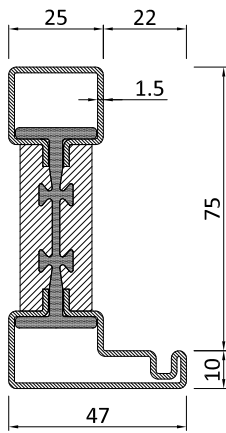

PR1301

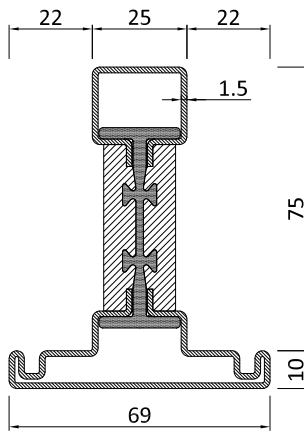

PR1302

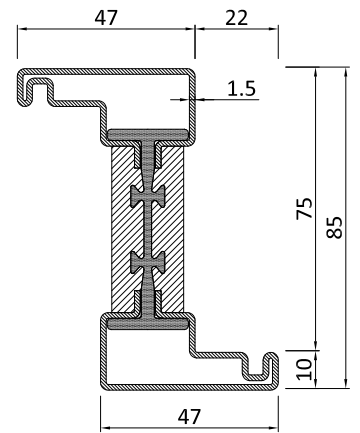

PR1303

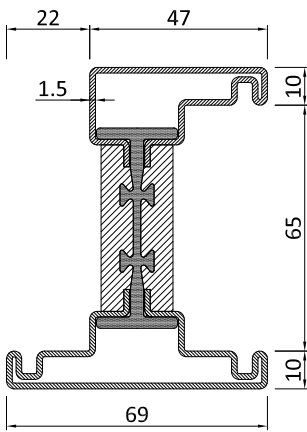

PR1305

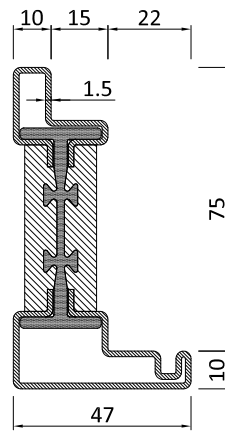

PR1311

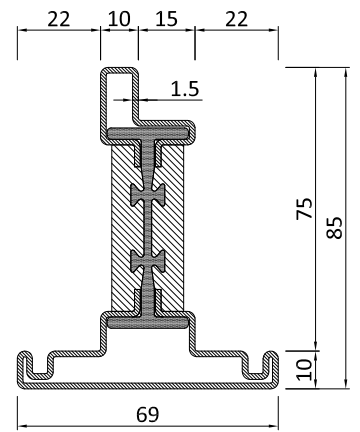

PR1312

Profilo / Profile n°	P Kg/m		A m ² /m	Jx cm ⁴	Jy cm ⁴	L m
	ZN / I - CT	OT				
PR1122	5,72	6,05	0,38	34,15	35,22	6
PR1123	5,73	6,05	0,38	38,86	31,70	6
PR1127	5,10	5,37	0,38	35,30	36,5	3
PR1301	3,81	4,03	0,28	27,35	6,59	6
PR1302	4,43	4,70	0,33	30,61	14,14	6

Profilo / Profile n°	P Kg/m		A m ² /m	Jx cm ⁴	Jy cm ⁴	L m
	ZN / I - CT	OT				
PR1303	4,43	4,71	0,33	35,07	12,71	6
PR1305	5,05	5,38	0,38	39,27	18,76	6
PR1311	3,79	4,02	0,27	25,15	6,56	6
PR1312	4,41	4,69	0,33	28,20	13,83	6

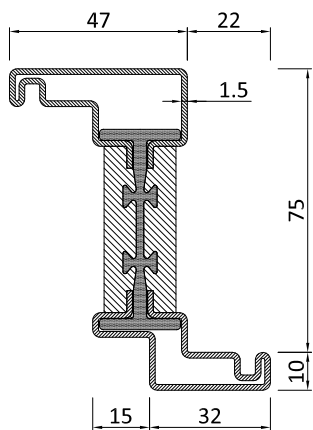

PR1313

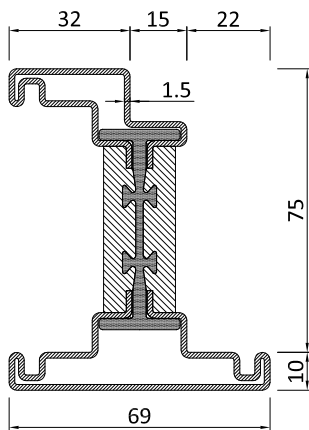

PR1315

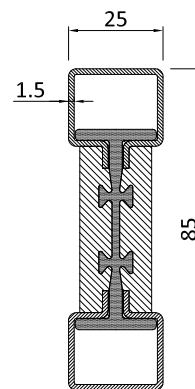

PR1320

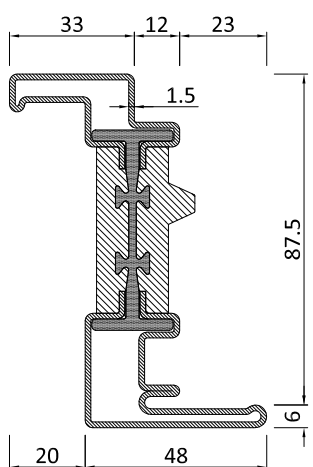

PR1333

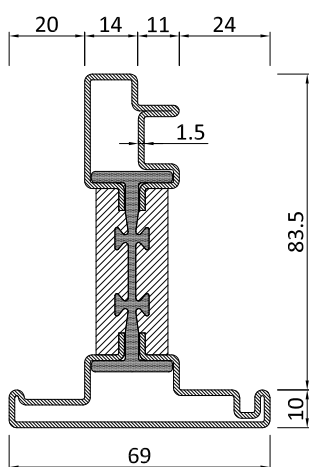

PR1924

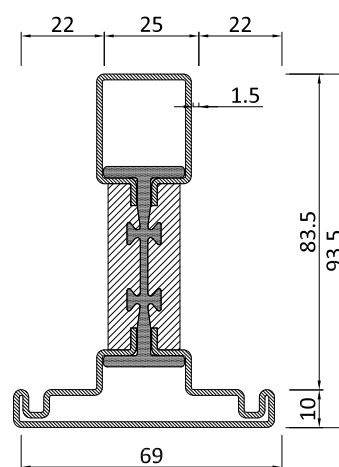

PR1902

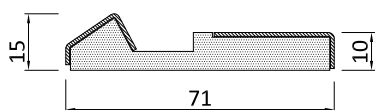

PR1130

Profilo / Profile n°	P Kg/m		A m ² /m	Jx cm ⁴	Jy cm ⁴	L m
	ZN / I - CT	OT				
PR1313	4,42	4,70	0,33	33,50	12,21	6
PR1315	5,04	5,37	0,38	38,20	18,60	6
PR1320	3,18	3,35	0,23	21,80	2,16	6
PR1333	4,86	5,16	0,38	42,97	9,86	6
PR1924	4,75	5,05	0,36	37,56	13,34	6

Profilo / Profile n°	P Kg/m		A m ² /m	Jx cm ⁴	Jy cm ⁴	L m
	ZN / I - CT	OT				
PR1902	4,64	4,93	0,35	34,95	14,14	3
PR1130	1,19	1,25	0,16			3

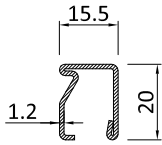

PR2007

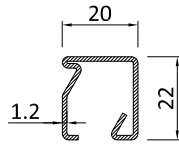

PR1007

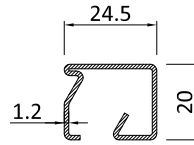

PR2008

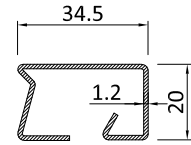

PR2009

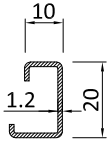

PR2015

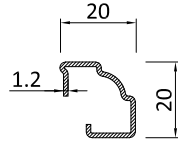

PR2028

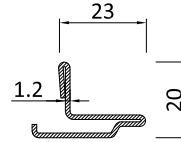

PR2038

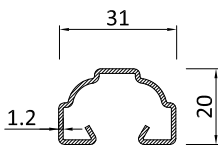

PR2030

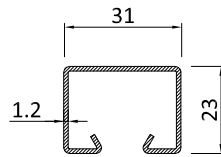

PR2031

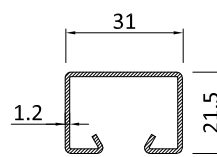

PR2032

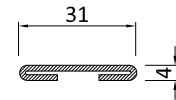

PR2034

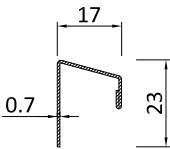

PR2027

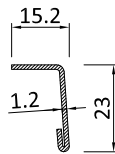

PR1129

MATERIALE | MATERIAL

PR ____ ZN acciaio zincato | *galvanized steel*

PR ____ CZ acciaio corten grezzo | *untreated corteen steel*

PR ____ ST acciaio inox satinato | *satined stainless steel*

PR ____ SB acciaio inox scotch brite | *scotch brite stainless steel*

PR ____ L3 acciaio inox lucido | *polished stainless steel*

PR ____ BR ottone grezzo | *untreated brass*

Profilo / Profile n°	P Kg/m		A m ² /m	Jx cm ⁴	Jy cm ⁴	L m
	ZN / I - CT	OT				
PR2007	0,60	0,65	0,06			6
PR1007	0,75	0,81	0,08			6
PR2008	0,79	0,86	0,09			6
PR2009	0,96	1,04	0,12			6
PR2015	0,44	0,48	0,05			6
PR2028	0,53	0,57	0,06			6
PR2038	0,72	0,78	0,08			6
PR2030	0,79	0,85	0,09			6
PR2031	0,93	1,00	0,1			4
PR2032	0,89	0,97	0,1			4

Profilo / Profile n°	P Kg/m		A m ² /m	Jx cm ⁴	Jy cm ⁴	L m
	ZN / I - CT	OT				
PR2034	0,60	0,65	0,05			4
PR2027	0,28	0,31	0,05			3
PR1129	0,38	0,42	0,04			3



AC1014.xx

Accessorio inversione battuta per porte
PR1112-PR1113

n.2 pz. per ogni angolo

*Reverse closure kit for doors
PR1112-PR1113*

n. 2 pieces for each corner



AC1037.xx

Cerniera a stilo ad avvitare con viti e rinforzi per porta
Peso massimo anta: 250 kg

*Hinge to be screwed with screws and strengtheners for door
Maximum leaf weight: 250 kg*

AISI 316

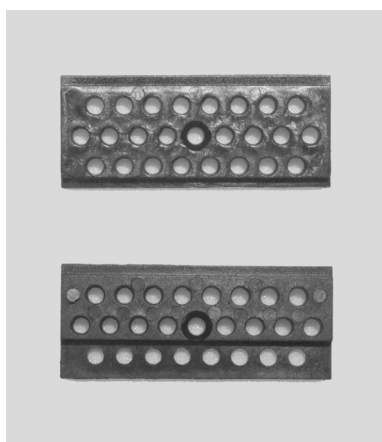

AC1020XL

Supporto per spessore vetro
Vetro superiore a 42 mm

*Glass spacer
Glass over 42 mm*

AC1020XS

Supporto per spessore vetro
Vetro fino a 42 mm

*Glass spacer
Glass up to 42 mm*

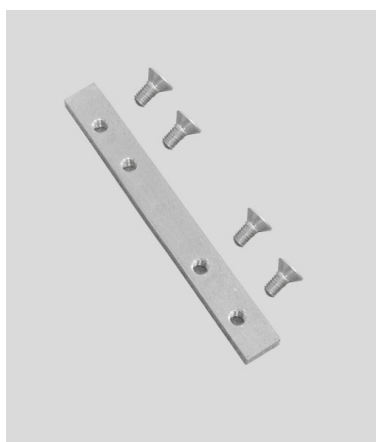

AC1037R

Rinforzo cerniera AC1037 su profili ridotti

Reinforcement for hinge AC1037 on reduced profiles



AC1033.xx

Cerniera a stilo ad avvitare con viti e rinforzi per porta
Peso massimo anta: 160 kg

*Screw-on hinge with screws and strengtheners for door
Maximum leaf weight: 160 kg*

AISI 304

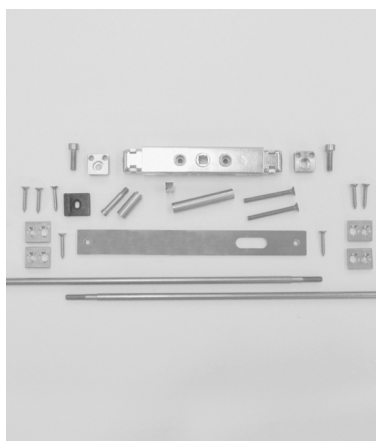

AC1039

Kit cremonese per chiusura orizzontale su sporgere

Cremonese bolt set for horizontal awning closing

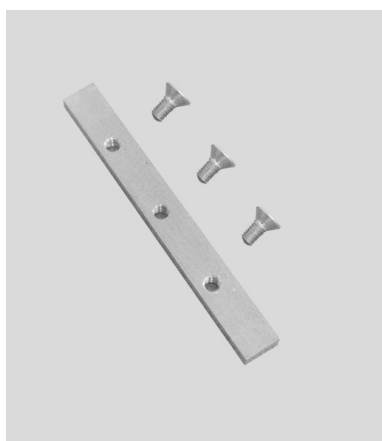

AC1033R

Rinforzo cerniera AC1033 su profili ridotti

Reinforcement for hinge AC1033 on reduced profiles



AC1040

Kit chiusura porte seconda anta
Acciaio inox

*Second leaf door closing kit
Stainless steel*

**AC1046**

Coppia compassi apertura a sporgere
Acciaio inox
Peso massimo anta: 75 kg

*Pair of side arms for awning opening
Stainless steel
Maximum leaf weight: 75 kg*

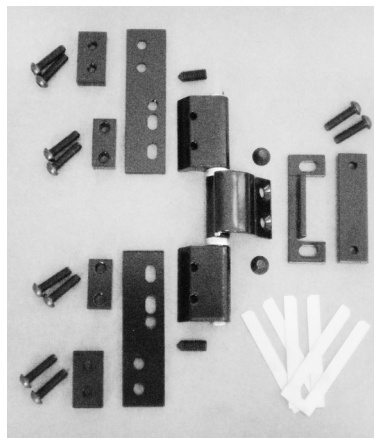
**AC1068.NE**

Cerniera a scomparsa per porta
Peso massimo anta: 180 kg
Massima apertura: 96°

*Concealed hinge for door
Maximum leaf weight: 180 kg
Maximum opening: 96°*

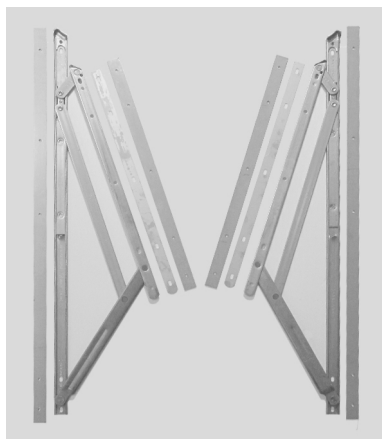
**AC1046M**

Coppia compassi apertura a sporgere
Acciaio inox
Peso massimo anta: 120 kg

*Pair of side arms for awning opening
Stainless steel
Maximum leaf weight: 120 kg*

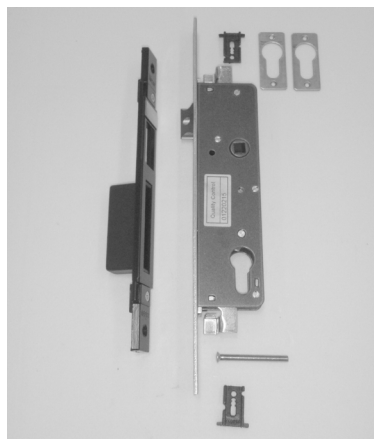
**AC1070**

Serratura con scrocco e catenaccio

Lock with spring latch and bolt

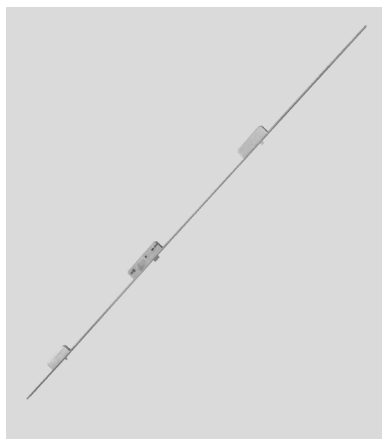
**AC1065W.D-S**

Serratura multipunto
Altezza anta da 2000 a 2300 mm

*Multipoint lock
Leaf height from 2000 to 2300 mm*

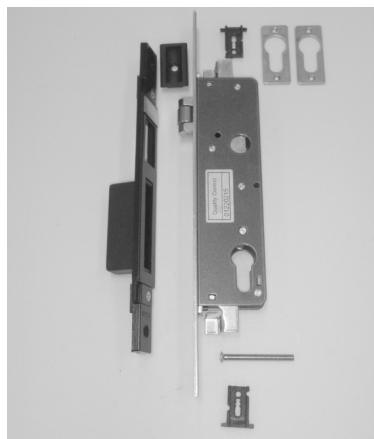
**AC1071**

Serratura con rullo e catenaccio

Lock with roller and bolt

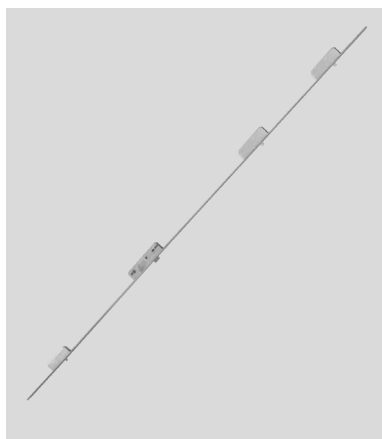
**AC 1067W.D-S**

Serratura multipunto
Altezza anta oltre 2900 mm

*Multipoint lock
Leaf height over 2900 mm*

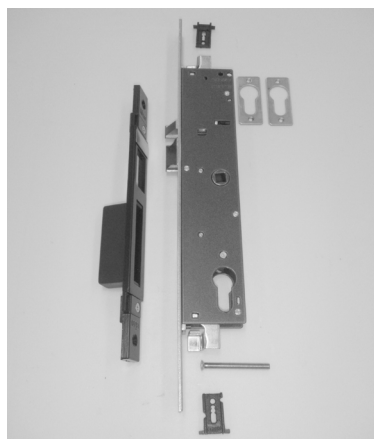
**AC1072**

Elettroserratura

Electric lock



AC1075

Deviatore per triplice chiusura

Deviator for three-point lock



AC1219.CZ

Scarico acqua per aperture interne in acciaio corten grezzo

Metal drip for inward openings in untreated corten steel



AC1080I

Rostro di sicurezza in acciaio inox
Completo di viti e rinforzi

*Stainless steel security pin
With screws and strengtheners*



AC1219.NE

Scarico acqua per aperture interne in plastica nera

Black plastic drip for inward openings

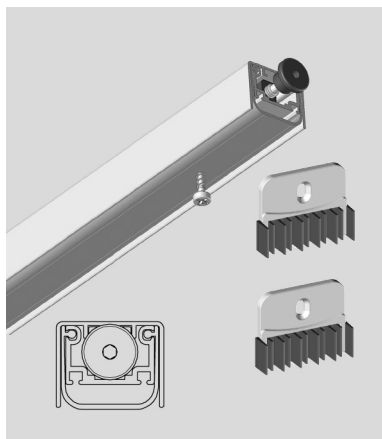

AC1081.x

Paraspiffero automatico a ghigliottina

Guillotine type draught excluder

Dimensioni anta | *Leaf dimension*

AC1081.A: 615 → 730 mm

AC1081.B: 715 → 830 mm

AC1081.C: 815 → 930 mm

AC1081.D: 915 → 1030 mm

AC1081.E: 1015 → 1130 mm

AC1081.F: 1115 → 1230 mm

AC1081.G: 1215 → 1330 mm

AC1081.H: 1315 → 1430 mm

AC1081.I: 1415 → 1530 mm



AC1219Y.xx

Scarico acqua per aperture interne in acciaio inox

Stainless steel drip for inward openings

AC1219Y.IZ inox verniciabile | *paintable stainless steel*
AC1219Y.SB inox scotch brite | *scotch brite st. steel*
AC1219Y.L3 inox lucido | *polished stainless steel*
AC1219Y.IB inox brunito | *burnished stainless steel*

AISI 316

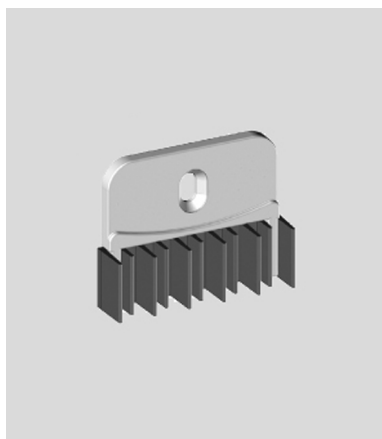

AC1081T

Accessorio di battuta

Stop accessory



AC1221.xx

Cerniera in acciaio inox a tre ali ad avvitare per vasistas
Peso massimo anta: 70-100 kg

*Stainless steel hinge to be screwed for bottom-hung window
Maximum leaf weight: 70-100 kg*

AC1221.SB inox scotch brite | *scotch brite st. steel*
AC1221.L3 inox lucido | *polished stainless steel*
AC1221.IB inox brunito | *burnished stainless steel*

AISI 316

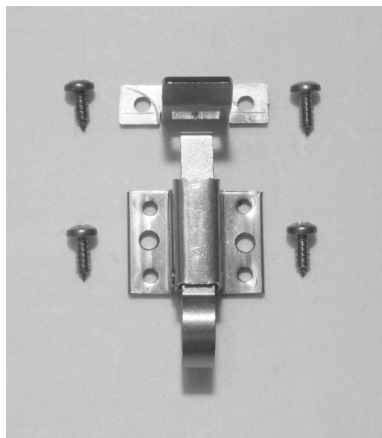

AC1223I

Cricchetto ed incontro da avvitare in acciaio inox, per vasistas

Screw-in latch and plate in stainless steel, for bottom-hung windows



AC1355.xx

Kit inversione battuta finestra A/R a due ante - nodo ZTZ

Reverse closing 2nd-leaf Tilt&Turn window - ZTZ profiles

AC1355.ZN acciaio zincato | galvanized steel
AC1355.CZ acciaio corten | corten steel
AC1355.IZ acciaio inox | stainless steel
AC1355.IB inox brunito | burnished stainless steel



AC1231S

Cricchetto ed incontro da avvitare in nylon nero, per vasistas

Screw-in latch and plate in black nylon, for bottom-hung windows



AC1356

Meccanismo DK esterno per maniglie "Vitruvio"

External tilt and turn mechanism for "Vitruvio" handles



AC1235

Coppia limitatori per apertura a vasistas
H min = 360 mm
Peso massimo anta: 70 kg

*Friction stays for bottom-hung windows
H min = 360 mm
Maximum leaf weight: 70 kg*



AC1714.xx

Kit inversione battuta per finestra a due ante con fondini a saldare e in gomma - nodo TZ

Reverse closure kit for 2-leaf window weld-on fitting and rubber fitting - TZ profiles

AC1714.ZN acciaio zincato | galvanized steel
AC1714.CZ acciaio corten | corten steel
AC1714.IZ acciaio inox | stainless steel
AC1714.BR ottone naturale | natural brass



AC1237.xx

Cerniera a stilo ad avvitare con viti e rinforzi per finestra
Peso massimo anta: 180 kg

*Hinge to be screwed with screws and strengtheners for window
Maximum leaf weight: 180 kg*

AC1237.IZ inox verniciabile | paintable stainless steel
AC1237.SB inox scotch brite | scotch brite st. steel
AC1237.L3 inox lucido | polished stainless steel
AC1237.IB inox brunito | burnished stainless steel

AISI 304

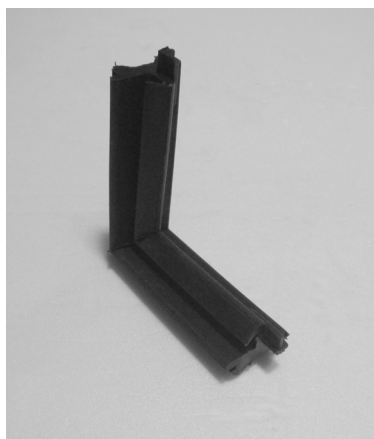

AC1716G

Guarnizione d'angolo vulcanizzata per GE1701

Vulcanised corner gasket for GE1701

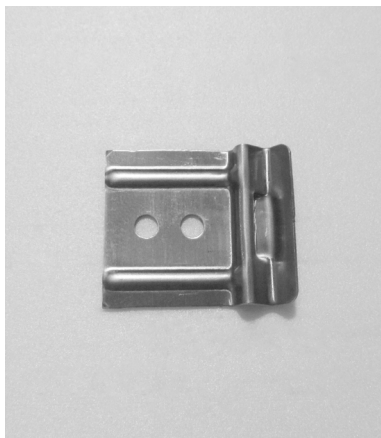
**AC2608**

Clips per fissaggio fermavetri
PR2015 - PR2028 - PR2038

*Clips for glazing bead
PR2015 - PR2028 - PR2038*

**AC5056**

Maniglia DK per cremonese in
acciaio inox scotch brite per
PR1333
Completa di viti

*DK handle for cremone bolt in
scotch-brite stainless steel for
PR1333
With fixing screws*

**AC2632.C**

Cerniera registrabile a due ali in
acciaio zincato a saldare | Ø 16
Peso massimo anta: 80 kg

*Adjustable weld-on hinge in
galvanised steel | Ø 16
Maximum leaf weight: 80 kg*

**AC6023**

Cerniera registrabile a due ali in
acciaio zincato a saldare | Ø 20
Peso massimo anta: 200 kg

*Adjustable weld-on hinge in
galvanised steel | Ø 20
Maximum leaf weight: 200 kg*

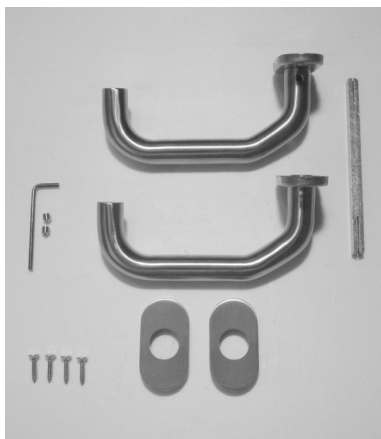
**AC5002.SB**

Coppia di maniglie per porta in
acciaio inox completa di viti

*Pair of stainless steel door
handles with screws*

**AG1224**

Cerniera a tre ali ad avvitare per
vasistas
Peso massimo anta: 70-100 kg

*Screw-on hinge for bottom-hung
window
Maximum leaf weight: 70-100 kg*

**AC5037**

Maniglia con incontro in lega
colore nero per apertura a
sporgere
Completa di viti di fissaggio

*Handle with black alloy plate for
projecting opening
With fixing screws*

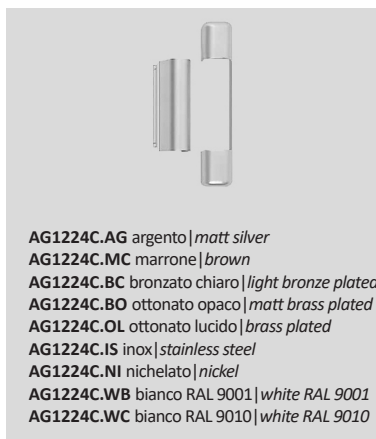
**AG1224C.xx**

Kit copertine in plastica per
cerniere AG1224

Plastic cover for hinges AG1224

AG1224C.AG argento | matt silver
AG1224C.MC marrone | brown
AG1224C.BC bronzato chiaro | light bronze plated
AG1224C.BO ottonato opaco | matt brass plated
AG1224C.OL ottonato lucido | brass plated
AG1224C.IS inox | stainless steel
AG1224C.NI nichelato | nickel
AG1224C.WB bianco RAL 9001 | white RAL 9001
AG1224C.WC bianco RAL 9010 | white RAL 9010

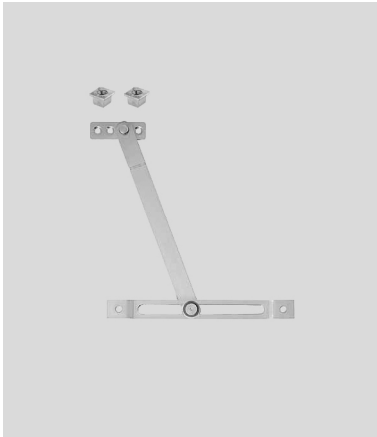
**AG1385**

Limitatore di apertura frizionato
per meccanismi A/R a vista
Solo per meccanismi EASY

*Friction stay for tilt-turn
mechanism, visible hinges
Only for EASY mechanism*

**AG1386**

Limitatore di apertura frizionato
per meccanismi A/R a scomparsa
Solo per meccanismi EASY

*Friction stay for tilt-turn
mechanism, concealed hinges
Only for EASY mechanism*

**AG6530**

Limitatore di corsa per
meccanismi A/R

*Opening limiter on tilt&turn
mechanism*

**CV5001.**

Vite per boccia fermavetri

Screw for glazing bead bushing

TPS 4.2x16 mm

CV5012.

Boccia per fermavetri

Bushing for glazing bead

CV5001 acciaio zincato | galvanized steel
CV5001I acciaio inox | stainless steel

CV5012 acciaio zincato | galvanized steel
CV5012I acciaio inox | stainless steel

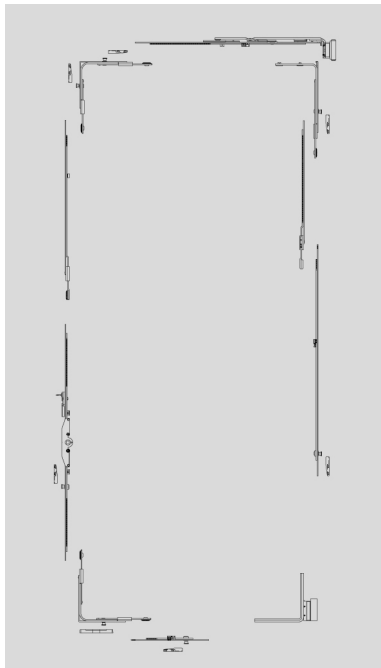

AGE271.xx

Meccanismo A/R prima anta Dx cerniere a vista

First leaf RH tilt-turn mechanism with visible hinges

EASY

AGE272.xx

Meccanismo A/R prima anta Sx cerniere a vista

First leaf LH tilt-turn mechanism with visible hinges

EASY

altezza - height

	661 860	861 1000	1001 1200	1201 1400	1401 1600	1601 1800	1801 2000	2001 2200	2201 2400	
	A1	B1	C1	D1	E1	F1	G1	H1	I1	
larghezza width	801-1000	-	B2	C2	D2	E2	F2	G2	H2	I2
	1001-1200	-	-	C3	D3	E3	F3	G3	H3	I3
	1201-1400	-	-	-	D4	E4	F4	G4	H4	I4
H maniglia handle	1/2	1/2	500	500	500	500	1050	1050	1050	

Limiti dimensionali | Limits

Peso massimo anta | *Maximum leaf weight: 150 kg*

misure cava ferramenta - H>L | *hardware measure - H>W*

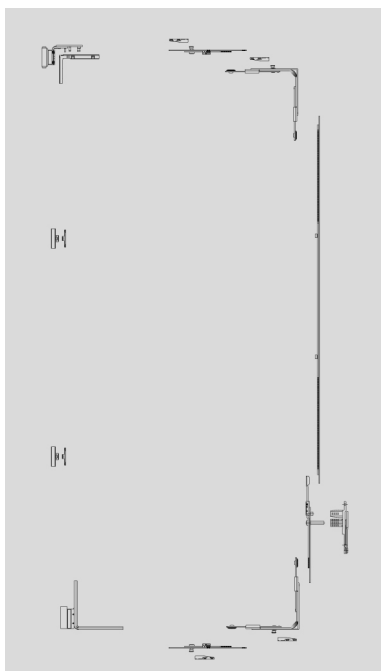

AGE275.xx

Meccanismo A/R seconda anta Dx cerniere a vista - Nodo ZTZ

Second leaf RH tilt-turn mechanism with visible hinges - ZTZ profiles

EASY

AGE276.xx

Meccanismo A/R seconda anta Sx cerniere a vista - Nodo ZTZ

Second leaf LH tilt-turn mechanism with visible hinges - ZTZ profiles

EASY

altezza - height

	661 860	861 1000	1001 1200	1201 1400	1401 1600	1601 1800	1801 2000	2001 2200	2201 2400	
	A1	B1	C1	D1	E1	F1	G1	H1	I1	
larghezza width	801-1000	-	B2	C2	D2	E2	F2	G2	H2	I2
	1001-1200	-	-	C3	D3	E3	F3	G3	H3	I3
	1201-1400	-	-	-	D4	E4	F4	G4	H4	I4

Limiti dimensionali | Limits

Peso massimo anta | *Maximum leaf weight: 150 kg*

misure cava ferramenta - H>L | *hardware measure - H>W*

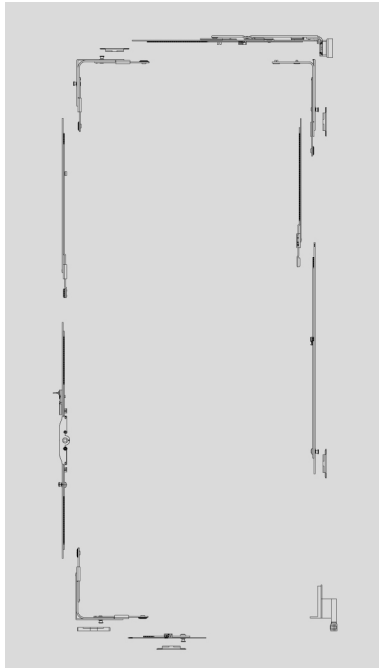

AG1291.xx

Meccanismo A/R prima anta Dx cerniere a vista in acciaio inox
First leaf RH tilt-turn mechanism with visible stainless steel hinges
RC2 (no su profili in ottone | *not on brass profiles*)

AG1292.xx

Meccanismo A/R prima anta Sx cerniere a vista in acciaio inox
First leaf LH tilt-turn mechanism with visible stainless steel hinges
RC2 (no su profili in ottone | *not on brass profiles*)
 altezza - height

	661 860	861 1000	1001 1200	1201 1400	1401 1600	1601 1800	1801 2000	2001 2200	2201 2400	
	A1	B1	C1	D1	E1	F1	G1	H1	I1	
larghezza width	801-1000	-	B2	C2	D2	E2	F2	G2	H2	I2
	1001-1200	-	-	C3	D3	E3	F3	G3	H3	I3
	1201-1400	-	-	-	D4	E4	F4	G4	H4	I4
H maniglia handle	1/2	1/2	500	500	500	500	1050	1050	1050	

Limiti dimensionali | Limits

Peso massimo anta | *Maximum leaf weight: 130 kg*
 misure cava ferramenta - H>L | *hardware measure - H>W*

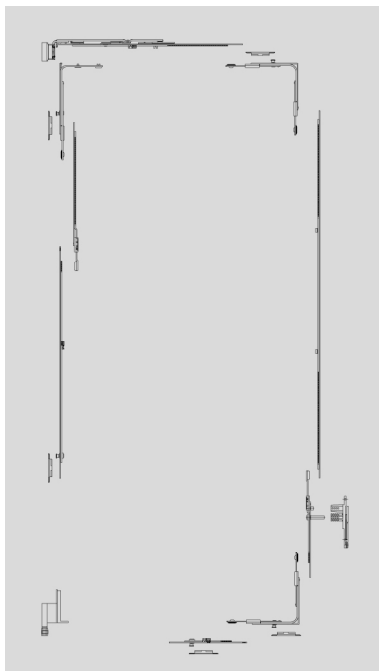

AG1295.xx

Meccanismo A/R seconda anta Dx cerniere a vista in acciaio inox - Nodo ZTZ
Second leaf RH tilt-turn mechanism with visible stainless steel hinges - ZTZ profiles
RC2 (no su profili in ottone | *not on brass profiles*)

AG1296.xx

Meccanismo A/R seconda anta Sx cerniere a vista in acciaio inox - Nodo ZTZ
Second leaf LH tilt-turn mechanism with visible stainless steel hinges - ZTZ profiles
RC2 (no su profili in ottone | *not on brass profiles*)

	altezza - height									
	661 860	861 1000	1001 1200	1201 1400	1401 1600	1601 1800	1801 2000	2001 2200	2201 2400	
	A1	B1	C1	D1	E1	F1	G1	H1	I1	
larghezza width	801-1000	-	B2	C2	D2	E2	F2	G2	H2	I2
	1001-1200	-	-	C3	D3	E3	F3	G3	H3	I3
	1201-1400	-	-	-	D4	E4	F4	G4	H4	I4

Limiti dimensionali | Limits

Peso massimo anta | *Maximum leaf weight: 130 kg*
 misure cava ferramenta - H>L | *hardware measure - H>W*

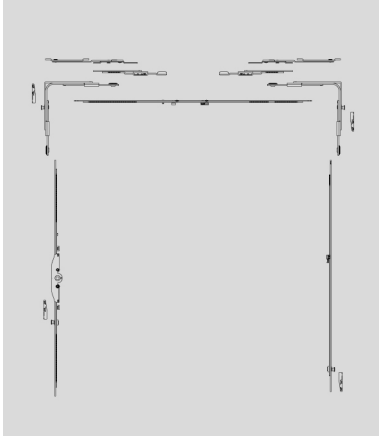

AG1264.xx

Meccanismo vasistas con cremonese su montante laterale

Bottom-hung window mechanism with lateral cremonese bolt set
EASY

altezza - height

	560	661	861	1201	
	660	860	1200	1600	
	645-910	A1	B1	C1	D1
larghezza	911-1110	A2	B2	C2	D2
width	1111-1470	A3	B3	C3	D3
	1471-1860	A4	B4	C4	D4

Limiti dimensionali | Limits

Peso massimo anta | *Maximum leaf weight: 100 kg* 3 cerniere | 3 hinges

Peso massimo anta | *Maximum leaf weight: 70 kg* 2 cerniere | 2 hinges

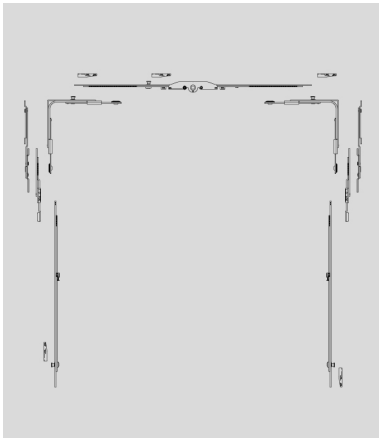

AG1274.xx

Meccanismo vasistas con cremonese su traverso superiore

Bottom-hung window mechanism with top cremonese bolt set
EASY

altezza - height

	350	661	861	1201	
	660	860	1200	1400	
	560-660	A1	B1	C1	D1
larghezza	661-860	A2	B2	C2	D2
width	861-1200	A3	B3	C3	D3
	1201-1600	A4	B4	C4	D4

Limiti dimensionali | Limits

Peso massimo anta | *Maximum leaf weight: 100 kg* 3 cerniere | 3 hinges

Peso massimo anta | *Maximum leaf weight: 70 kg* 2 cerniere | 2 hinges

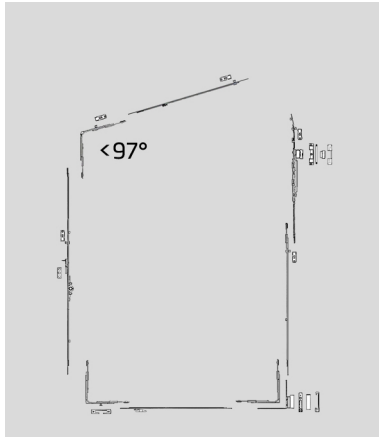
**AG1273.xx**

Meccanismo A/R trapezoidale ad una o due ante con cerniere a vista
(specificare all'ordine misure cava ferramenta e mano di apertura)

*Tilt-turn mechanism with visible hinges for trapezoidal windows
(Specify hardware slot size and the opening)*

EASY

Limiti dimensionali | Limits

Peso massimo anta | *Maximum leaf weight: 80 kg*

Larghezza massima | *Maximum width: 1200 mm*

Altezza massima | *Maximum height: 2400 mm*

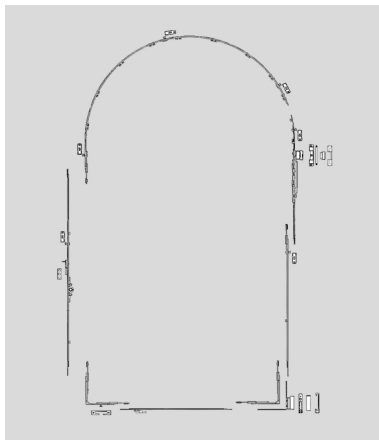
**AG1278.xx**

Meccanismo A/R curvo ad una o due ante con cerniere a vista
(specificare all'ordine misure cava ferramenta e mano di apertura)

*Tilt-turn mechanism with visible hinges for arched windows
(Specify hardware slot size and the opening)*

EASY

Limiti dimensionali | Limits

Peso massimo anta | *Maximum leaf weight: 80 kg*

Larghezza massima | *Maximum width: 1200 mm*

Altezza massima arco reale | *Maximum height arch: 1900 mm*

Altezza massima arco ribassato | *Maximum height segmental arch: 2400 mm*

**AG1278C.xx**

Kit copertine destre in plastica
per kit A/R AG1273-8

*Plastic right-cover kit for
tilt&turn for kit AG1273-8*

AG1279C.xx

Kit copertine sinistre in plastica
per kit A/R AG1273-8

*Plastic left-cover kit for tilt&turn
for kit AG1273-8*

AG127-C.AG argento | *matt silver*
AG127-C.MC marrone | *brown*
AG127-C.BC bronzato chiaro | *light bronze plated*
AG127-C.BO ottonato opaco | *matt brass plated*
AG127-C.OL ottonato lucido | *brass plated*
AG127-C.IS inox | *stainless steel*
AG127-C.NI nichelato | *nickel*
AG127-C.WB bianco RAL 9001 | *white RAL 9001*
AG127-C.WC bianco RAL 9010 | *white RAL 9010*

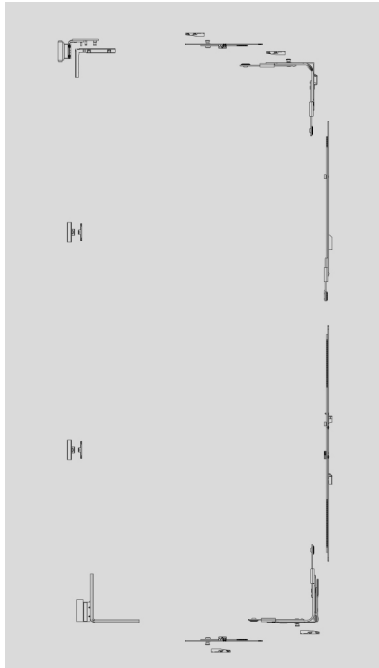

AGE775.xx

Meccanismo A/R seconda anta Dx cerniere a vista - Nodo TZ

Second leaf RH tilt-turn mechanism with visible hinges - TZ profiles

EASY

AGE776.xx

Meccanismo A/R seconda anta Sx cerniere a vista - Nodo TZ

Second leaf LH tilt-turn mechanism with visible hinges - TZ profiles

EASY

		altezza - height								
		661	861	1001	1201	1401	1601	1801	2001	2201
		860	1000	1200	1400	1600	1800	2000	2200	2400
	601-800	A1	B1	C1	D1	E1	F1	G1	H1	I1
larghezza width	801-1000	-	B2	C2	D2	E2	F2	G2	H2	I2
	1001-1200	-	-	C3	D3	E3	F3	G3	H3	I3
	1201-1400	-	-	-	D4	E4	F4	G4	H4	I4

Limiti dimensionali | Limits

Peso massimo anta | *Maximum leaf weight: 150 kg*

misure cava ferramenta - H>L | *hardware measure - H>W*



AG1271C.xx

Kit copertine destre in plastica per kit A/R AGE271-5

Plastic right-cover kit for tilt&turn for kit AGE271-5

AG1272C.xx

Kit copertine sinistre in plastica per kit A/R AGE272-6

Plastic left-cover kit for tilt&turn for kit AGE272-6

- AG127-C.AG argento | *matt silver*
- AG127-C.MC marrone | *brown*
- AG127-C.BC bronzato chiaro | *light bronze plated*
- AG127-C.BO ottonato opaco | *matt brass plated*
- AG127-C.OL ottonato lucido | *brass plated*
- AG127-C.IS inox | *stainless steel*
- AG127-C.NI nichelato | *nickel*
- AG127-C.WB bianco RAL 9001 | *white RAL 9001*
- AG127-C.WC bianco RAL 9010 | *white RAL 9010*

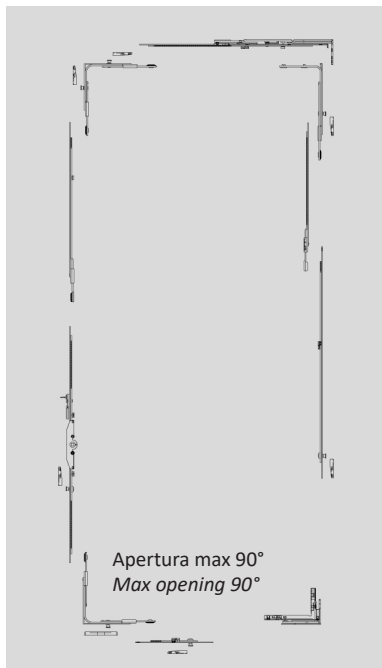

AGE281.xx

Meccanismo A/R prima anta Dx cerniere a scomparsa

First leaf RH tilt-turn mechanism with concealed hinges

EASY

AGE282.xx

Meccanismo A/R prima anta Sx cerniere a scomparsa

First leaf LH tilt-turn mechanism with concealed hinges

EASY

altezza - height

	661 860	861 1000	1001 1200	1201 1400	1401 1600	1601 1800	1801 2000	2001 2200	2201 2400	
	601-800	A1	B1	C1	D1	E1	F1	G1	H1	I1
larghezza width	801-1000	-	B2	C2	D2	E2	F2	G2	H2	I2
	1001-1200	-	-	C3	D3	E3	F3	G3	H3	I3
	1201-1400	-	-	-	D4	E4	F4	G4	H4	I4
H maniglia handle	1/2	1/2	500	500	500	500	1050	1050	1050	

Limiti dimensionali | Limits

Peso massimo anta | *Maximum leaf weight: 130 kg*

misure cava ferramenta - H>L | *hardware measure - H>W*

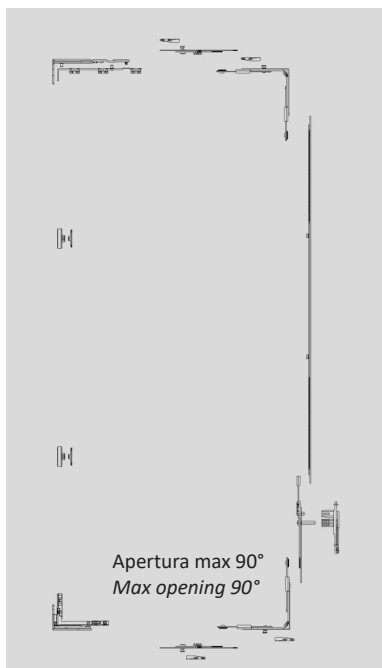

AGE285.xx

Meccanismo A/R seconda anta Dx cerniere a scomparsa - Nodo ZTZ

Second leaf RH tilt-turn mechanism with concealed hinges - ZTZ profiles

EASY

AGE286.xx

Meccanismo A/R seconda anta Sx cerniere a scomparsa - Nodo ZTZ

Second leaf LH tilt-turn mechanism with concealed hinges - ZTZ profiles

EASY

altezza - height

	661 860	861 1000	1001 1200	1201 1400	1401 1600	1601 1800	1801 2000	2001 2200	2201 2400	
	601-800	A1	B1	C1	D1	E1	F1	G1	H1	I1
larghezza width	801-1000	-	B2	C2	D2	E2	F2	G2	H2	I2
	1001-1200	-	-	C3	D3	E3	F3	G3	H3	I3
	1201-1400	-	-	-	D4	E4	F4	G4	H4	I4

Limiti dimensionali | Limits

Peso massimo anta | *Maximum leaf weight: 130 kg*

misure cava ferramenta - H>L | *hardware measure - H>W*

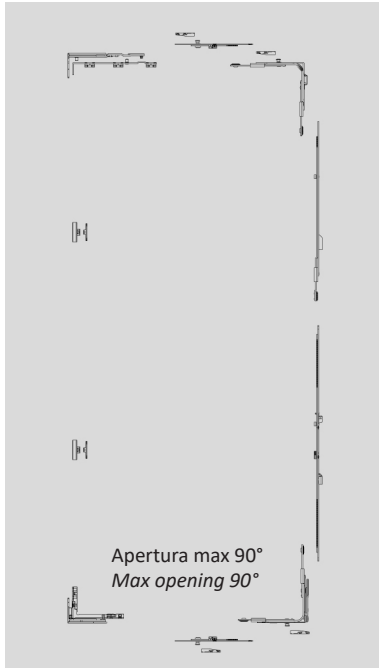

AGE785.xx

Meccanismo A/R seconda anta Dx cerniere a scomparsa - Nodo TZ

Second leaf RH tilt-turn mechanism with concealed hinges - TZ profiles

EASY

AGE786.xx

Meccanismo A/R seconda anta Sx cerniere a scomparsa - Nodo TZ

Second leaf LH tilt-turn mechanism with concealed hinges - TZ profiles

EASY

		altezza - height								
		661	861	1001	1201	1401	1601	1801	2001	2201
		860	1000	1200	1400	1600	1800	2000	2200	2400
larghezza width	601-800	A1	B1	C1	D1	E1	F1	G1	H1	I1
	801-1000	-	B2	C2	D2	E2	F2	G2	H2	I2
	1001-1200	-	-	C3	D3	E3	F3	G3	H3	I3
	1201-1400	-	-	-	D4	E4	F4	G4	H4	I4

Limiti dimensionali | Limits

Peso massimo anta | *Maximum leaf weight: 130 kg*

misure cava ferramenta - H>L | *hardware measure - H>W*

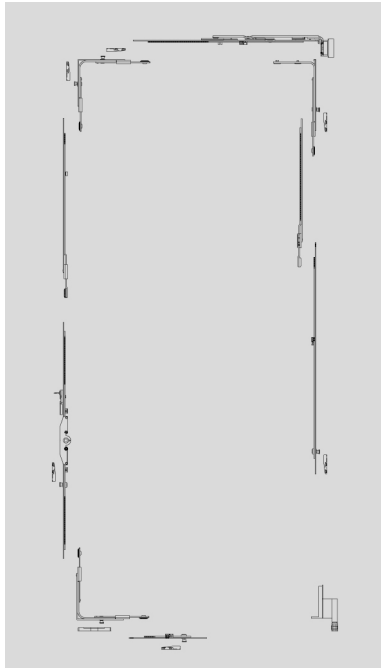

AGE291.xx

Meccanismo A/R prima anta Dx cerniere a vista in acciaio inox
First leaf RH tilt-turn mechanism with visible stainless steel hinges

EASY

AGE292.xx

Meccanismo A/R prima anta Sx cerniere a vista in acciaio inox
First leaf LH tilt-turn mechanism with visible stainless steel hinges

EASY

altezza - height

	661 860	861 1000	1001 1200	1201 1400	1401 1600	1601 1800	1801 2000	2001 2200	2201 2400	
	A1	B1	C1	D1	E1	F1	G1	H1	I1	
larghezza width	801-1000	-	B2	C2	D2	E2	F2	G2	H2	I2
	1001-1200	-	-	C3	D3	E3	F3	G3	H3	I3
	1201-1400	-	-	-	D4	E4	F4	G4	H4	I4
H maniglia handle	1/2	1/2	500	500	500	500	1050	1050	1050	

Limiti dimensionali | Limits

Peso massimo anta | *Maximum leaf weight: 130 kg*
misure cava ferramenta - H>L | *hardware measure - H>W*

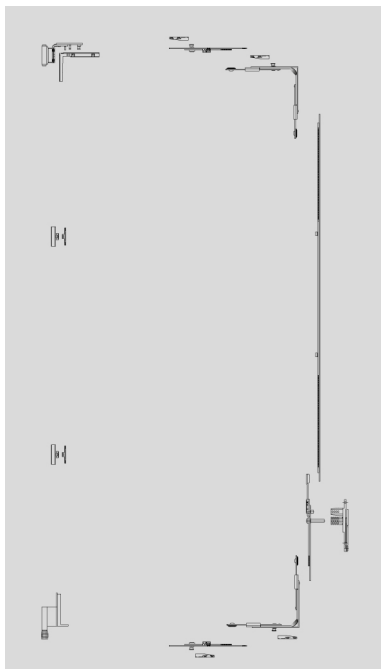

AGE295.xx

Meccanismo A/R seconda anta Dx cerniere a vista in acciaio inox - Nodo ZTZ
Second leaf RH tilt-turn mechanism with visible stainless steel hinges - ZTZ profiles

EASY

AGE296.xx

Meccanismo A/R seconda anta Sx cerniere a vista in acciaio inox - Nodo ZTZ
Second leaf LH tilt-turn mechanism with visible stainless steel hinges - ZTZ profiles

EASY

altezza - height

	661 860	861 1000	1001 1200	1201 1400	1401 1600	1601 1800	1801 2000	2001 2200	2201 2400	
	A1	B1	C1	D1	E1	F1	G1	H1	I1	
larghezza width	801-1000	-	B2	C2	D2	E2	F2	G2	H2	I2
	1001-1200	-	-	C3	D3	E3	F3	G3	H3	I3
	1201-1400	-	-	-	D4	E4	F4	G4	H4	I4

Limiti dimensionali | Limits

Peso massimo anta | *Maximum leaf weight: 130 kg*
misure cava ferramenta - H>L | *hardware measure - H>W*

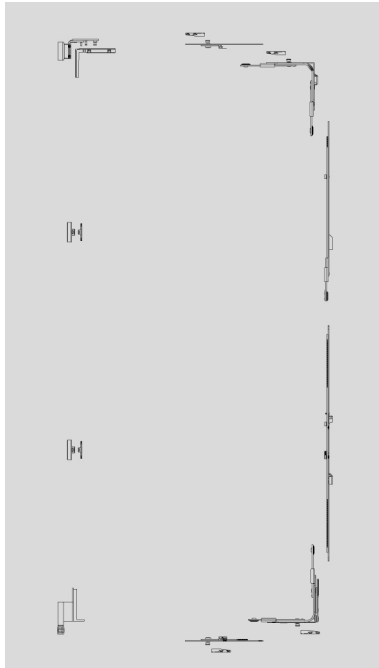

AGE795.xx

Meccanismo A/R seconda anta Dx cerniere a vista in acciaio inox - Nodo TZ

Second leaf RH tilt-turn mechanism with visible stainless steel hinges - TZ profiles

EASY

AGE796.xx

Meccanismo A/R seconda anta Sx cerniere a vista in acciaio inox - Nodo TZ

Second leaf LH tilt-turn mechanism with visible stainless steel hinges - TZ profiles

EASY

		altezza - height								
		661	861	1001	1201	1401	1601	1801	2001	2201
		860	1000	1200	1400	1600	1800	2000	2200	2400
	601-800	A1	B1	C1	D1	E1	F1	G1	H1	I1
larghezza width	801-1000	-	B2	C2	D2	E2	F2	G2	H2	I2
	1001-1200	-	-	C3	D3	E3	F3	G3	H3	I3
	1201-1400	-	-	-	D4	E4	F4	G4	H4	I4

Limiti dimensionali | Limits

Peso massimo anta | *Maximum leaf weight: 130 kg*

misure cava ferramenta - H>L | *hardware measure - H>W*

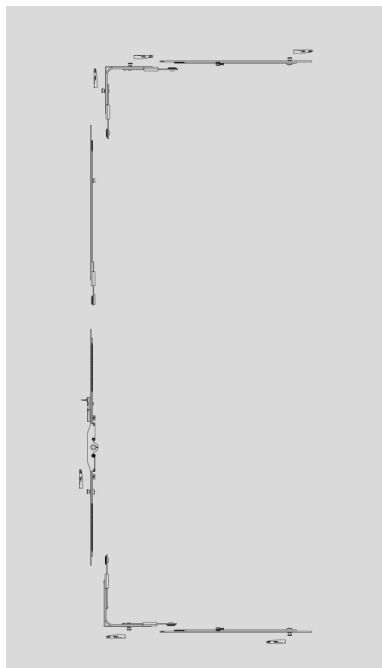

AGA271.xx

Meccanismo di chiusura anta principale Dx o Sx con telaio sui quattro lati, cerniere escluse

Master leaf RH or LH locking mechanism on four sides, hinges excluded

EASY

		altezza - height								
		661 860	861 1000	1001 1200	1201 1400	1401 1600	1601 1800	1801 2000	2001 2200	2201 2400
larghezza width	601-800	A1	B1	C1	D1	E1	F1	G1	H1	I1
	801-1000	-	B2	C2	D2	E2	F2	G2	H2	I2
	1001-1200	-	-	C3	D3	E3	F3	G3	H3	I3
	1201-1400	-	-	-	D4	E4	F4	G4	H4	I4
H maniglia handle		1/2	1/2	500	500	500	500	1050	1050	1050

Limiti dimensionali | Limits

misure cava ferramenta - H>L | hardware measure - H>W

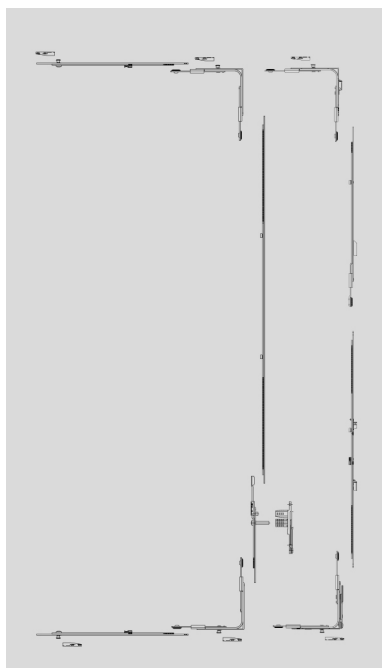

AGA275.xx

Meccanismo di chiusura seconda anta Dx o Sx con telaio sui quattro lati, cerniere escluse - nodo ZTZ

Second leaf leaf RH or LH locking mechanism on four sides, hinges excluded - ZTZ profiles

EASY

AGA775.xx

Meccanismo di chiusura seconda anta Dx o Sx con telaio sui quattro lati, cerniere escluse - nodo TZ

Second leaf leaf RH or LH locking mechanism on four sides, hinges excluded - TZ profiles

EASY

		altezza - height								
		661 860	861 1000	1001 1200	1201 1400	1401 1600	1601 1800	1801 2000	2001 2200	2201 2400
larghezza width	601-800	A1	B1	C1	D1	E1	F1	G1	H1	I1
	801-1000	-	B2	C2	D2	E2	F2	G2	H2	I2
	1001-1200	-	-	C3	D3	E3	F3	G3	H3	I3
	1201-1400	-	-	-	D4	E4	F4	G4	H4	I4

Limiti dimensionali | Limits

misure cava ferramenta - H>L | hardware measure - H>W



AG1271.xx

Meccanismo A/R prima anta Dx cerniere a vista

First leaf RH tilt-turn mechanism with visible hinges

RC2 (no su profili in ottone | not on brass profiles)

AG1272.xx

Meccanismo A/R prima anta Sx cerniere a vista

First leaf LH tilt-turn mechanism with visible hinges

RC2 (no su profili in ottone | not on brass profiles)
altezza - height

	661 860	861 1000	1001 1200	1201 1400	1401 1600	1601 1800	1801 2000	2001 2200	2201 2400	
	A1	B1	C1	D1	E1	F1	G1	H1	I1	
larghezza width	801-1000	-	B2	C2	D2	E2	F2	G2	H2	I2
	1001-1200	-	-	C3	D3	E3	F3	G3	H3	I3
	1201-1400	-	-	-	D4	E4	F4	G4	H4	I4
H maniglia handle	1/2	1/2	500	500	500	500	1050	1050	1050	

Limiti dimensionali | Limits

Peso massimo anta | Maximum leaf weight: 150 kg

misure cava ferramenta - H>L | hardware measure - H>W

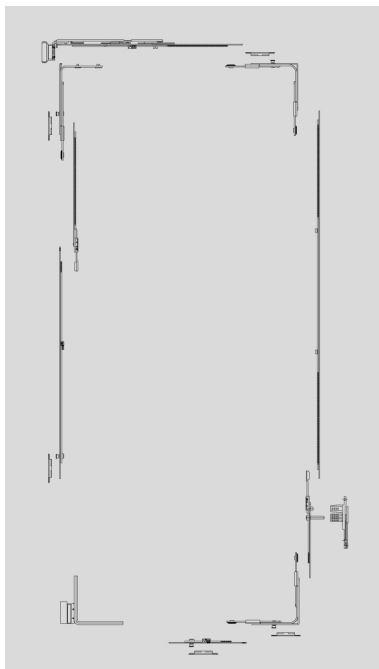

AG1275.xx

Meccanismo A/R seconda anta Dx cerniere a vista - Nodo ZTZ

Second leaf RH tilt-turn mechanism with visible hinges - ZTZ profiles

RC2 (no su profili in ottone | not on brass profiles)

AG1276.xx

Meccanismo A/R seconda anta Sx cerniere a vista - Nodo ZTZ

Second leaf LH tilt-turn mechanism with visible hinges - ZTZ profiles

RC2 (no su profili in ottone | not on brass profiles)

	altezza - height									
	661 860	861 1000	1001 1200	1201 1400	1401 1600	1601 1800	1801 2000	2001 2200	2201 2400	
	A1	B1	C1	D1	E1	F1	G1	H1	I1	
larghezza width	801-1000	-	B2	C2	D2	E2	F2	G2	H2	I2
	1001-1200	-	-	C3	D3	E3	F3	G3	H3	I3
	1201-1400	-	-	-	D4	E4	F4	G4	H4	I4

Limiti dimensionali | Limits

Peso massimo anta | Maximum leaf weight: 150 kg

misure cava ferramenta - H>L | hardware measure - H>W



AG 1271C.xx

Kit copertine destre in plastica per kit A/R AG1271-5

Plastic right-cover kit for tilt&turn for kit AG1271-5

AG1272C.xx

Kit copertine sinistre in plastica per kit A/R AG1272-6

Plastic left-cover kit for tilt&turn for kit AG1272-6

- AG127-C.AG argento | matt silver
- AG127-C.MC marrone | brown
- AG127-C.BC bronzato chiaro | light bronze plated
- AG127-C.BO ottonato opaco | matt brass plated
- AG127-C.OL ottonato lucido | brass plated
- AG127-C.IS inox | stainless steel
- AG127-C.NI nichelato | nickel
- AG127-C.WB bianco RAL 9001 | white RAL 9001
- AG127-C.WC bianco RAL 9010 | white RAL 9010

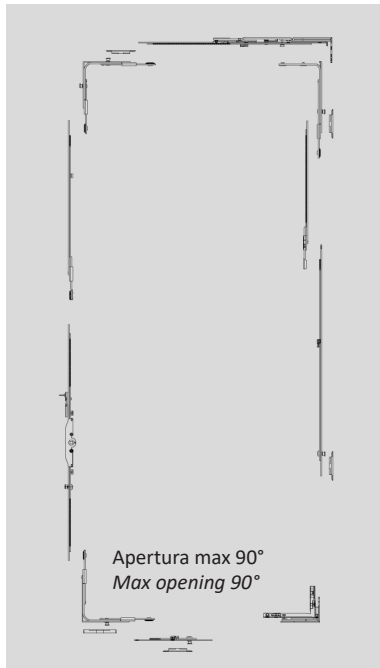

AG1281.xx

Meccanismo A/R prima anta Dx cerniere a scomparsa

First leaf RH tilt-turn mechanism with concealed hinges

RC2 (no su profili in ottone | not on brass profiles)

AG1282.xx

Meccanismo A/R prima anta Sx cerniere a scomparsa

First leaf LH tilt-turn mechanism with concealed hinges

RC2 (no su profili in ottone | not on brass profiles)
altezza - height

	661 860	861 1000	1001 1200	1201 1400	1401 1600	1601 1800	1801 2000	2001 2200	2201 2400	
	601-800	A1	B1	C1	D1	E1	F1	G1	H1	I1
larghezza width	801-1000	-	B2	C2	D2	E2	F2	G2	H2	I2
	1001-1200	-	-	C3	D3	E3	F3	G3	H3	I3
	1201-1400	-	-	-	D4	E4	F4	G4	H4	I4
H maniglia handle	1/2	1/2	500	500	500	500	1050	1050	1050	

Limiti dimensionali | Limits

Peso massimo anta | Maximum leaf weight: 130 kg

misure cava ferramenta - H>L | hardware measure - H>W

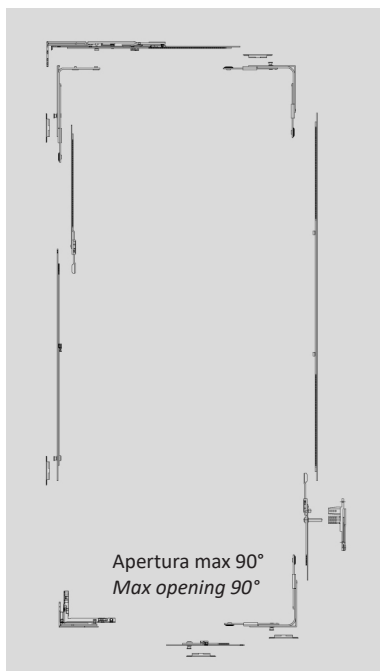

AG1285.xx

Meccanismo A/R seconda anta Dx cerniere a scomparsa - Nodo ZTZ

Second leaf RH tilt-turn mechanism with concealed hinges - ZTZ profiles

RC2 (no su profili in ottone | not on brass profiles)

AG1286.xx

Meccanismo A/R seconda anta Sx cerniere a scomparsa - Nodo ZTZ

Second leaf LH tilt-turn mechanism with concealed hinges - ZTZ profiles

RC2 (no su profili in ottone | not on brass profiles)

	altezza - height									
	661 860	861 1000	1001 1200	1201 1400	1401 1600	1601 1800	1801 2000	2001 2200	2201 2400	
	601-800	A1	B1	C1	D1	E1	F1	G1	H1	I1
larghezza width	801-1000	-	B2	C2	D2	E2	F2	G2	H2	I2
	1001-1200	-	-	C3	D3	E3	F3	G3	H3	I3
	1201-1400	-	-	-	D4	E4	F4	G4	H4	I4

Limiti dimensionali | Limits

Peso massimo anta | Maximum leaf weight: 130 kg

misure cava ferramenta - H>L | hardware measure - H>W

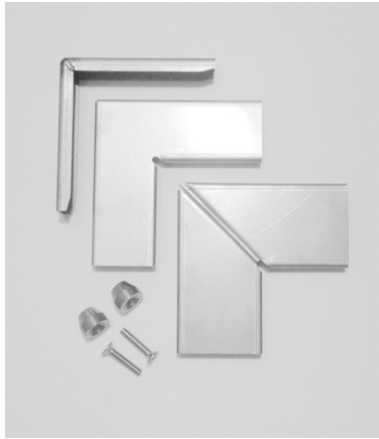

AC1001I

Kit per giunzione angolo
Acciaio inox

*Corner joint kit
Stainless steel*

PR1101



AC1005I

Kit per giunzione angolo
Acciaio inox

*Corner joint kit
Stainless steel*

PR1112



AC1002I

Kit per giunzione angolo
Acciaio inox

*Corner joint kit
Stainless steel*

PR1102



AC1006I

Kit per giunzione angolo
Acciaio inox

*Corner joint kit
Stainless steel*

PR1113 cassa | frame



AC1003I

Kit per giunzione angolo
Acciaio inox

*Corner joint kit
Stainless steel*

PR1103



AC1007I

Kit per giunzione angolo
Acciaio inox

*Corner joint kit
Stainless steel*

PR1113 anta | leaf



AC1004I

Kit per giunzione angolo
Acciaio inox

*Stainless steel
Corner joint kit
Stainless steel*

PR1111



AC1008I

Kit per giunzione angolo
Acciaio inox

*Stainless steel
Corner joint kit*

PR1112-PR1113



AC1009I

Kit per giunzione angolo
Acciaio inox

*Corner joint kit
Stainless steel
PR1105*

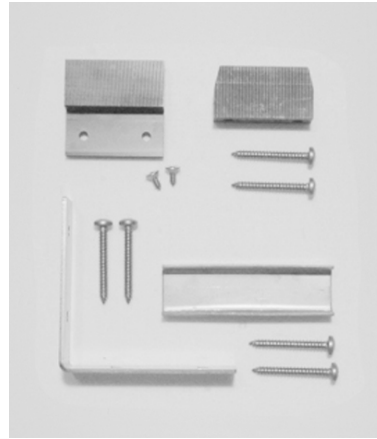

AC1023

Kit per giunzione 90° profili
maggiorati su giunto d'angolo

*Butt joint kit on corner section
for oversize profiles
Stainless steel*



AC1013I

Kit per giunzione angolo
Acciaio inox

*Corner joint kit
Stainless steel
PR1110*



AC1024ID

Kit per giunzione angolo destro
Acciaio inox

*Right corner joint kit
Stainless steel
PR1127-PR1112*

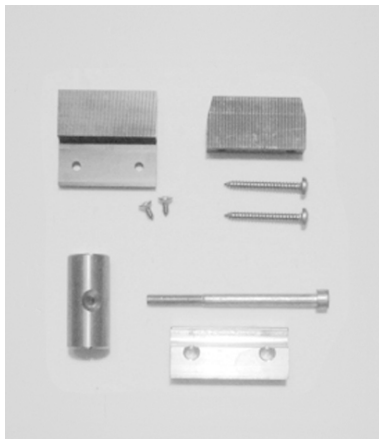

AC1021

Kit per giunzione 90°
Acciaio inox

*Butt joint kit
Stainless steel
PR1105
PR1101
PR1102*



AC1024IS

Kit per giunzione angolo sinistro
Acciaio inox

*Left corner joint kit
Stainless steel
PR1127-PR1112*

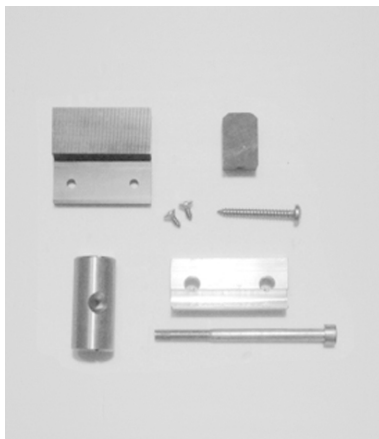

AC1022

Kit per giunzione 90°
Acciaio inox

*Butt joint kit
Stainless steel
PR1122*



AC1201I

Kit per giunzione angolo
Acciaio inox

*Corner joint kit
Stainless steel
PR1301*



AC1202I

Kit per giunzione angolo
Acciaio inox

*Corner joint kit
Stainless steel*

PR1302



AC1211I

Kit per giunzione 90°
Acciaio inox

*Butt joint kit
Stainless steel*

PR1302
1/2 - PR1301 | PR1305

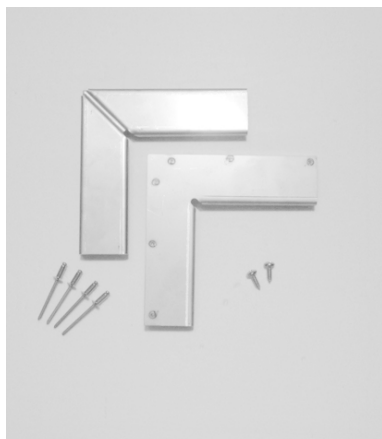

AC1203I

Kit per giunzione angolo
Acciaio inox

*Corner joint kit
Stainless steel*

PR1303



AC1211IA

Kit per giunzione 90° profili
ridotti su giunto d'angolo
Acciaio inox

*Butt joint kit on corner section
for reduced profiles
Stainless steel*



AC1207I

Kit per giunzione angolo
Acciaio inox

*Corner joint kit
Stainless steel*

PR1333



AC1708I

Kit per giunzione angolo
Acciaio inox

*Corner joint kit
Stainless steel*

PR1924-PR1333

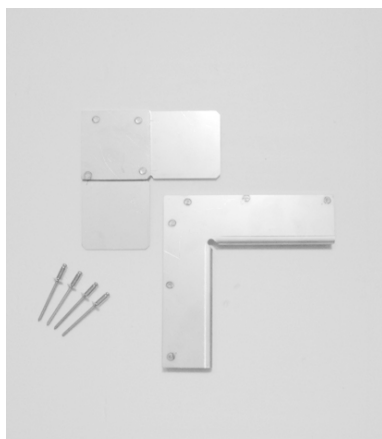

AC1209I

Kit per giunzione angolo
Acciaio inox

*Corner joint kit
Stainless steel*

PR1305



AC1730I

Kit per giunzione angolo
Acciaio inox

*Corner joint kit
Stainless steel*

PR1320

**AC1731I**

Kit per giunzione angolo
Acciaio inox

*Corner joint kit
Stainless steel*

PR1311

**AC1735I**

Kit per giunzione angolo
Acciaio inox

*Corner joint kit
Stainless steel*

PR1315

**AC1732I**

Kit per giunzione angolo
Acciaio inox

*Corner joint kit
Stainless steel*

PR1312

**AC1733I**

Kit per giunzione angolo
Acciaio inox

*Corner joint kit
Stainless steel*

PR1313 anta|leaf

**AC1733IE**

Kit per giunzione angolo
Acciaio inox

*Corner joint kit
Stainless steel*

PR1313 cassa|frame



ACV085

Quadro per doppia maniglia
Spindle bar for double handle



ACV944.xx

Coppia maniglie per porta
"VITRUVIO" medium
bocchetta quadrata
L | tonda | sfera

*Double door handlesets
"VITRUVIO" medium
square escutcheon
L | round | sphere*

BR ottone grezzo verniciabile | paintable untreated brass
BB ottone brunito | burnished brass



ACV085/R

Quadro per maniglia singola
Spindle bar for single handle

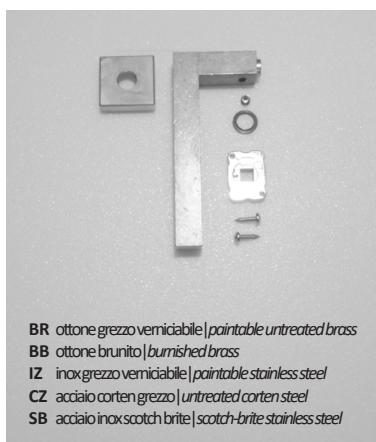

ACV947.xx

Singola maniglia per porta
"VITRUVIO" medium
bocchetta quadrata
L | quadra | tronca

*Single door handleset
"VITRUVIO" medium
square escutcheon
L | square | cut*

BR ottone grezzo verniciabile | paintable untreated brass
BB ottone brunito | burnished brass
IZ inox grezzo verniciabile | paintable stainless steel
CZ acciaio corten grezzo | untreated corten steel
SB acciaio inox scotch brite | scotch-brite stainless steel

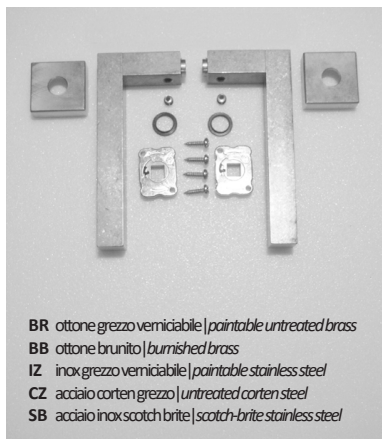

ACV942.xx

Coppia maniglie per porta
"VITRUVIO" medium
bocchetta quadrata
L | quadra | tronca

*Double door handlesets
"VITRUVIO" medium
square escutcheon
L | square | cut*

BR ottone grezzo verniciabile | paintable untreated brass
BB ottone brunito | burnished brass
IZ inox grezzo verniciabile | paintable stainless steel
CZ acciaio corten grezzo | untreated corten steel
SB acciaio inox scotch brite | scotch-brite stainless steel

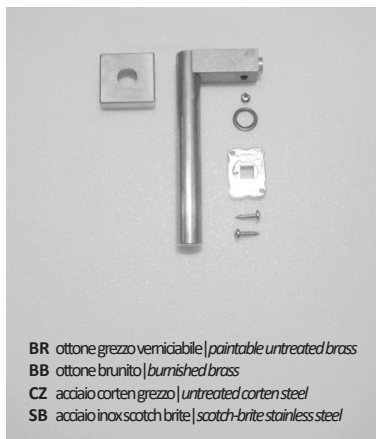

ACV948.xx

Singola maniglia per porta
"VITRUVIO" medium
bocchetta quadrata
L | tonda | tronca

*Single door handleset
"VITRUVIO" medium
square escutcheon
L | round | cut*

BR ottone grezzo verniciabile | paintable untreated brass
BB ottone brunito | burnished brass
CZ acciaio corten grezzo | untreated corten steel
SB acciaio inox scotch brite | scotch-brite stainless steel

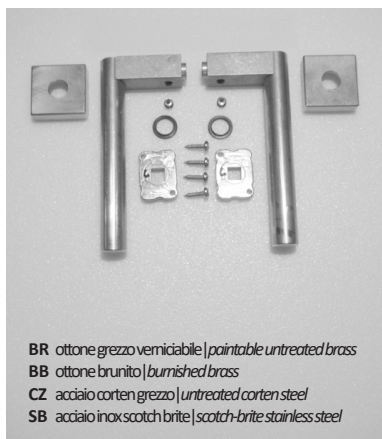

ACV943.xx

Coppia maniglie per porta
"VITRUVIO" medium
bocchetta quadrata
L | tonda | tronca

*Double door handlesets
"VITRUVIO" medium
square escutcheon
L | round | cut*

BR ottone grezzo verniciabile | paintable untreated brass
BB ottone brunito | burnished brass
CZ acciaio corten grezzo | untreated corten steel
SB acciaio inox scotch brite | scotch-brite stainless steel



ACV949.xx

Singola maniglia per porta
"VITRUVIO" medium
bocchetta quadrata
L | tonda | sfera

*Single door handleset
"VITRUVIO" medium
square escutcheon
L | round | sphere*

BR ottone grezzo verniciabile | paintable untreated brass
BB ottone brunito | burnished brass

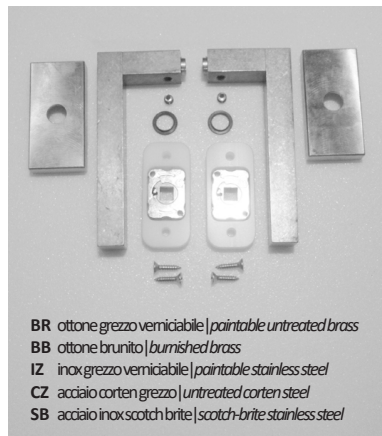
**ACV952.xx**

Coppia maniglie per porta
"VITRUVIO" medium
bocchetta rettangolare
L | quadra | tronca

*Double door handlesets
"VITRUVIO" medium
rectangular escutcheon
L | square | cut*

BR ottone grezzo verniciabile | *paintable untreated brass*
BB ottone brunito | *burnished brass*
IZ inox grezzo verniciabile | *paintable stainless steel*
CZ acciaio corten grezzo | *untreated corten steel*
SB acciaio inox scotch brite | *scotch-brite stainless steel*

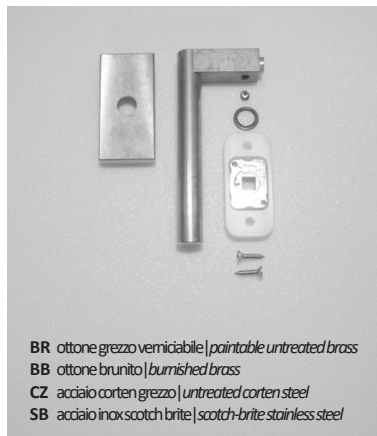
**ACV958.xx**

Singola maniglia per porta
"VITRUVIO" medium
bocchetta rettangolare
L | tonda | tronca

*Single door handleset
"VITRUVIO" medium
rectangular escutcheon
L | round | cut*

BR ottone grezzo verniciabile | *paintable untreated brass*
BB ottone brunito | *burnished brass*
CZ acciaio corten grezzo | *untreated corten steel*
SB acciaio inox scotch brite | *scotch-brite stainless steel*

**ACV953.xx**

Coppia maniglie per porta
"VITRUVIO" medium
bocchetta rettangolare
L | tonda | tronca

*Double door handlesets
"VITRUVIO" medium
rectangular escutcheon
L | round | cut*

BR* ottone grezzo verniciabile | *paintable untreated brass*
BB* ottone brunito | *burnished brass*
CZ acciaio corten grezzo | *untreated corten steel*
SB acciaio inox scotch brite | *scotch-brite stainless steel*

*quadro maniglia compreso
**handle spindle bar included*

**ACV959.xx**

Singola maniglia per porta
"VITRUVIO" medium
bocchetta rettangolare
L | tonda | sfera

*Single door handleset
"VITRUVIO" medium
rectangular escutcheon
L | round | sphere*

BR ottone grezzo verniciabile | *paintable untreated brass*
BB ottone brunito | *burnished brass*

**ACV954.xx**

Coppia maniglie per porta
"VITRUVIO" medium
bocchetta rettangolare
L | tonda | sfera

*Double door handlesets
"VITRUVIO" medium
rectangular escutcheon
L | round | sphere*

BR ottone grezzo verniciabile | *paintable untreated brass*
BB ottone brunito | *burnished brass*

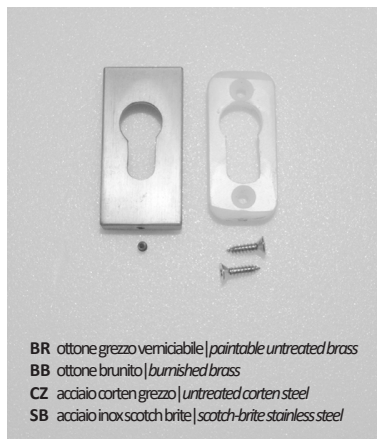
**ACV964.xx**

Bocchetta copri cilindro a profilo
europeo

*Euro profile cylinder escutcheon
plate*

BR ottone grezzo verniciabile | *paintable untreated brass*
BB ottone brunito | *burnished brass*
CZ acciaio corten grezzo | *untreated corten steel*
SB acciaio inox scotch brite | *scotch-brite stainless steel*

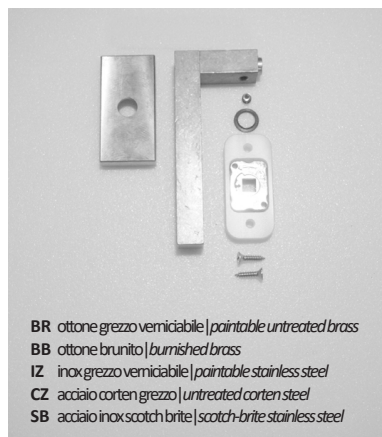
**ACV957.xx**

Singola maniglia per porta
"VITRUVIO" medium
bocchetta rettangolare
L | quadra | tronca

*Single door handleset
"VITRUVIO" medium
rectangular escutcheon
L | square | cut*

BR ottone grezzo verniciabile | *paintable untreated brass*
BB ottone brunito | *burnished brass*
IZ inox grezzo verniciabile | *paintable stainless steel*
CZ acciaio corten grezzo | *untreated corten steel*
SB acciaio inox scotch brite | *scotch-brite stainless steel*

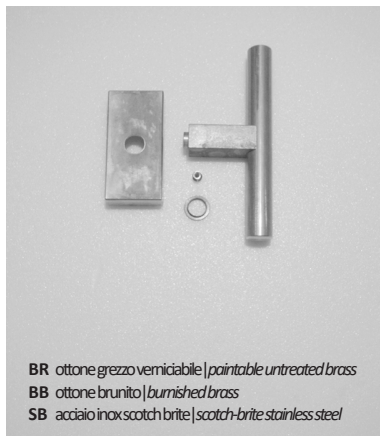
**ACV971.xx**

Maniglia per DK
finestra "VITRUVIO" medium
T | tonda | tronca

*DK window handle
"VITRUVIO" medium
T | round | cut*

BR ottone grezzo verniciabile | *paintable untreated brass*
BB ottone brunito | *burnished brass*
SB acciaio inox scotch brite | *scotch-brite stainless steel*

**ACV976.xx**

Maniglia per DK finestra
"VITRUVIO" medium
KIDS

*DK window handle
"VITRUVIO" medium
KIDS*

BR ottone grezzo verniciabile | *paintable untreated brass*
BB ottone brunito | *burnished brass*

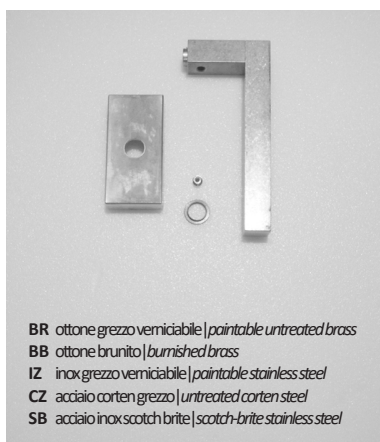
**ACV972.xx**

Maniglia per DK finestra
"VITRUVIO" medium
L | quadra | tronca

*DK window handle
"VITRUVIO" medium
L | square | cut*

BR ottone grezzo verniciabile | *paintable untreated brass*
BB ottone brunito | *burnished brass*
IZ inox grezzo verniciabile | *paintable stainless steel*
CZ acciaio corten grezzo | *untreated corten steel*
SB acciaio inox scotch brite | *scotch-brite stainless steel*

**ACV977.xx**

Maniglia per DK finestra
"VITRUVIO" medium
OVALE

*DK window handle
"VITRUVIO" medium
OVALE*

BR ottone grezzo verniciabile | *paintable untreated brass*
BB ottone brunito | *burnished brass*

**ACV973.xx**

Maniglia per DK finestra
"VITRUVIO" medium
L | tonda | tronca

*DK window handle
"VITRUVIO" medium
L | round | cut*

BR ottone grezzo verniciabile | *paintable untreated brass*
BB ottone brunito | *burnished brass*
CZ acciaio corten grezzo | *untreated corten steel*
SB acciaio inox scotch brite | *scotch-brite stainless steel*

**ACV979.xx**

Maniglia per DK finestra
"VITRUVIO" medium
T | tonda | sfera

*DK window handle
"VITRUVIO" medium
T | round | sphere*

BR ottone grezzo verniciabile | *paintable untreated brass*
BB ottone brunito | *burnished brass*

**ACV974.xx**

Maniglia per DK finestra
"VITRUVIO" medium
L | tonda | sfera

*DK window handle
"VITRUVIO" medium
L | round | sphere*

BR ottone grezzo verniciabile | *paintable untreated brass*
BB ottone brunito | *burnished brass*

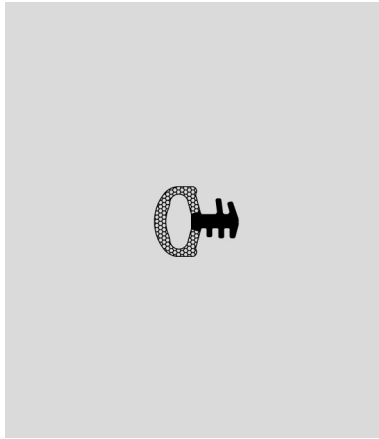

GE1001TT

Guarnizione di battuta per porte e finestre

Gasket for doors and windows

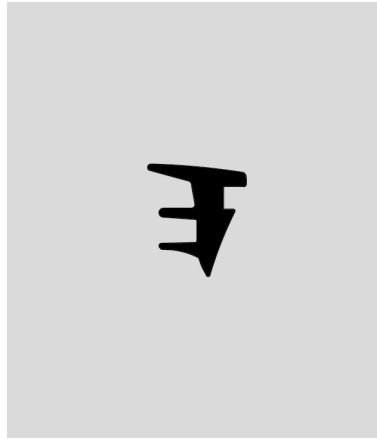

GE1012

Guarnizione interna fermavetro spessore 6-8 mm

Internal gasket for 6-8 mm thick glazing bead

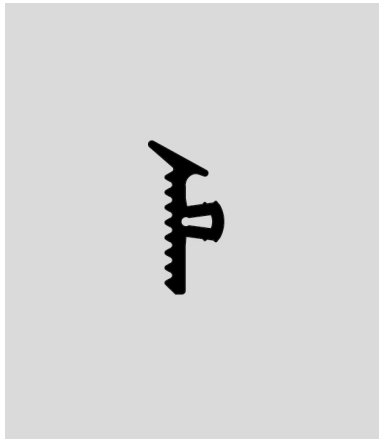

GE1006

Guarnizione esterna vetro

External gasket

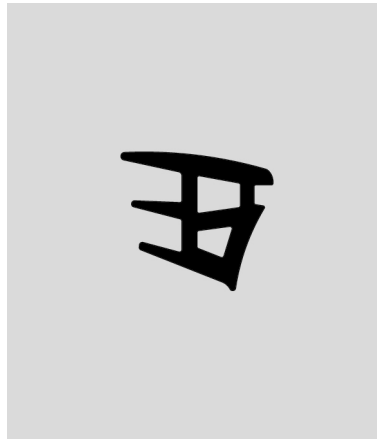

GE1013

Guarnizione interna fermavetro spessore 12-16 mm

Internal gasket for 12-16 mm thick glazing bead

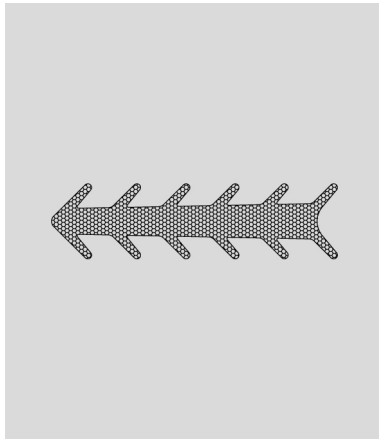

GE1007TT

Guarnizione sotto vetro

Under glass gasket

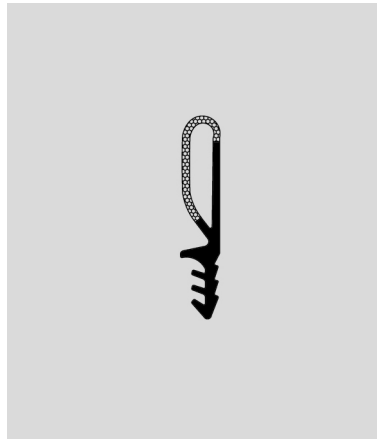

GE1200TT

Guarnizione di battuta interna per finestre

Internal gasket for windows



GE1011

Guarnizione interna fermavetro spessore 3-4 mm

Internal gasket for 3-4 mm thick glazing bead

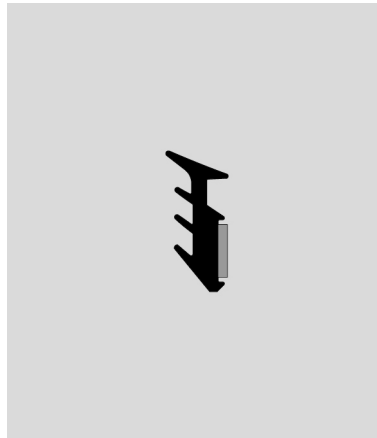

GE1206

Guarnizione autoadesiva per lato esterno vetro su PR1233 | PR1724

Self-adhesive external gasket for PR1233 | PR1724

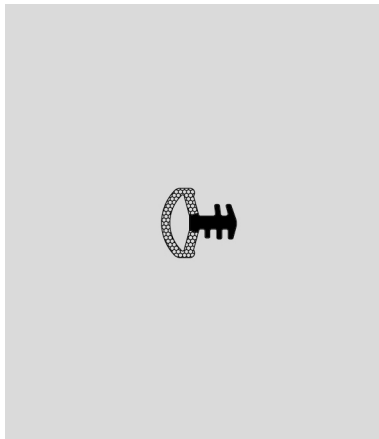

GE1233TT

Guarnizione di battuta per finestre

Gasket for windows

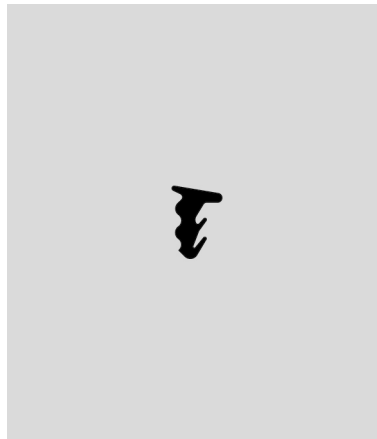

GE2029

Guarnizione interna dividivetro PR2030 | PR2031 | PR2032

Internal gasket for glass divider on PR2030 | PR2031 | PR2032

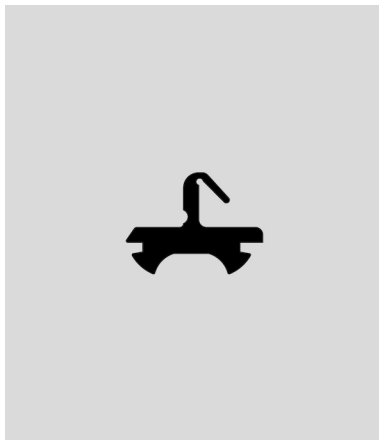

GE1701

Guarnizione centrale di battuta giunto aperto finestre telaio - nodo TZT

Central open-joint gasket for windows frame - TZT profiles

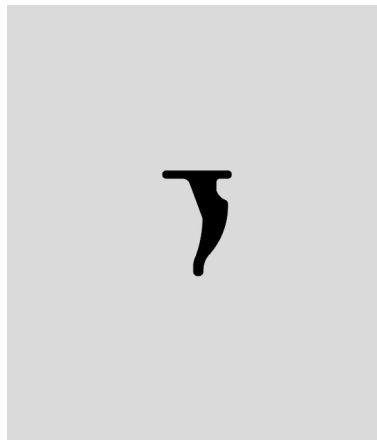

GP0095

Guarnizione interna fermavetro spessore 3 mm

Internal gasket for glazing bead, 3mm thick

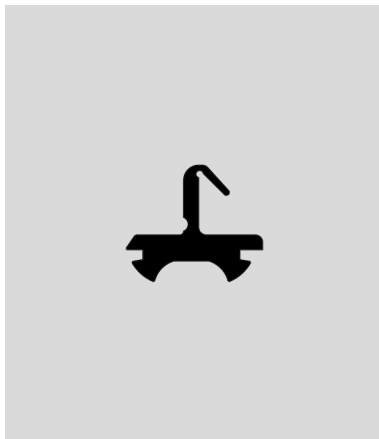

GE1704

Guarnizione centrale di battuta giunto aperto finestre anta PR1924 - nodo TZ

Central open-joint gasket for windows leaf PR1924 - TZ profiles

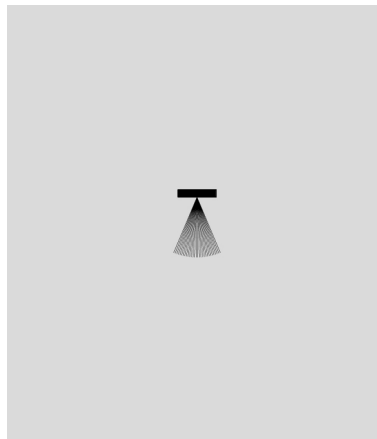

GU0087

Spazzolino per porte su GU0120 H=8 mm

Brush for doors on GU0120 H=8 mm

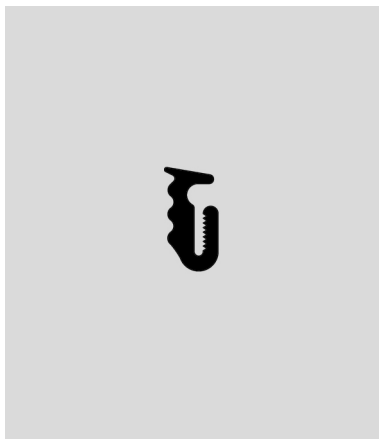

GE2028

Guarnizione interna per fermavetro PR2028

Gasket for glazing bead P,2028

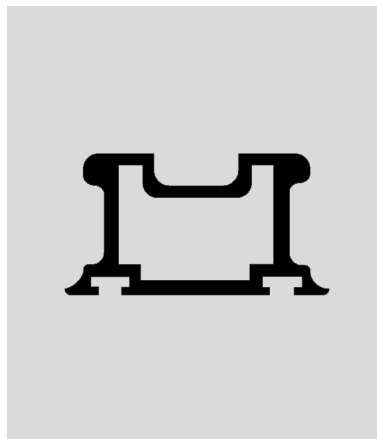

GU0120

Estruso in PVC porta spazzolino per porte

Extruded PVC brush holder for doors

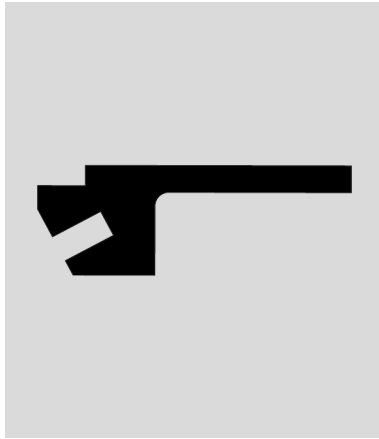
**GU1134**

Estruso rigido in PVC per soglia porta PR1130

Rigid extruded PVC section for PR1130 threshold

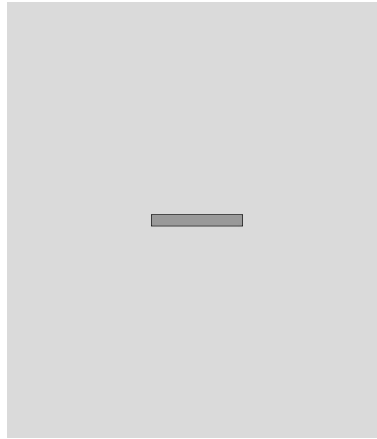
**GU2031**

Biadesivo per dividivetro 12x1.5 mm

Bi-adhesive tape for glass divider 12x1.5 mm

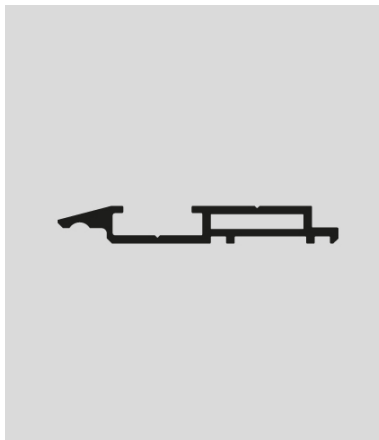
**GU1302**

Estruso rigido in PVC per GE1701-GE1704

Rigid extruded PVC section for GE1701-GE1704

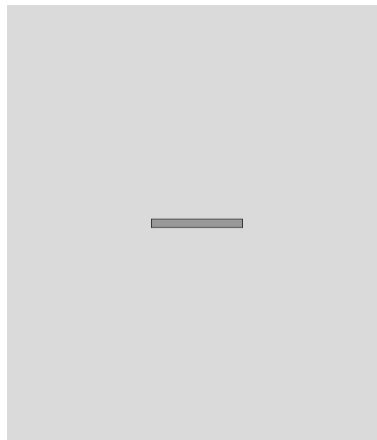
**GU2032**

Biadesivo per dividivetro 12x1 mm

Bi-adhesive tape for glass divider 12x1 mm

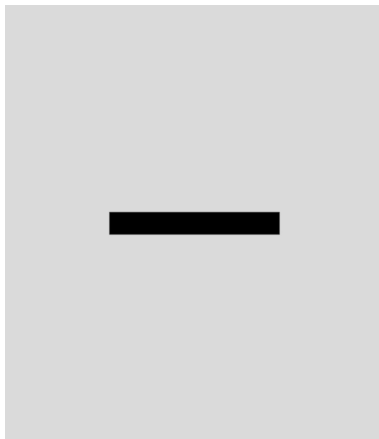
**GU1311**

Profilo in PVC per scarico acqua aperture a sporgere

PVC profile for water drain in awning opening

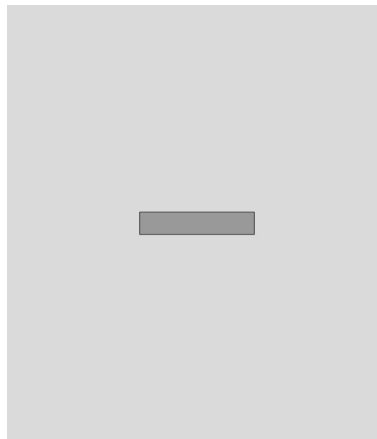
**GU2035**

Piattina adesiva morbida per fondo giunto esterno vetro 15x3 mm

Soft adhesive shim for external window joint 15x3 mm

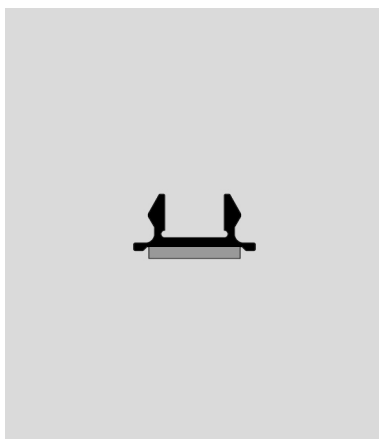
**GU2030E**

Profilo in PVC con biadesivo per fissaggio dividivetro interno PR2030 | PR2031 | PR2032

PVC profile with double-sided tape for fixing internal glass divider on PR2030 | PR2031 | PR2032



AT1001

Maschera per esecuzione fori di fissaggio squadretta su profili maggiorati

Jig for drilling holes for corner plate on oversize profiles



AT1242

Maschera per esecuzione fori fissaggio cerniere A/R in acciaio inox

Jig for drilling holes for tilt-turn hinges in stainless steel

AGE291-2-5-6

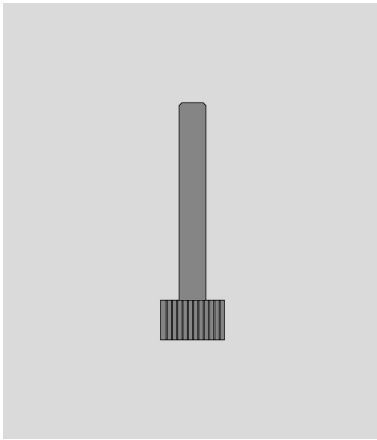

AT1058

Fresa per lavorazione spacco cerniera AC1068

Milling cutter for hinge slot AC1068

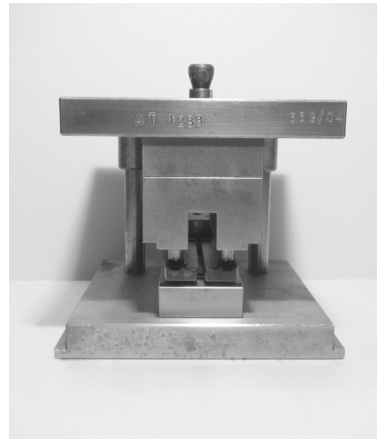

AT1333

Stampo per esecuzione fori di fissaggio squadretta su profilo PR1333 | PR1924

Die for drilling holes for corner plate on profile PR1333 | PR1924

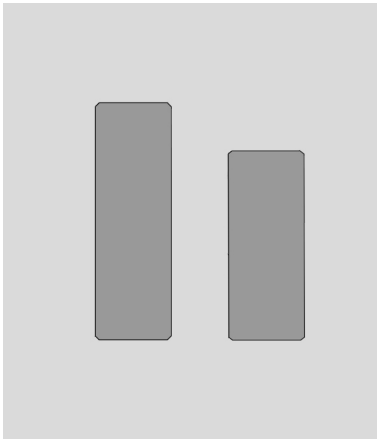

AT1100

Ganasce di taglio per profili EBE85
Cutting jaws for profiles EBE85

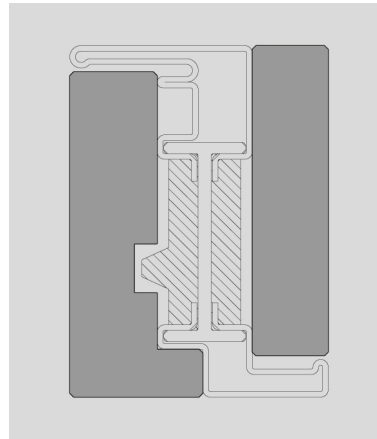

AT1336

Ganasce di taglio per profilo PR1333

Cutting jaws for PR1333

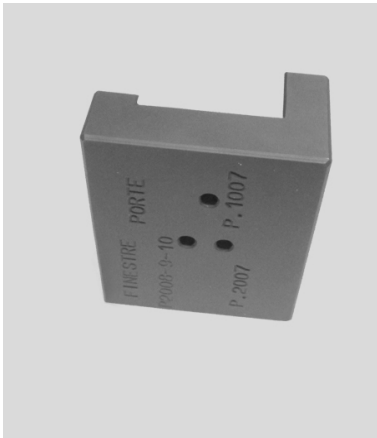

AT1234

Maschera per esecuzione fori fissaggio fermavetri con boccole

Jig for drilling holes for glazing bead with bushings

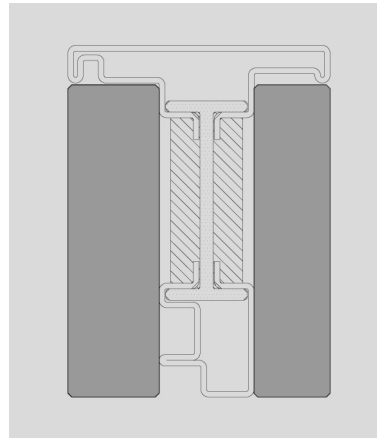

AT1924

Ganasce di taglio per profilo PR1924 - PR1902

Cutting jaws for PR1924 - PR1902

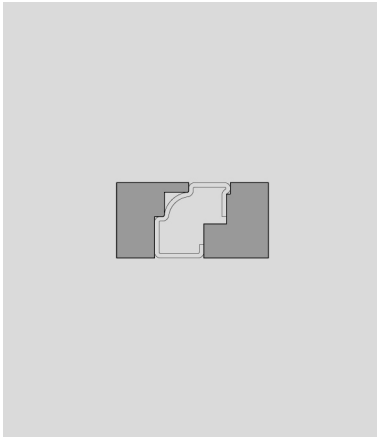

AT2029

Ganasce di taglio per fermavetro PR2028

Cutting jaws for glazing bead PR2028

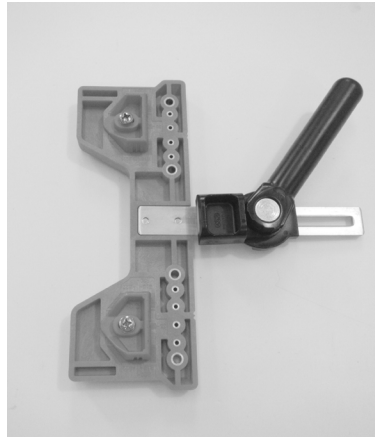

ATG271

Dima per esecuzione fori montaggio A/R cerniere a sormonto

Template for drilling holes for tilt-turn kit with overlap hinges

AGE271-2-5-6

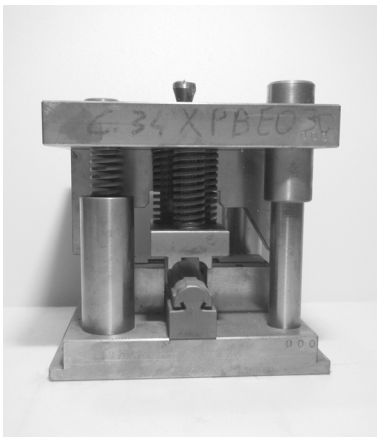

AT2030

Stampo per intestatura PR2030

Butt die for PR2030



ATG281

Kit dime per esecuzione fori montaggio A/R cerniere a scomparsa

Template kit for drilling holes for tilt-turn kit with concealed hinges

AGE281-2-5-6

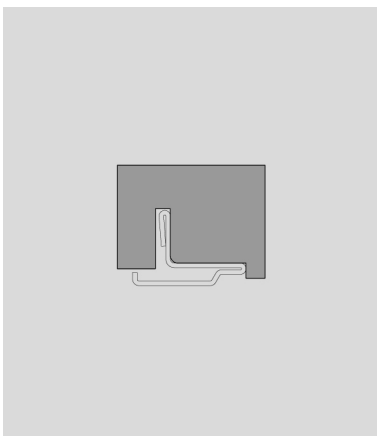

AT2038

Ganasce di taglio per PR2038

Cutting jaws for PR2038



ATG303

Maschera per esecuzione fori montaggio riscontri nottolini RC2

Jig for drilling holes for cam strikes RC2



AT2828

Maschera per esecuzione fori fissaggio fermavetri con clips

Jig for drilling holes for glazing bead with clips

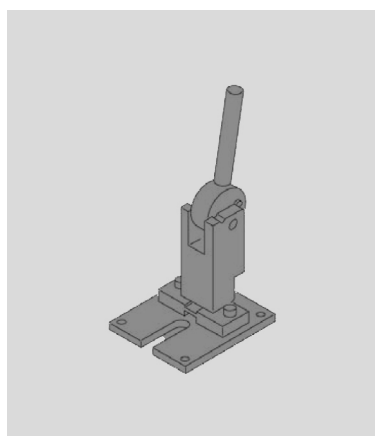

ATG311

Trancia manuale

Manual punching machine

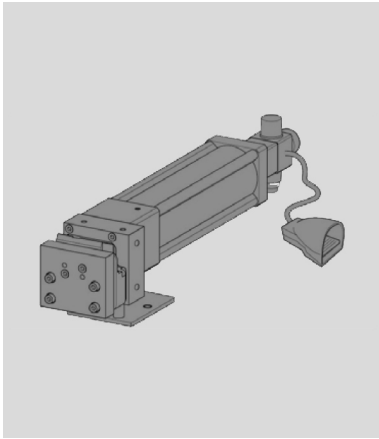
**ATG312**

Trancia oleopneumatica

Oil-pneumatic punching machine

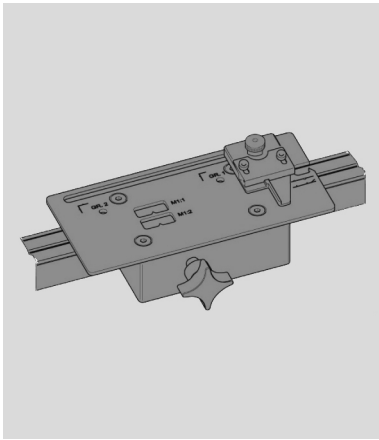
**ATG313**

Asta millimetrata per trancia oleopneumatica

Rod divided into millimetres for oil-pneumatic punching machine

**SA0005.01**

Liquido brunitore per ottone
1 l

*Burnishing liquid for brass
1 l*

SA0005.10

Liquido brunitore per ottone
10 l

*Burnishing liquid for brass
10 l*

**SA2001**

Spray detergente antimpronta
per superfici in acciaio inox

*Anti-fingerprint detergent spray
for stainless steel surfaces*

**SA0070.01**

Liquido brunitore per acciaio
inox
1 l

*Burnishing liquid for stainless
steel
1 l*

**SA2002**

Spray solvente per rimozione
collanti su superfici in acciaio
inox

*Solvent adhesive remover spray
for stainless steel surfaces*

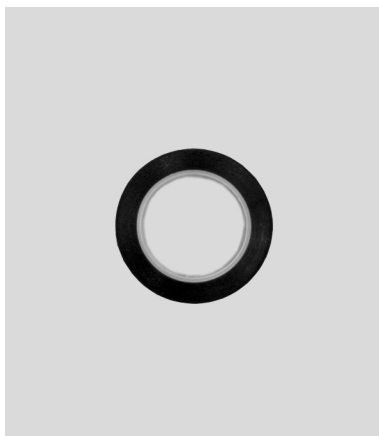
**SA1042**

Nastro adesivo protettivo per
verniciatura
42 mm

*Adhesive tape for painting
42 mm*

**SA2031**

Liquido deumidificante vetri

Glass dehumidifying liquid

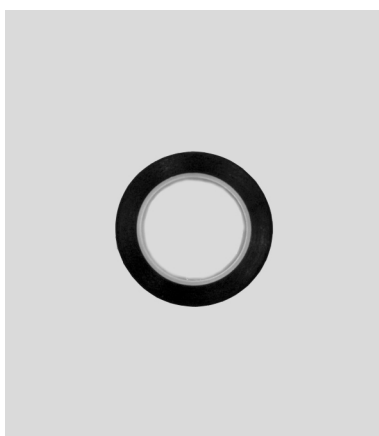
**SA1052**

Nastro adesivo protettivo per
verniciatura
52 mm

*Adhesive tape for painting
52 mm*

**SA2032**

Primer di adesione per profili
verniciati

*Adhesion primer for painted
profiles*



SA2033

Liquido di adesione per materiale plastico

Adhesion liquid for plastic



SA3004

Cera d'api per finitura ottone

5 kg

Beeswax for brass finishing
5 kg



SA3001

Acido per ossidazione corten

Oxidising acid for corten



SL0019

Sigillante a freddo per giunzione angoli e traversi

Cold sealant for corner and transom joints

1 kg

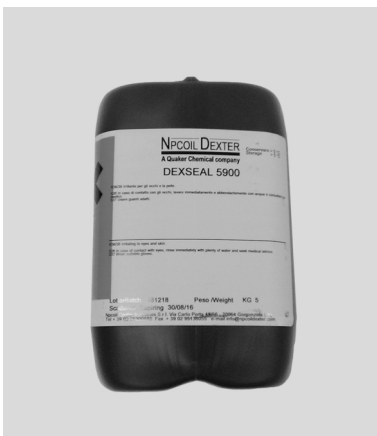

SA3002.05

Passivante per ossidazione corten

5 kg

Passivating agent for corten
5 kg

SA3002.25

Passivante per ossidazione corten

25 kg

Passivating agent for corten
25 kg



SL0021

Silicone nero per guarnizioni

Black silicone for gaskets



SA3003

Cera d'api per finitura corten

5 l

Beeswax for Corten finishing
5 l







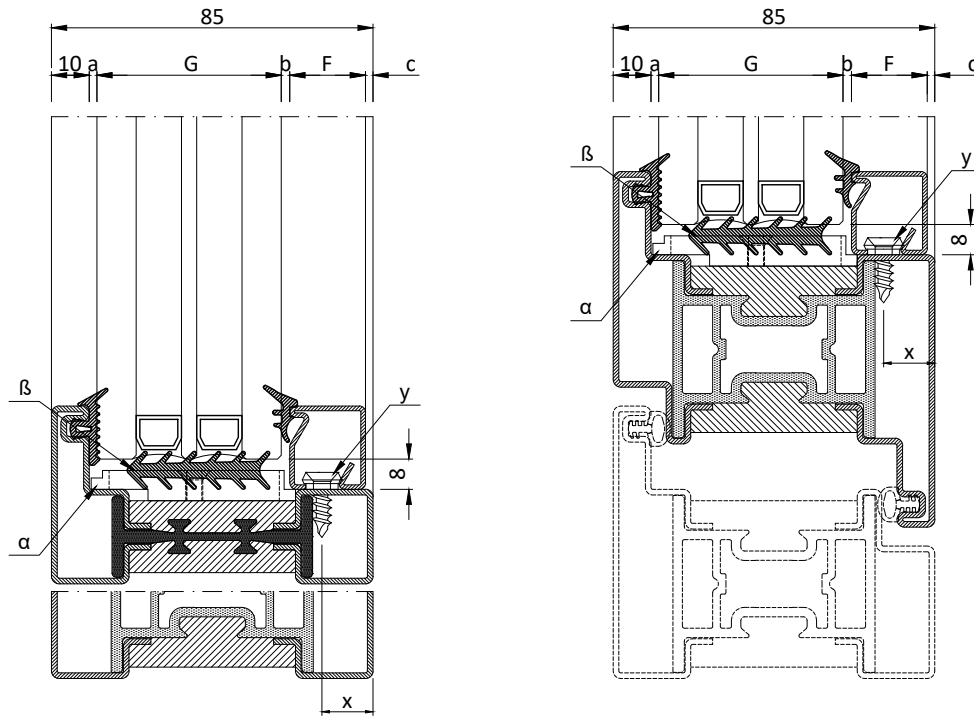

SL0100

Silicone strutturale grigio per vetri

RC2

Gray structural silicone for glass
RC2

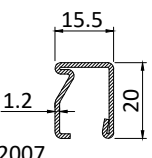
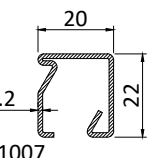
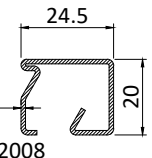

F	G	Guarnizioni - gaskets										
fermavetro glazing bead	range vetro glass range	GE1006 3 mm 	GP0095 2 / 3 mm 	GE1011 3 / 4 mm 	GE1012 6 / 8 mm 	GE1013 12 / 16 mm 	asse fissaggio viti fermavetro securing axis for screws for the glazing beads	rientro fermavetro glazing beads gap	boccole e viti fissaggio fermavetro Bushings and screws for glazing bead fixing	spessore per vetro glass shim	guarnizione sotto vetro under glass gasket	
Code		a	b	b	b	b	x	c	y	α	β	
 PR2007	38 - 54	3	51 - 52	50 - 51	46 - 48	38 - 42	9.5	2	CV5001(i) CV5012(i)	AC1020XL	GE1007TT	
			53 - 54	52 - 53	48 - 50	40 - 44	7.5	0				
 PR1007	38 - 50		47 - 48	46 - 47	42 - 44	38 min	13.5	2	CV5001(i) CV5012(i)	AC1020XL	GE1007TT	
			49 - 50	48 - 49	44 - 46	38 min - 40	11.5	0				
 PR2008	39 - 45		-	-	-	-	-	-	-	CV5001(i) CV5012(i)	AC1020XS	GE1007TT
			44 - 45	43 - 44	39 - 41	-	16	0				

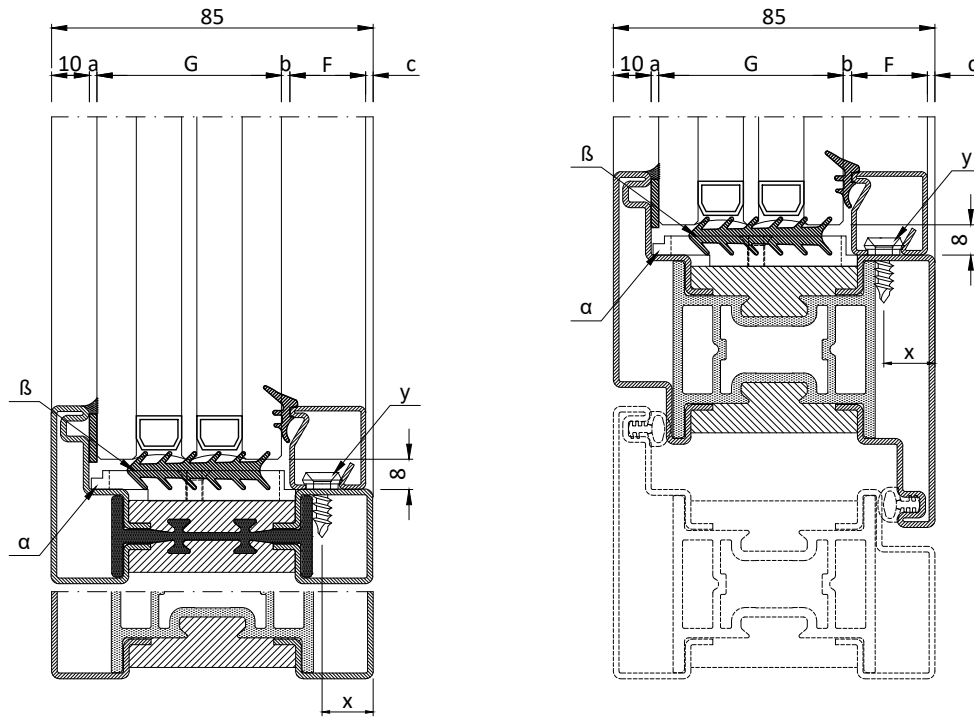

F	G	Guarnizioni - gaskets									
fermavetro glazing bead	range vetro glass range	GU2035 2 mm + sigillatura + sealing	GP0095 2 / 3 mm 	GE1011 3 / 4 mm 	GE1012 6 / 8 mm 	GE1013 12 / 16 mm 	asse fissaggio viti fermavetro securing axis for screws for the glazing beads	rientro fermavetro glazing beads gap	boccole e viti fissaggio fermavetro Bushings and screws for glazing bead fixing	spessore per vetro glass shim	guarnizione sotto vetro under glass gasket
Code		a	b	b	b	b	x	c	y	α	β
 PR2007	39 - 55	2	52	51	47	39	9.5	2	CV5001(i) CV5012(i)	AC1020XL	GE1007TT
			53	52	49	43					
 PR1007	38 - 51		54	53	49	41	7.5	0	CV5001(i) CV5012(i)	AC1020XL	GE1007TT
			55	54	51	45					
 PR2008	40 - 46		-	-	-	-	-	-	CV5001(i) CV5012(i)	AC1020XS	GE1007TT
			45	44	40	-					
			46	45	42						

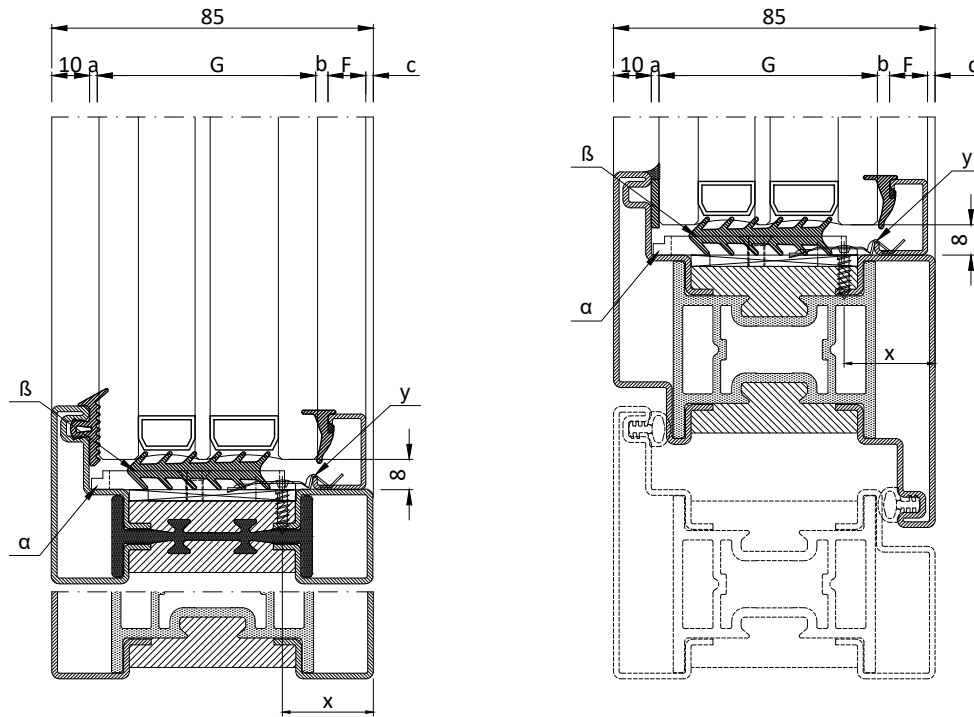

F		Guarnizioni - gaskets		G						
fermavetro glazing bead	range vetro glass range	GE1006 3 mm 	GP0095 3 mm 	spessore vetro glass thickness	asse fissaggio viti fermavetro securing axis for screws for the glazing beads	rientro fermavetro glazing beads gap	clips fissaggio fermavetro securing clips for glazing beads	spessore di compensazione * Shim *	spessore per vetro glass shim	guarnizione sotto vetro under glass gasket
Code		a	b	mm.	x	c	y	z	alpha	beta
 PR2015	57	3	3	57	31	2	AC2608	3 mm.	AC1020XL	GE1007TT
	59			59	29	0				

F		Guarnizioni - gaskets		G						
fermavetro glazing bead	range vetro glass range	GU2035 2 mm + sigillatura + sealing	GP0095 3 mm 	spessore vetro glass thickness	asse fissaggio viti fermavetro securing axis for screws for the glazing beads	rientro fermavetro glazing beads gap	clips fissaggio fermavetro securing clips for glazing beads	spessore di compensazione * Shim *	spessore per vetro glass shim	guarnizione sotto vetro under glass gasket
Code		a	b	mm.	x	c	y	z	alpha	beta
 PR2015	58	2	3	58	31	2	AC2608	3 mm.	AC1020XL	GE1007TT
	60			60	29	0				

*non fornito
*not included

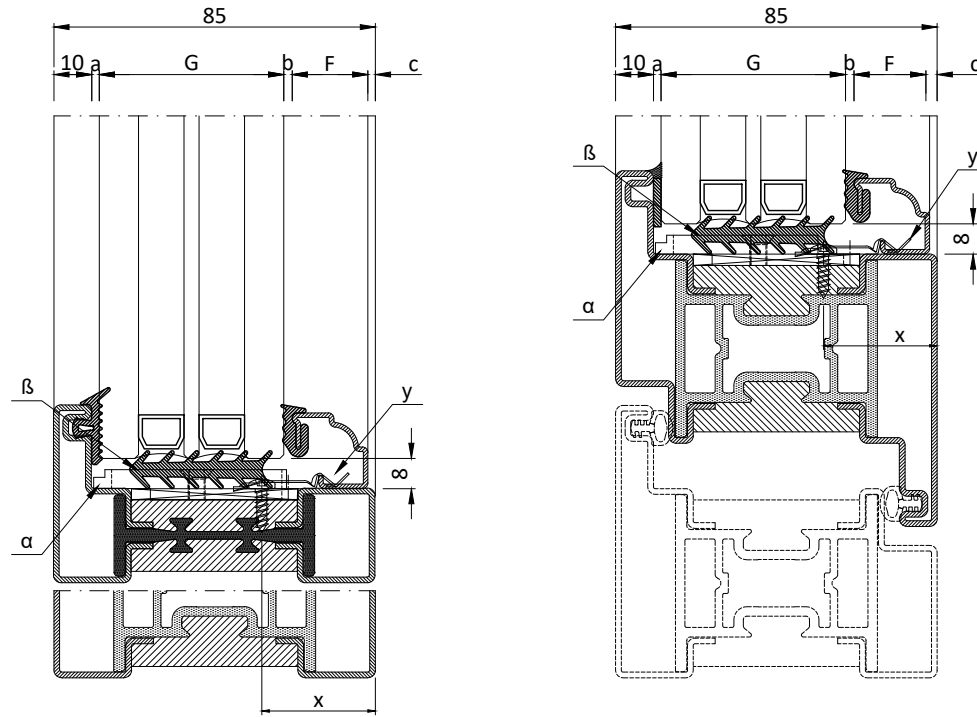

F		Guarnizioni - gaskets		G						
fermavetro glazing bead	range vetro glass range	GE1006 3 mm 	GE2028 2.5 mm 	spessore vetro glass thickness	asse fissaggio viti fermavetro securing axis for screws for the glazing beads	rientro fermavetro glazing beads gap	clips fissaggio fermavetro securing clips for glazing beads	spessore di compensazione * Shim *	spessore per vetro glass shim	guarnizione sotto vetro under glass gasket
Code		a	b	mm.	x	c	y	z	α	β
 PR2028	44 - 50	3	2.5	44	34	6	AC2608	3 mm.	AC1020XL	GE1007TT
				46	32	4				
				48	30	2				
				50	28	0				

F		Guarnizioni - gaskets		G						
fermavetro glazing bead	range vetro glass range	GU2035 2 mm + sigillatura + sealing	GE2028 2.5 mm 	spessore vetro glass thickness	asse fissaggio viti fermavetro securing axis for screws for the glazing beads	rientro fermavetro glazing beads gap	clips fissaggio fermavetro securing clips for glazing beads	spessore di compensazione * Shim *	spessore per vetro glass shim	guarnizione sotto vetro under glass gasket
Code		a	b	mm.	x	c	y	z	α	β
 PR2028	45 - 51	2	2.5	45	34	6	AC2608	3 mm.	AC1020XL	GE1007TT
				47	32	4				
				49	30	2				
				51	28	0				

*non fornito
*not included

Taglio a 45° dei fermavetri effettuabile utilizzando la ganascia AT2029
45° cutting of the glazing beads done using the cutting jaw AT2029

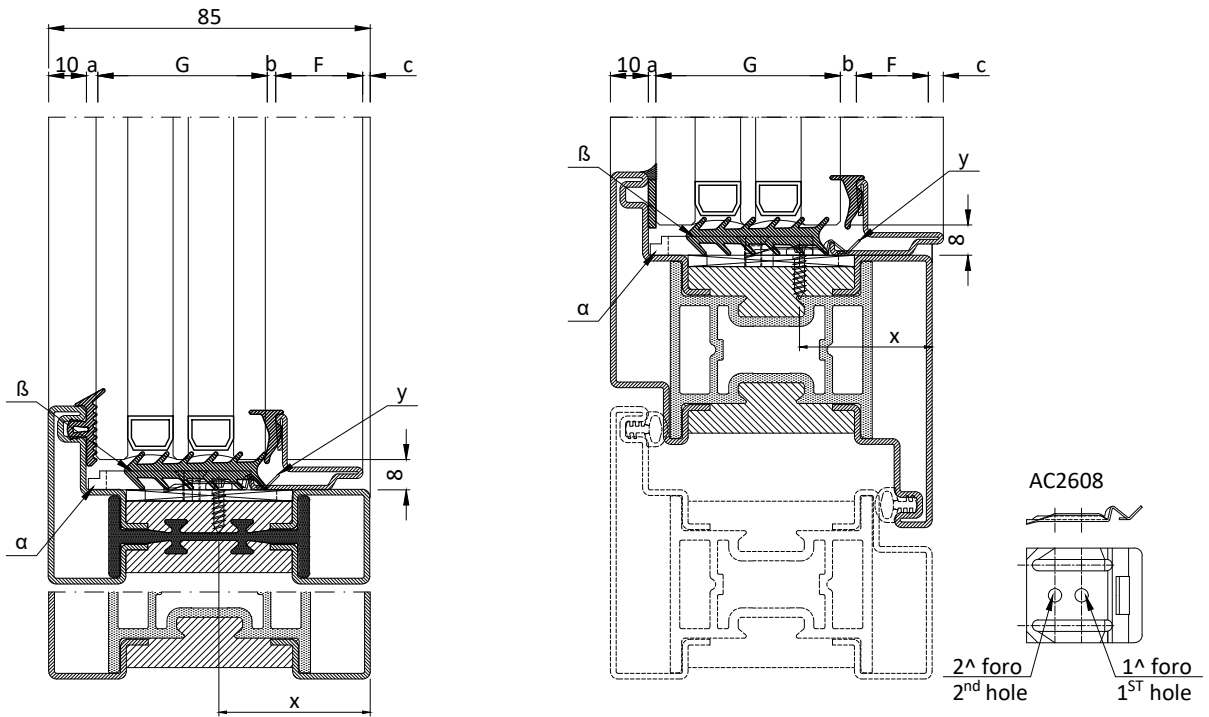

F		Guarnizioni - gaskets		G						
fermavetro glazing bead	range vetro glass range	GE1006 3 mm 	GP0095 3 mm 	spessore vetro glass thickness	asse fissaggio viti fermavetro securing axis for screws for the glazing beads	rientro fermavetro glazing beads gap	clips fissaggio fermavetro securing clips for glazing beads	spessore di compensazione * Shim *	spessore per vetro glass shim	guarnizione sotto vetro under glass gasket
Code		a	b	mm.	x	c	y	z	α	β
 PR2038	44 - 50	3	3	44 46 48 50	40** 38** 36** 34**	2 0 -2 -4	AC2608	3 mm.	AC1020XS	GE1007TT

F		Guarnizioni - gaskets		G						
fermavetro glazing bead	range vetro glass range	GU2035 2 mm + sigillatura + sealing	GP0095 3 mm 	spessore vetro glass thickness	asse fissaggio viti fermavetro securing axis for screws for the glazing beads	rientro fermavetro glazing beads gap	clips fissaggio fermavetro securing clips for glazing beads	spessore di compensazione * Shim *	spessore per vetro glass shim	guarnizione sotto vetro under glass gasket
Code		a	b	mm.	x	c	y	z	α	β
 PR2038	45 - 51	2	3	45 47 49 51	40** 38** 36** 34**	2 0 -2 -4	AC2608	3 mm.	AC1020XS	GE1007TT

*non fornito
*not included

** fissare tramite il primo foro della clip
** screw in the upper hole of the clip

Taglio a 45° dei fermavetri effettuabile utilizzando la ganascia AT2038
45° cutting of the glazing beads done using the cutting jaw AT2038



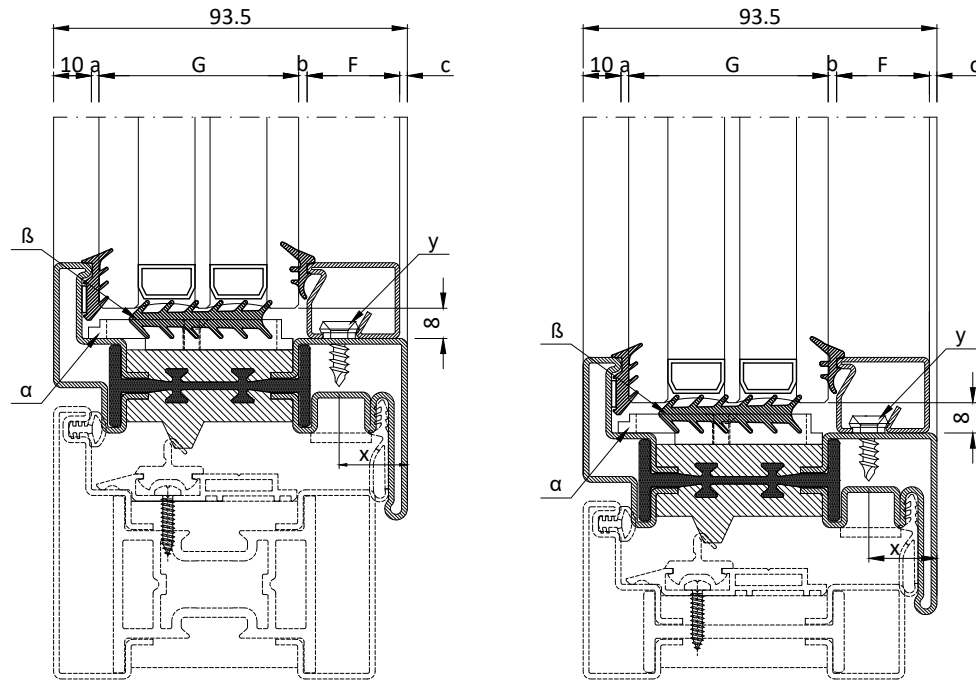

F	G	Guarnizioni - gaskets										
fermavetro glazing bead	range vetro glass range	GE1206 3 mm	GP0095 2 / 3 mm	GE1011 3 / 4 mm	GE1012 6 / 8 mm	GE1013 12 / 16 mm	asse fissaggio viti fermavetro securing axis for screws for the glazing beads	rientro fermavetro glazing beads gap	boccole e viti fissaggio fermavetro Bushings and screws for glazing bead fixing	spessore per vetro glass shim	guarnizione sotto vetro under glass gasket	
Code		a	b	b	b	b	x	c	y	α	β	
 PR2007	47 - 63	3	60	59	55	47	9.5	2	CV5001(i) CV5012(i)	AC1020XL	GE1007TT	
			61	60	57	51						
			62	61	57	29	7.5	0				
			63	62	59	53						
 PR1007	43 - 59		56	55	51	43	13.5	2	CV5001(i) CV5012(i)	AC1020XL	GE1007TT	
			57	56	53	47						
			58	57	53	45	11.5	0				
			59	58	35	49						
 PR2008	38 - 54	51	50	46	38	18	2	CV5001(i) CV5012(i)	AC1020XL	GE1007TT		
		52	51	48	42							
		53	52	48	40	16	0					
		54	53	50	44							
 PR2009	38 - 44	41	40	38 min.	-	18	2	CV5001(i) CV5012(i)	AC1020XS	GE1007TT		
		42	41									
		43	42	38	-	16	0					
		44	43	40								

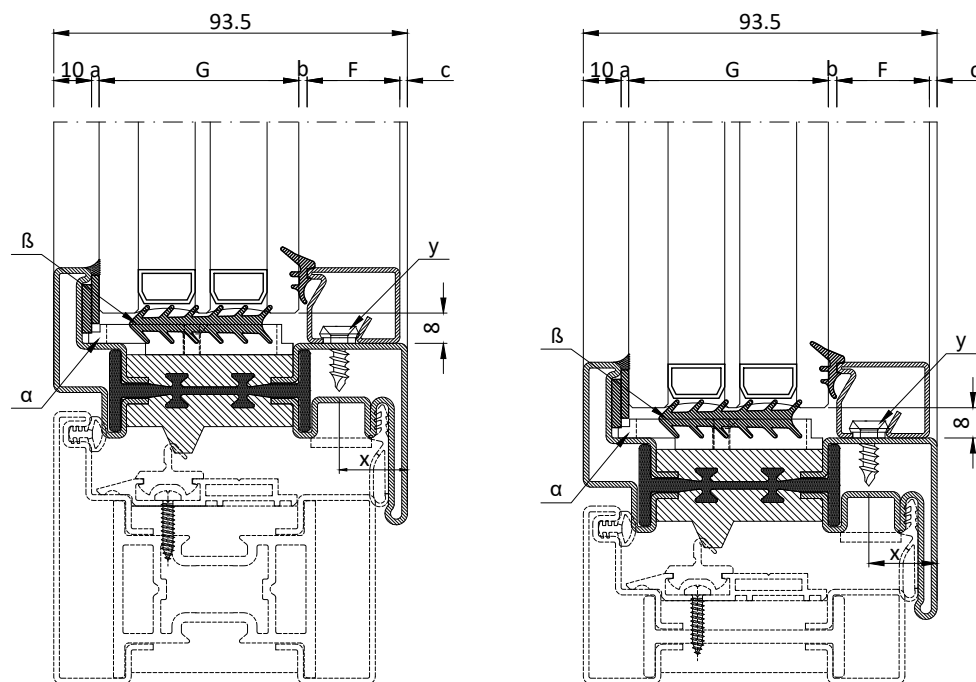

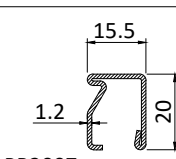
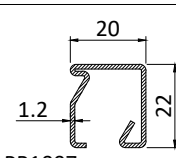
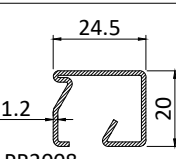
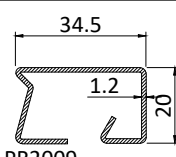
F	G	Guarnizioni - gaskets									
fermavetro glazing bead	range vetro glass range	GU2035 2 mm + sigillatura + sealing	GP0095 2 / 3 mm	GE1011 3 / 4 mm	GE1012 6 / 8 mm	GE1013 12 / 16 mm	asse fissaggio viti fermavetro securing axis for screws for the glazing beads	rientro fermavetro glazing beads gap	boccole e viti fissaggio fermavetro Bushings and screws for glazing bead fixing	spessore per vetro glass shim	guarnizione sotto vetro under glass gasket
Code		a	b	b	b	b	x	c	y	α	β
 PR2007	48 - 64	2	61	60	56	48	9.5	2	CV5001(i) CV5012(i)	AC1020XL	GE1007TT
			62	61	58	52					
			63	62	58	50	7.5	0			
			64	63	60	54					
 PR1007	44 - 60		57	56	52	44	13.5	2	CV5001(i) CV5012(i)	AC1020XL	GE1007TT
			58	57	54	48					
			59	58	54	46	11.5	0			
			60	59	56	50					
 PR2008	39 - 55	52	51	47	39	18	2	CV5001(i) CV5012(i)	AC1020XL	GE1007TT	
		53	52	49	43						
		54	53	49	41	16	0				
		55	54	51	45						
 PR2009	38 - 45	42	41	38 min.	-	18	2	CV5001(i) CV5012(i)	AC1020XS	GE1007TT	
		43	42								
		44	43	39	-	16	0				
		45	44	41	-						

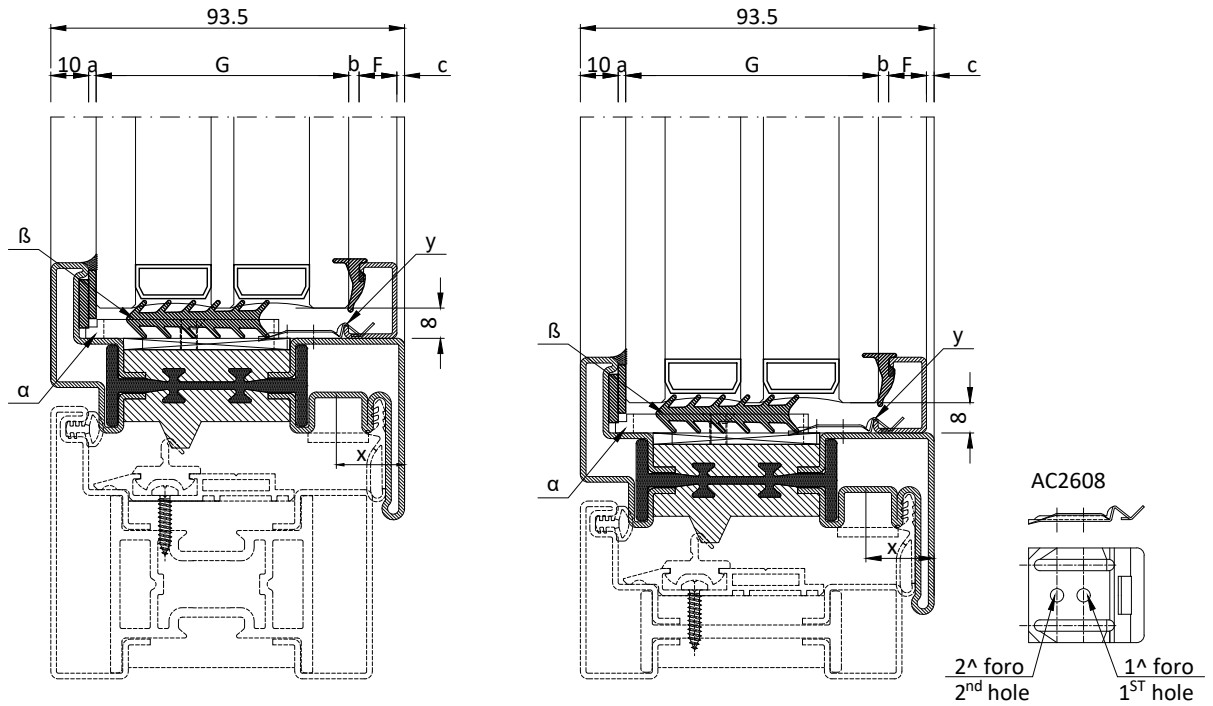

F		Guarnizioni - gaskets		G						
fermavetro glazing bead	range vetro glass range	GE1206 3 mm 	GP0095 3 mm 	spessore vetro glass thickness	asse fissaggio viti fermavetro securing axis for screws for the glazing beads	rientro fermavetro glazing beads gap	clips fissaggio fermavetro securing clips for glazing beads	spessore di compensazione * Shim *	spessore per vetro glass shim	guarnizione sotto vetro under glass gasket
Code		a	b	mm.	x	c	y	z	α	β
 PR2015	63	3	3	63	26**	2	AC2608	3 mm.	AC1020XL	GE1007TT
	65			65	24**	0				

F		Guarnizioni - gaskets		G						
fermavetro glazing bead	range vetro glass range	GU2035 2 mm + sigillatura + sealing	GP0095 3 mm 	spessore vetro glass thickness	asse fissaggio viti fermavetro securing axis for screws for the glazing beads	rientro fermavetro glazing beads gap	clips fissaggio fermavetro securing clips for glazing beads	spessore di compensazione * Shim *	spessore per vetro glass shim	guarnizione sotto vetro under glass gasket
Code		a	b	mm.	x	c	y	z	α	β
 PR2015	64	2	3	64	26**	2	AC2608	3 mm.	AC1020XL	GE1007TT
	66			66	24**	0				

*non fornito
*not included

** fissare tramite il primo foro della clip
** screw in the upper hole of the clip

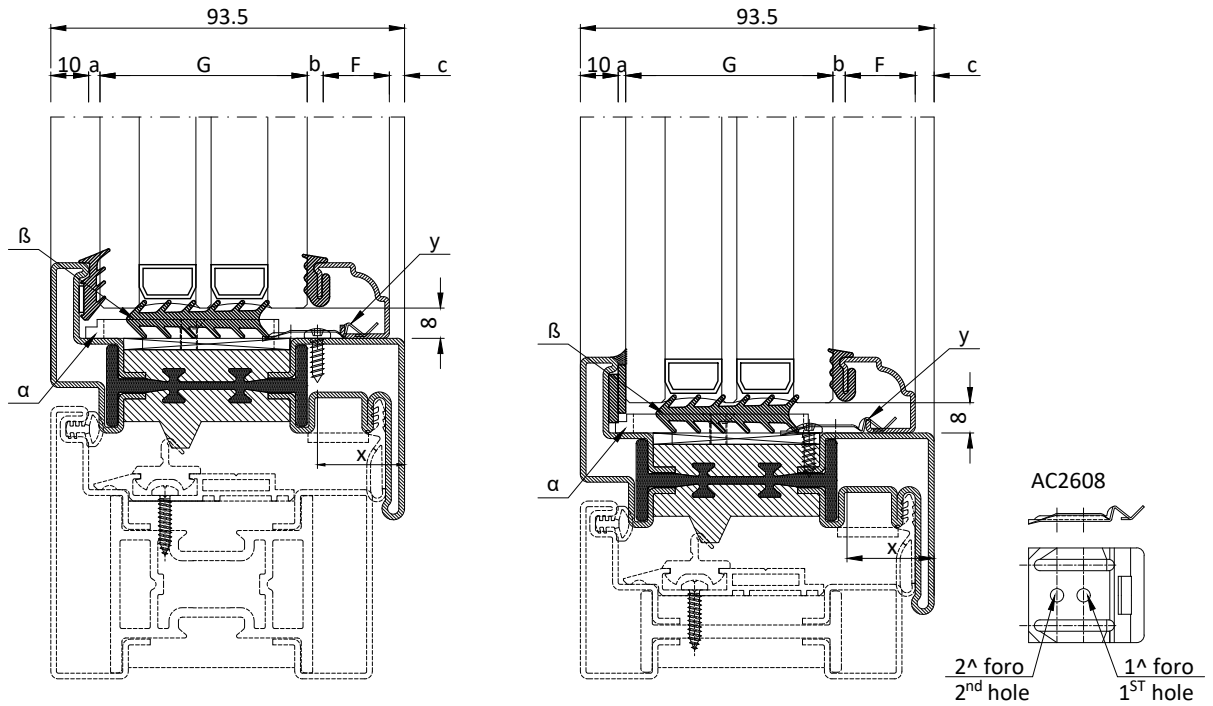

F		Guarnizioni - gaskets		G						
fermavetro glazing bead	range vetro glass range	GE1206 3 mm 	GE2028 2.5 mm 	spessore vetro glass thickness	asse fissaggio viti fermavetro securing axis for screws for the glazing beads	rientro fermavetro glazing beads gap	clips fissaggio fermavetro securing clips for glazing beads	spessore di compensazione * Shim *	spessore per vetro glass shim	guarnizione sotto vetro under glass gasket
Code		a	b	mm.	x	c	y	z	α	β
 PR2028	52	3	2.5	52	34	6	AC2608	3 mm.	AC1020XL	GE1007TT
	58			54	25**	4				
				56	23**	2				
				58	21**	0				

F		Guarnizioni - gaskets		G						
fermavetro glazing bead	range vetro glass range	GU2035 2 mm + sigillatura + sealing	GE2028 2.5 mm 	spessore vetro glass thickness	asse fissaggio viti fermavetro securing axis for screws for the glazing beads	rientro fermavetro glazing beads gap	clips fissaggio fermavetro securing clips for glazing beads	spessore di compensazione * Shim *	spessore per vetro glass shim	guarnizione sotto vetro under glass gasket
Code		a	b	mm.	x	c	y	z	α	β
 PR2028	53	2	2.5	53	34	6	AC2608	3 mm.	AC1020XL	GE1007TT
	59			55	25**	4				
				57	23**	2				
				59	21**	0				

*non fornito
*not included

** fissare tramite il primo foro della clip
** screw in the upper hole of the clip

Taglio a 45° dei fermavetri effettuabile utilizzando la ganascia AT2029
45° cutting of the glazing beads done using the cutting jaw AT2029



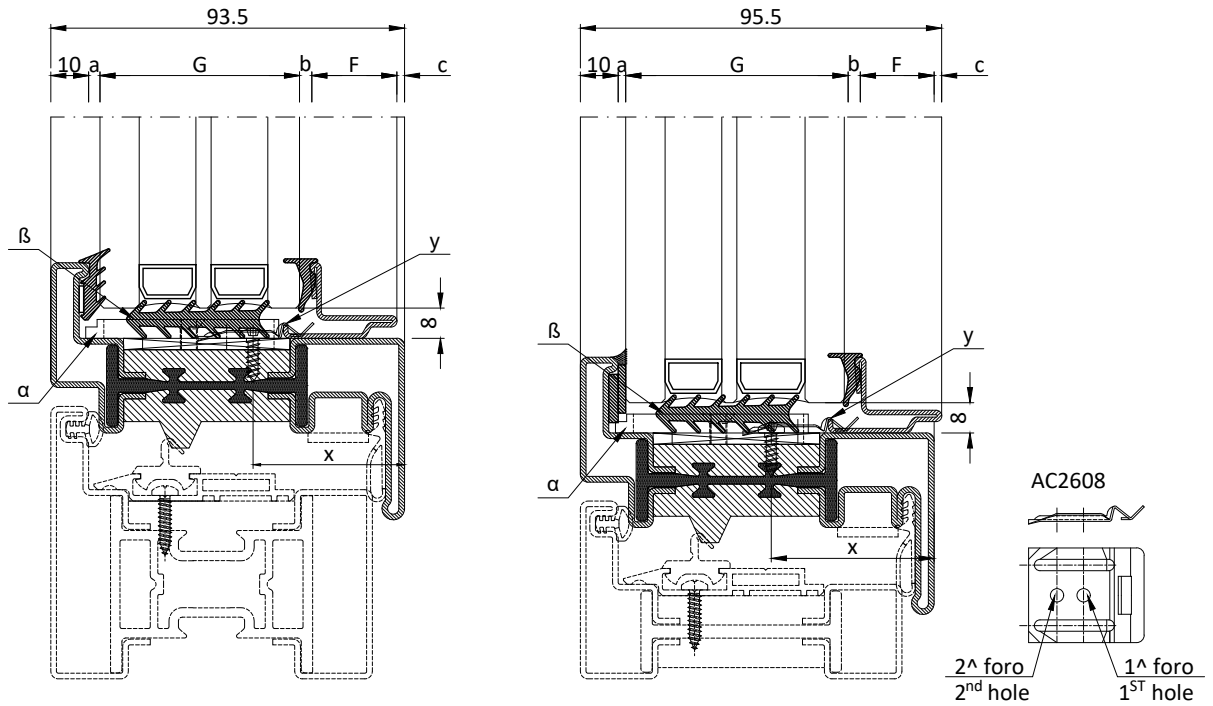

F		Guarnizioni - gaskets		G						
fermavetro glazing bead	range vetro glass range	GE1206 3 mm 	GP0095 3 mm 	spessore vetro glass thickness	asse fissaggio viti fermavetro securing axis for screws for the glazing beads	rientro fermavetro glazing beads gap	clips fissaggio fermavetro securing clips for glazing beads	spessore di compensazione * Shim *	spessore per vetro glass shim	guarnizione sotto vetro under glass gasket
Code		a	b	mm.	x	c	y	z	α	β
 PR2038	52	3	3	52	40**	2	AC2608	3 mm.	AC1020XL	GE1007TT
	58			54	38**	0				
				56	43	-2				
				58	41	-4				

F		Guarnizioni - gaskets		G						
fermavetro glazing bead	range vetro glass range	GU2035 2 mm + sigillatura + sealing	GP0095 3 mm 	spessore vetro glass thickness	asse fissaggio viti fermavetro securing axis for screws for the glazing beads	rientro fermavetro glazing beads gap	clips fissaggio fermavetro securing clips for glazing beads	spessore di compensazione * Shim *	spessore per vetro glass shim	guarnizione sotto vetro under glass gasket
Code		a	b	mm.	x	c	y	z	α	β
 PR2038	53	2	3	53	40**	2	AC2608	3 mm.	AC1020XL	GE1007TT
	59			55	38**	0				
				57	36	-2				
				59	34	-4				

*non fornito
*not included

** fissare tramite il primo foro della clip
** screw in the upper hole of the clip

Taglio a 45° dei fermavetri effettuabile utilizzando la ganascia AT2038
45° cutting of the glazing beads done using the cutting jaw AT2038



PR2015 - PR2028 - PR2038

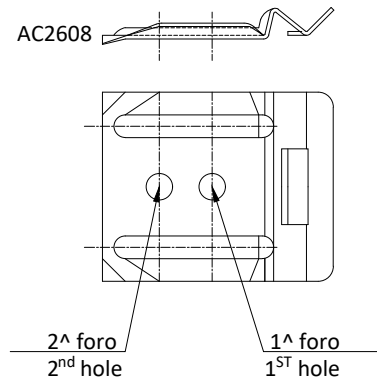
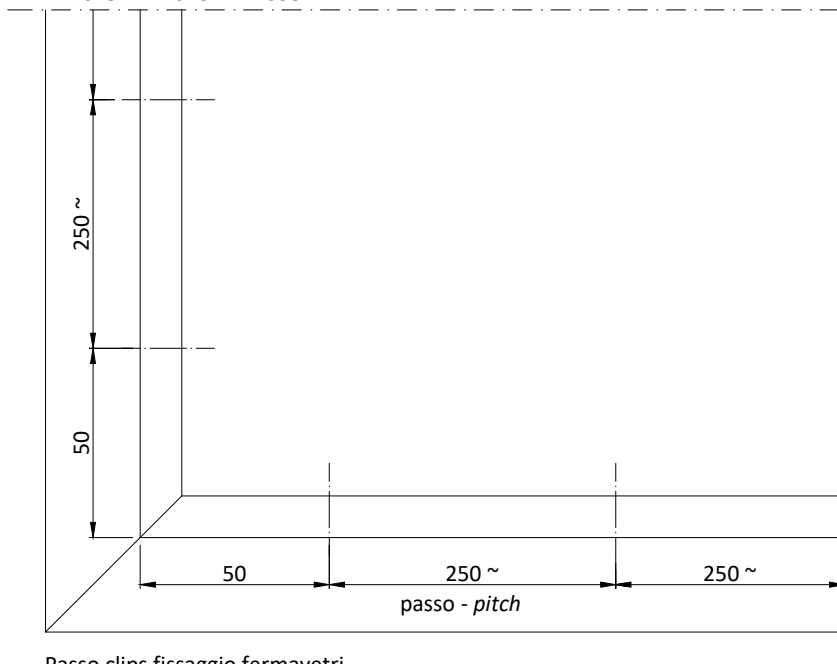

Passo clips fissaggio fermavetri
Clip pitch for fixing the glazing beads

Per il fissaggio utilizzare TCTC 3.5 x 9.5
For fixing use TCTC 3.5 x 9.5 screws

Fori eseguibili con maschera AT2828
Holes to be done with AT2828

PR2007 - PR1007 - PR2008 - PR2009

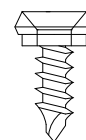
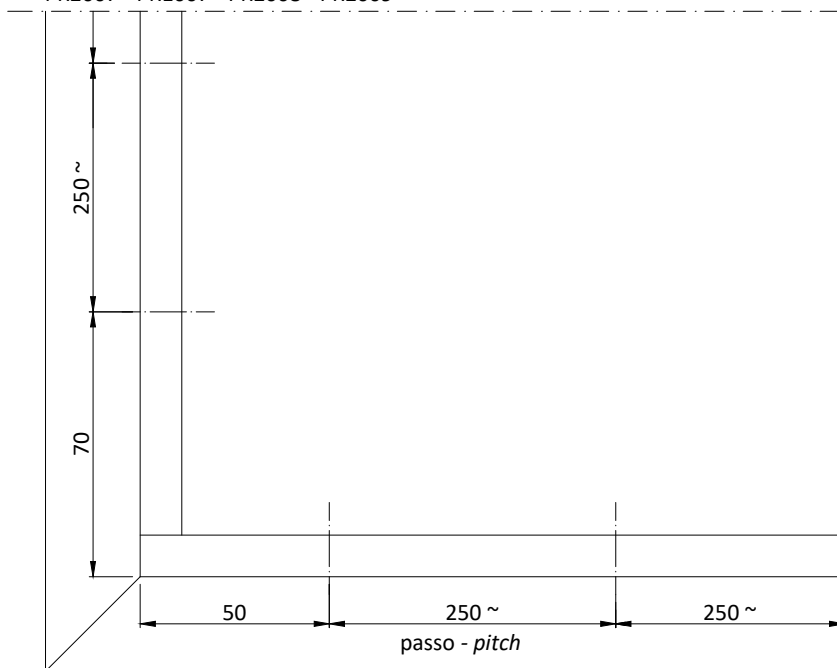

CV5001 + CV5012
CV5001I + CV5012I

Passo vite e boccola fissaggio fermavetri
Clip pitch to fix glazing beads

Fori eseguibili con maschera AT1234
Holes to be done with AT1234

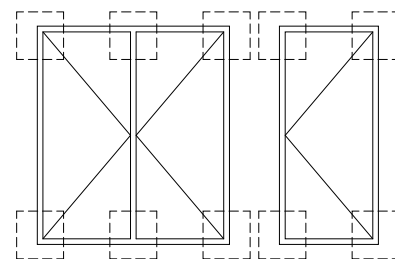

Acciaio zincato - Acciaio Corten - Acciaio inox
Saldare in continuo le superfici di contatto indicate

Galvanised steel - Cor-ten steel - Stainless steel
Seam-weld the shown areas

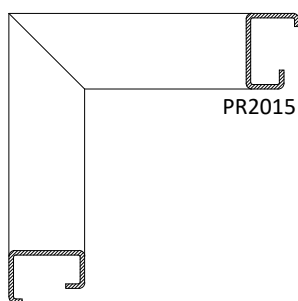
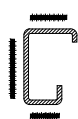

PR2015

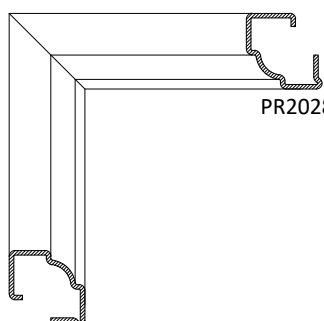
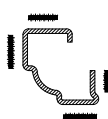

PR2028

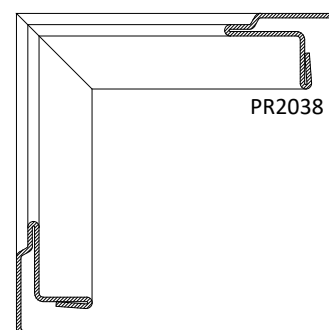
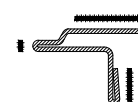

PR2038

Ottone
Saldare a TIG a punti le zone indicate.

Brass
Spot weld (TIG) the marked areas.

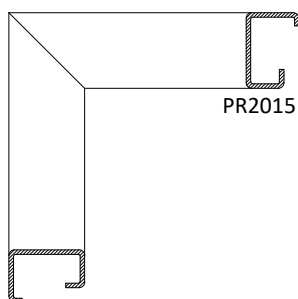
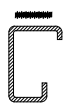

PR2015

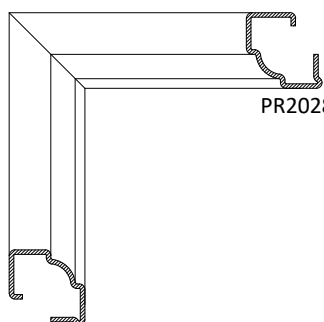
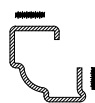

PR2028

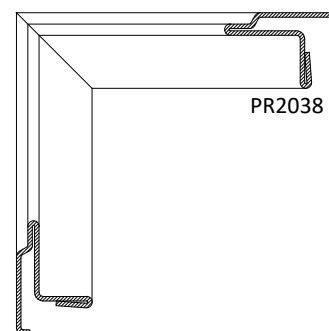
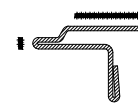

PR2038

PR2028
Taglio a 45° dei fermavetri effettuabile utilizzando la ganascia AT2029
45° cutting of the glazing beads done using the cutting jaw AT2029

PR2038
Taglio a 45° dei fermavetri effettuabile utilizzando la ganascia AT2038
45° cutting of the glazing beads done using the cutting jaw AT2038

PARTICOLARE "A" _ DETAIL "A"

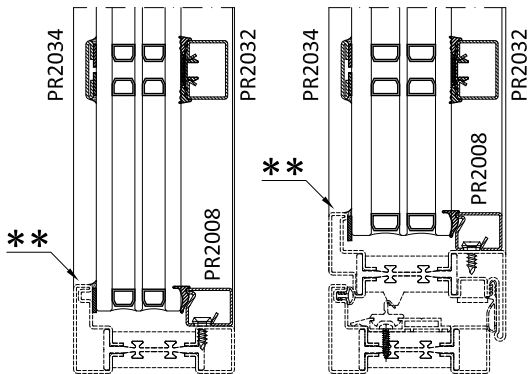
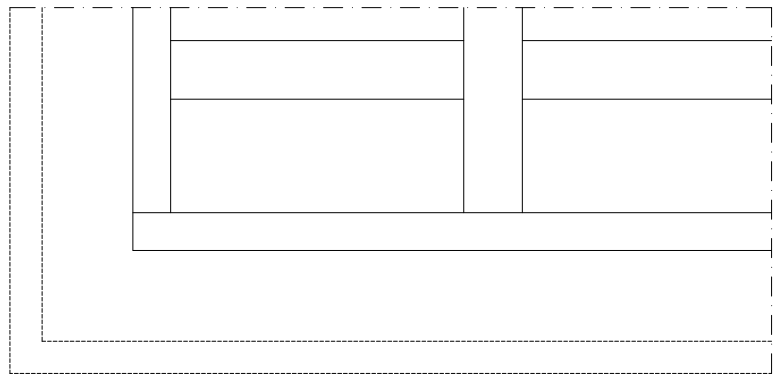
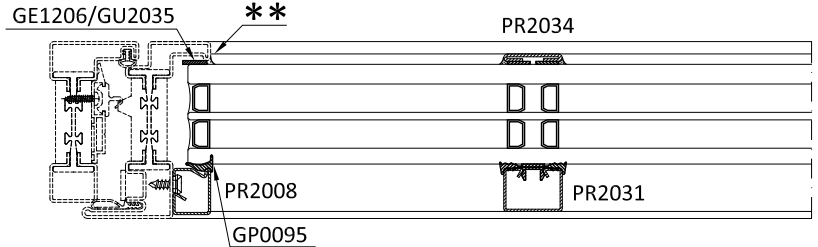
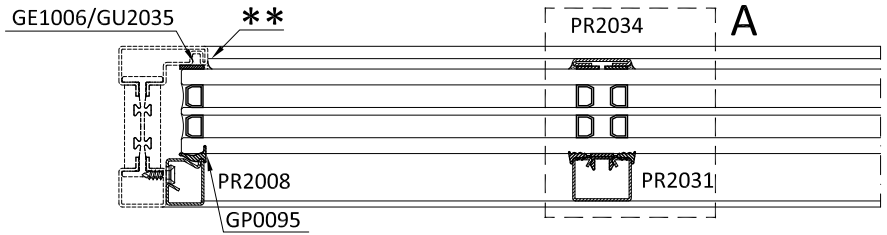
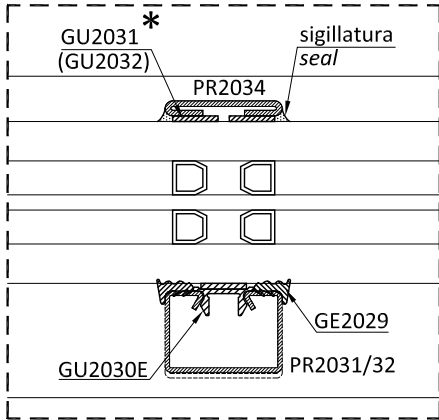

PARTICOLARE "B" _ DETAIL "B"

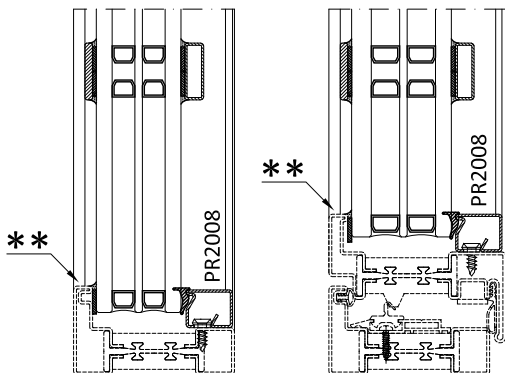
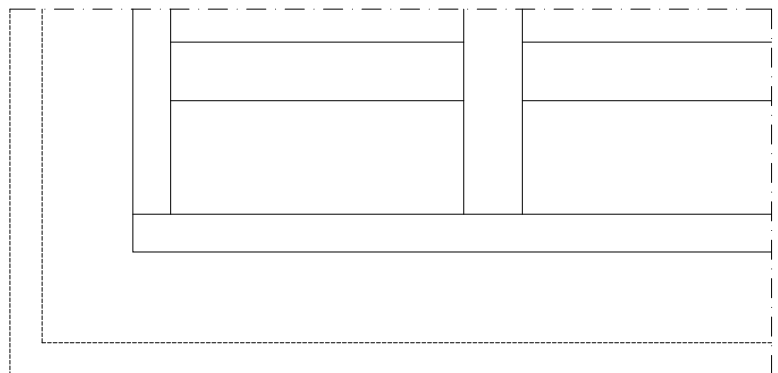
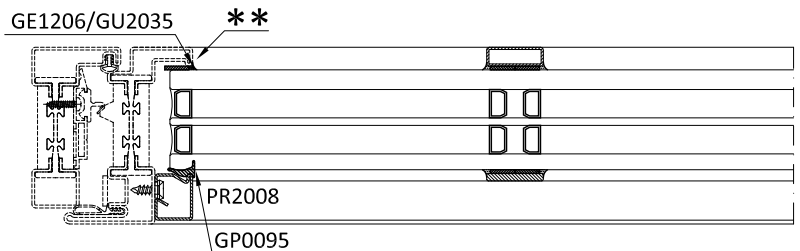
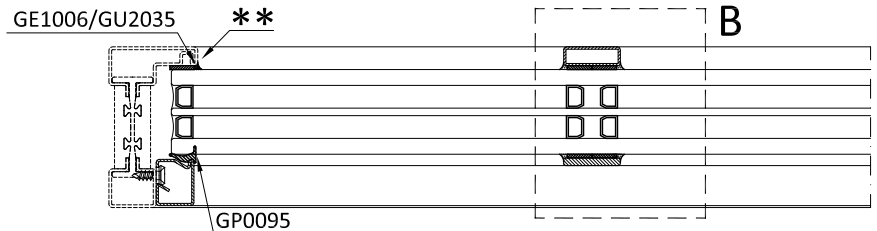
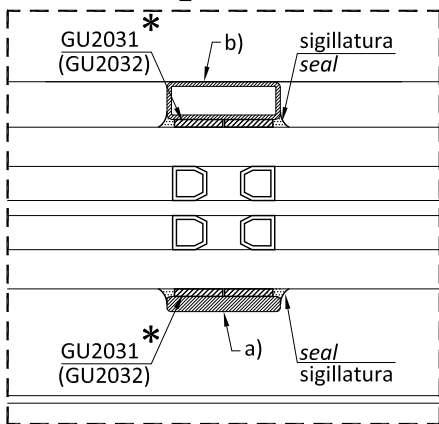

* Per utilizzo dividivetro SOLO orizzontali o SOLO verticali GU2031
 Per utilizzo dividivetro orizzontali e verticali GU2031 verticalmente GU2032 orizzontalmente
 For ONLY horizontal or ONLY vertical glazing beads use GU2031
 For horizontal and vertical glazing beads use GU2031 vertically and GU2032 horizontally

** Saldare o sigillare
 Weld or seal

a) profilo commerciale | section profile 30x4 mm
 b) profilo commerciale | section profile 30x10 mm

PARTICOLARE "C" _ DETAIL "C"

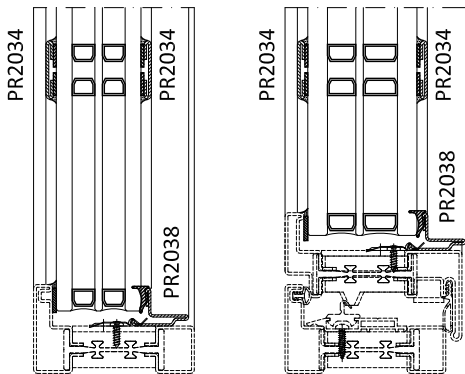
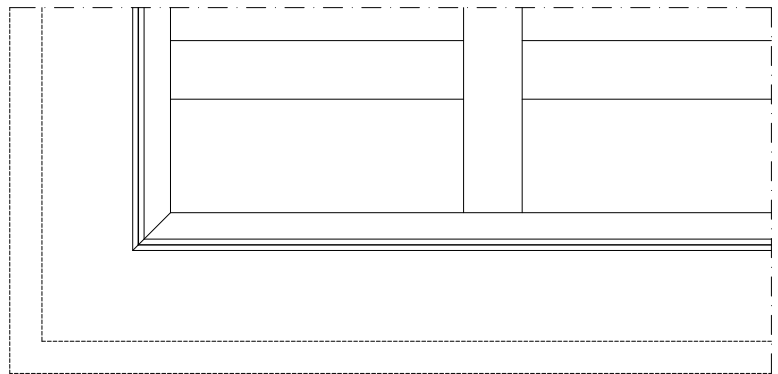
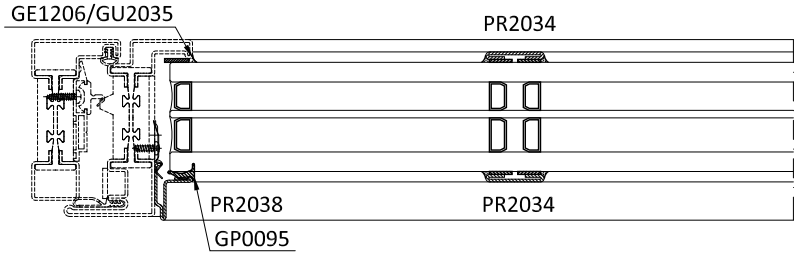
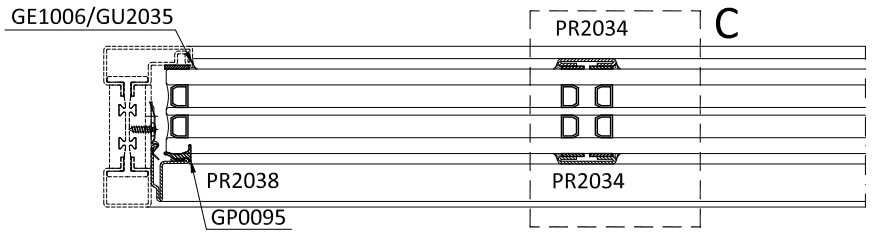
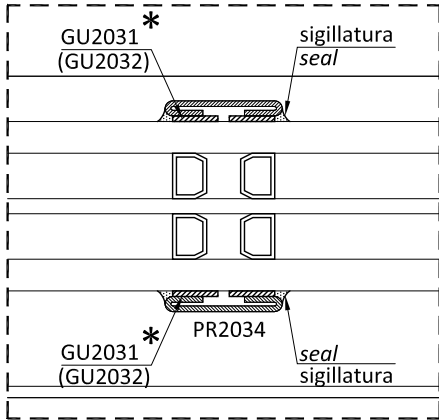

PARTICOLARE "D" _ DETAIL "D"

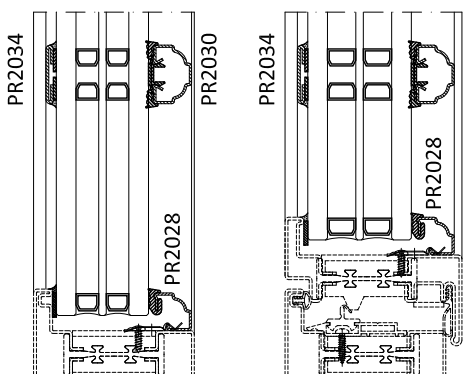
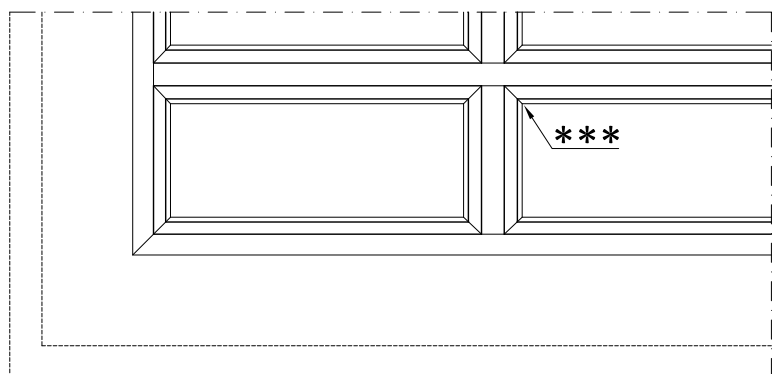
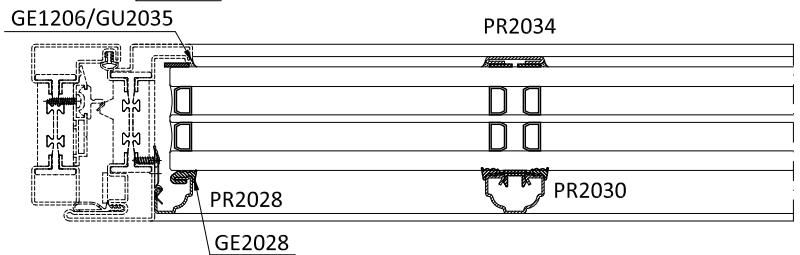
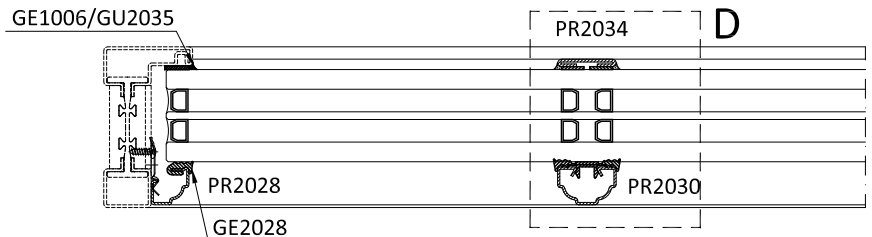
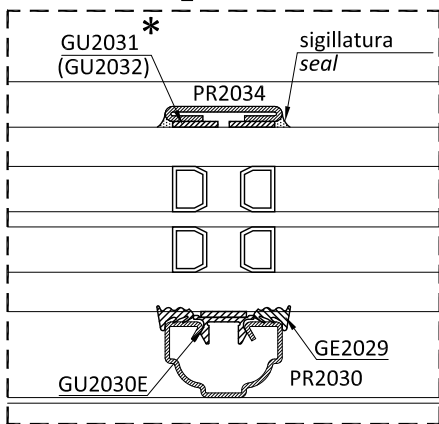

* Per utilizzo dividivetro SOLO orizzontali o SOLO verticali GU2031
 Per utilizzo dividivetro orizzontali e verticali GU2031 verticalmente GU2032 orizzontalmente
 For ONLY horizontal or ONLY vertical glazing beads use GU2031
 For horizontal and vertical glazing beads use GU2031 vertically and GU2032 horizontally

** Saldare o sigillare
 Weld or seal

*** Lavorazione di intestatura effettuabile con stampo AT2030
 Processing of butt jointing carried out with a mould

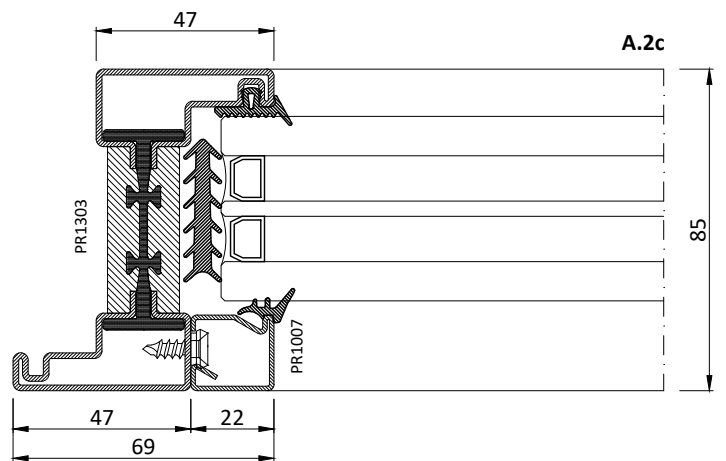
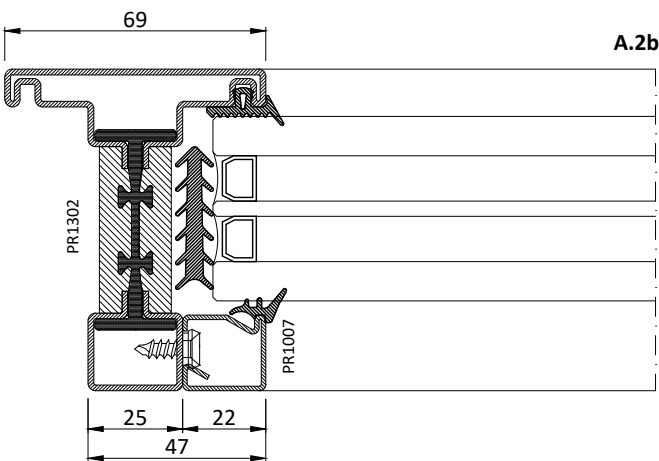
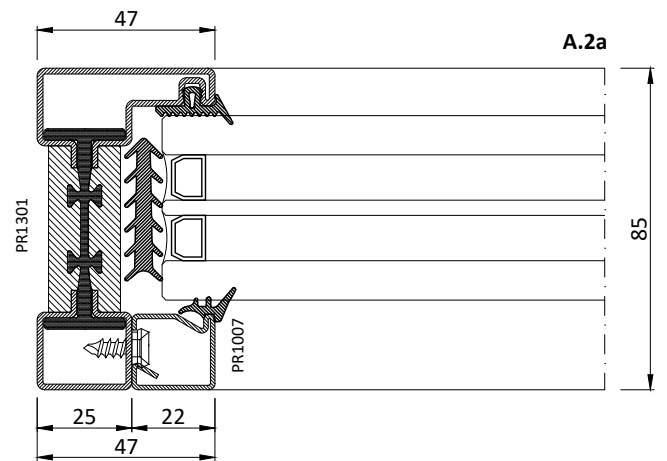
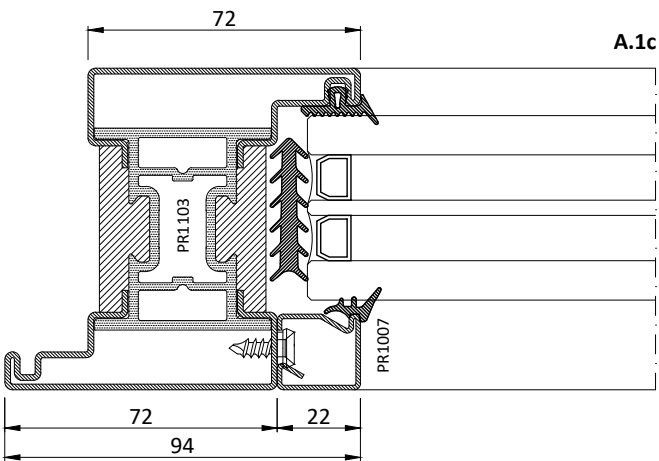
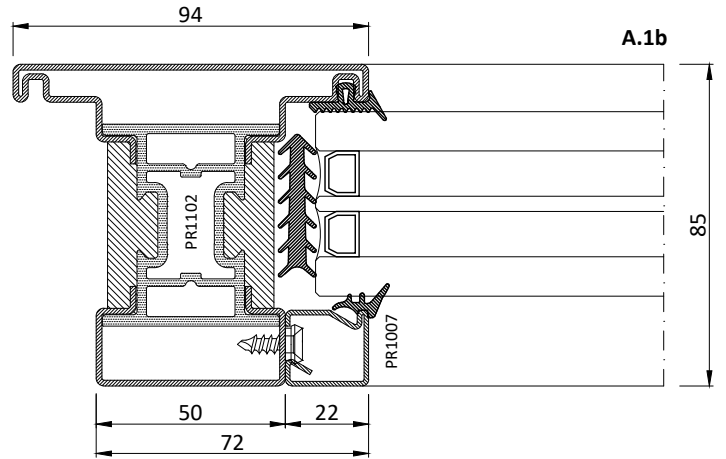
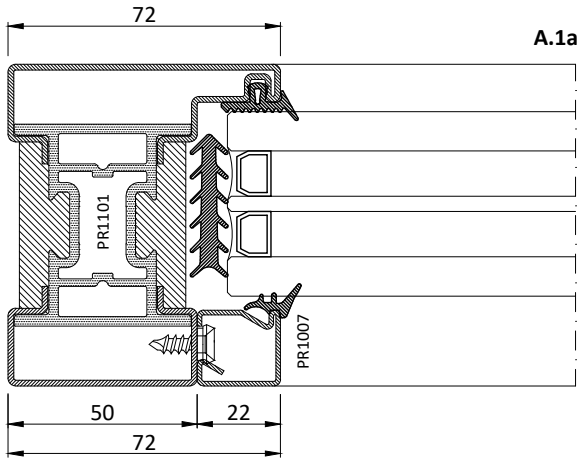
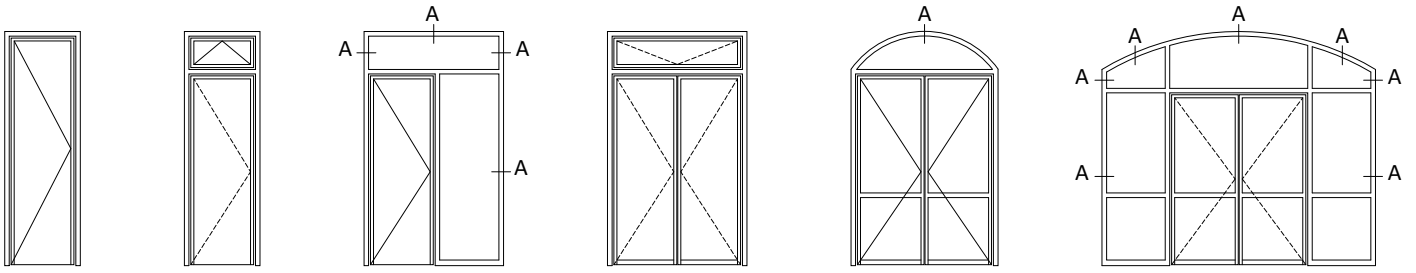

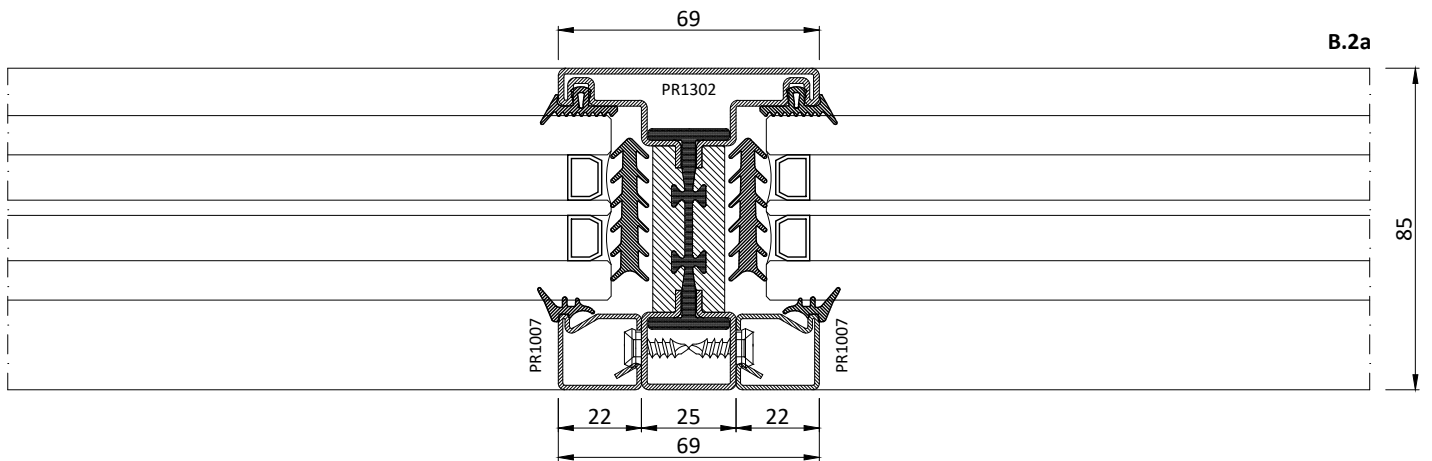
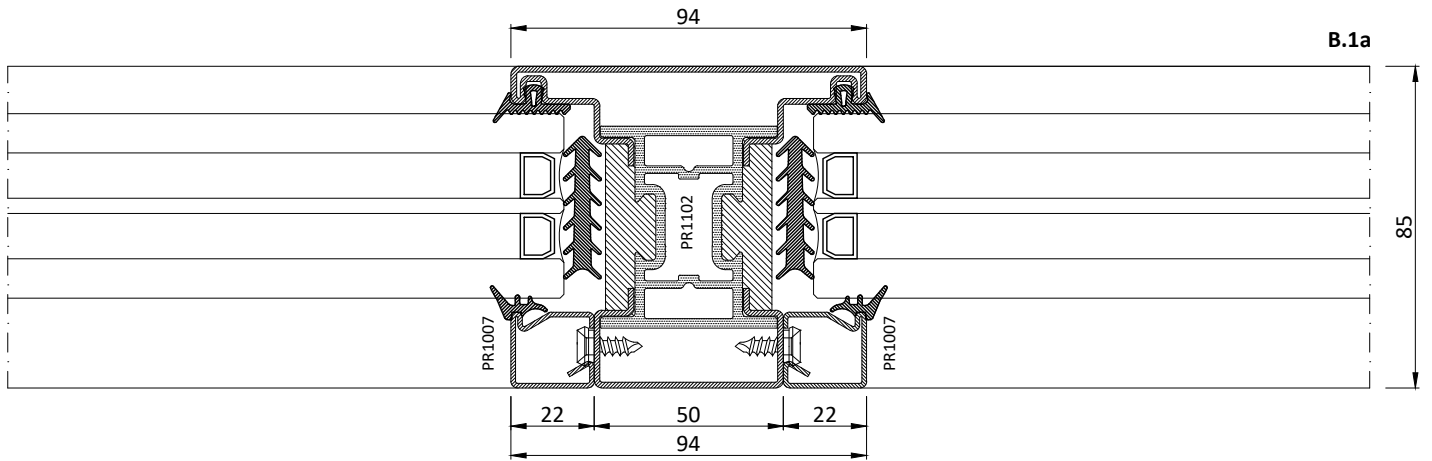
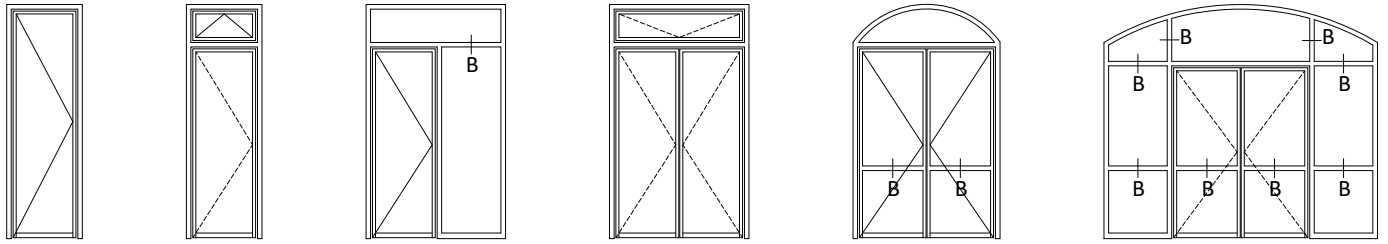

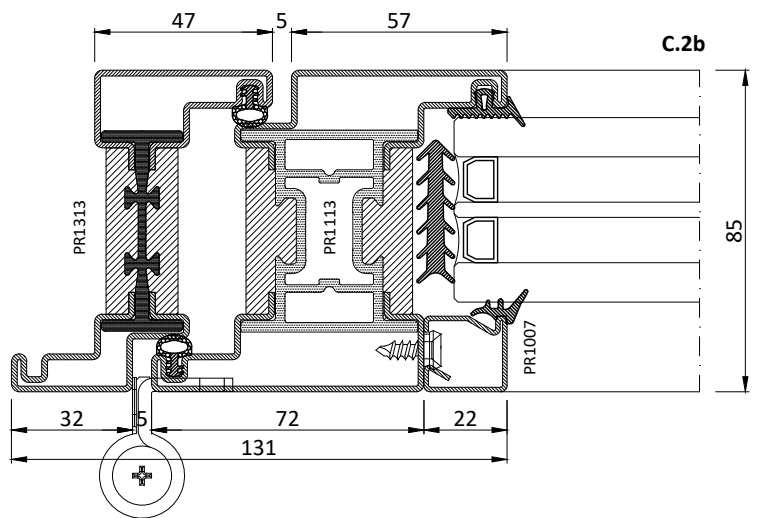
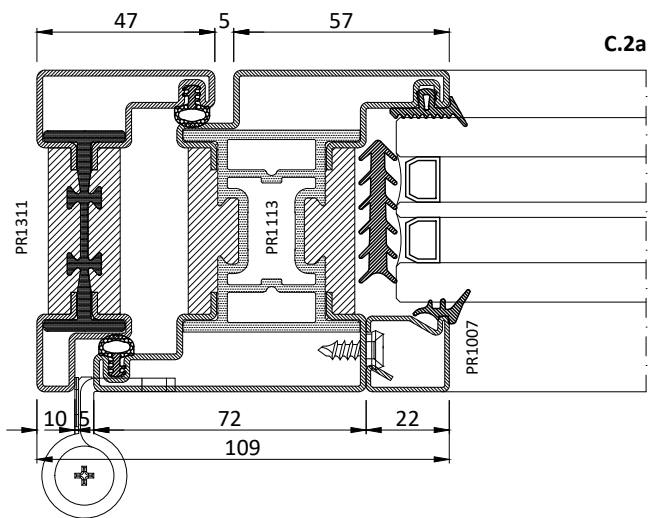
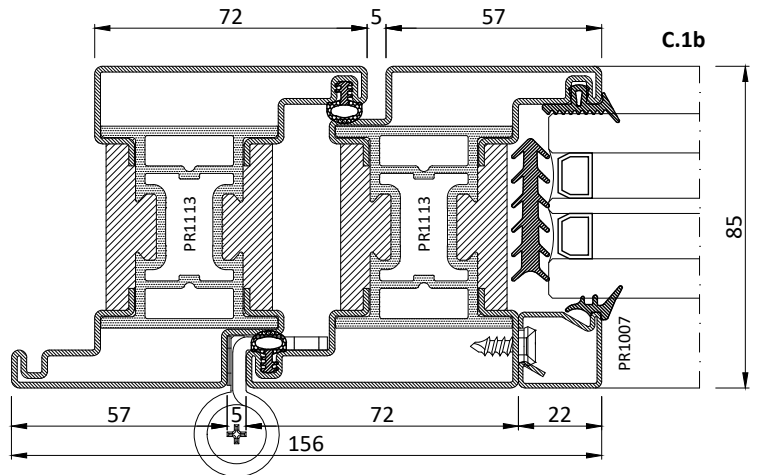
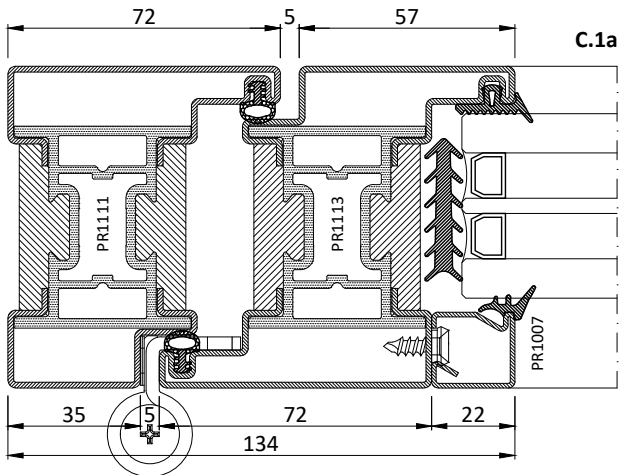
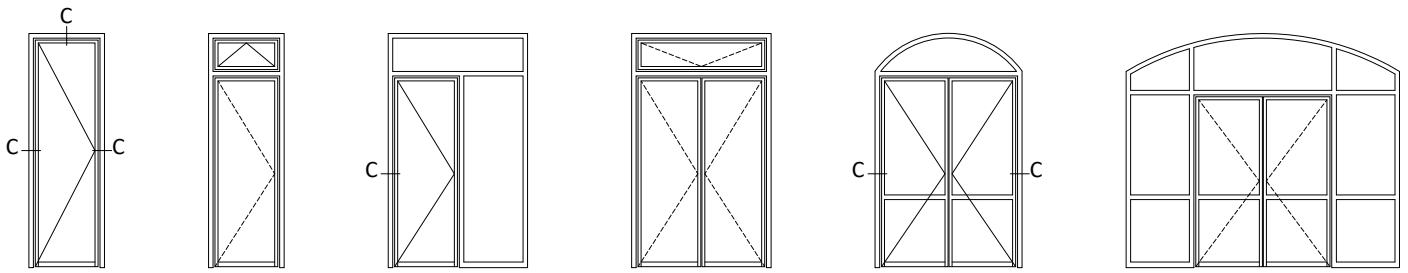

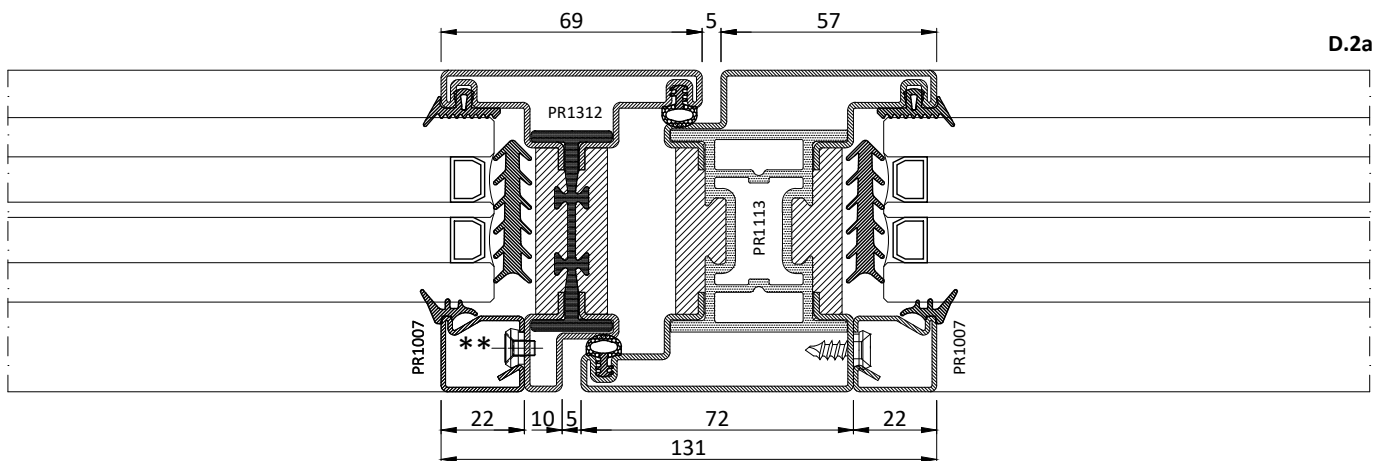
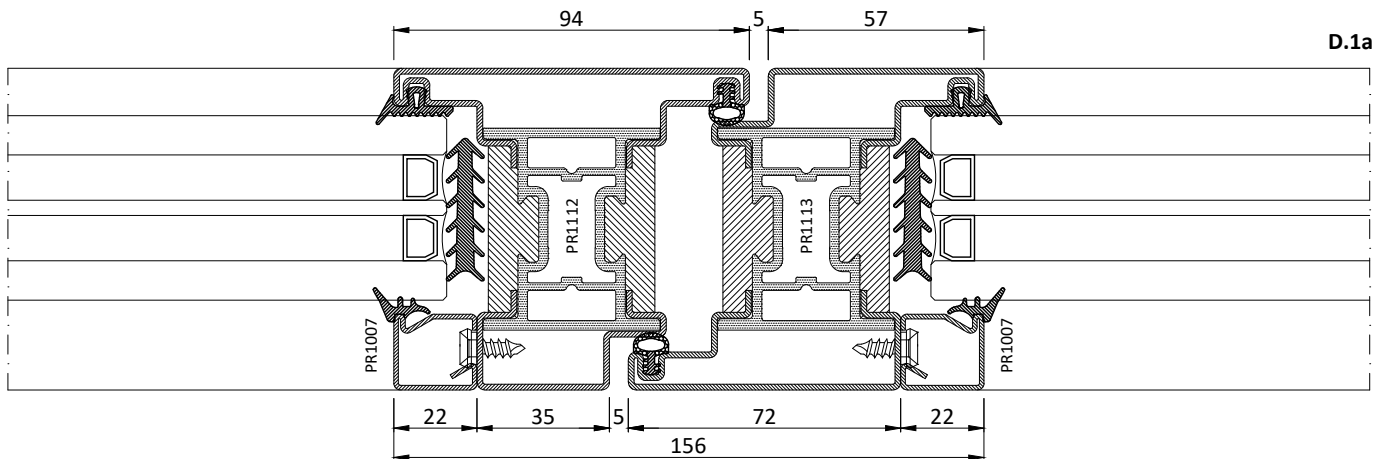
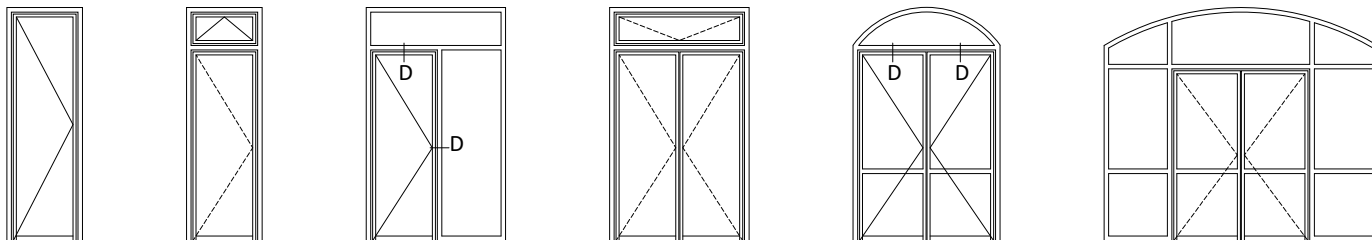

** Utilizzare vite CV1243
** Please use screw CV1243

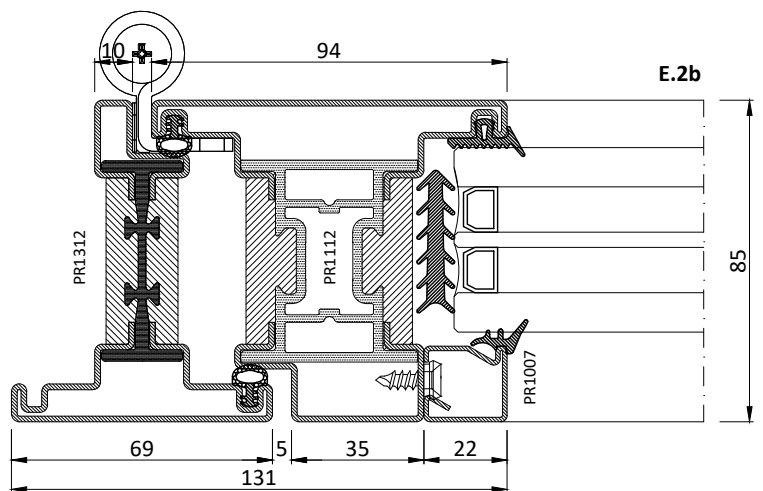
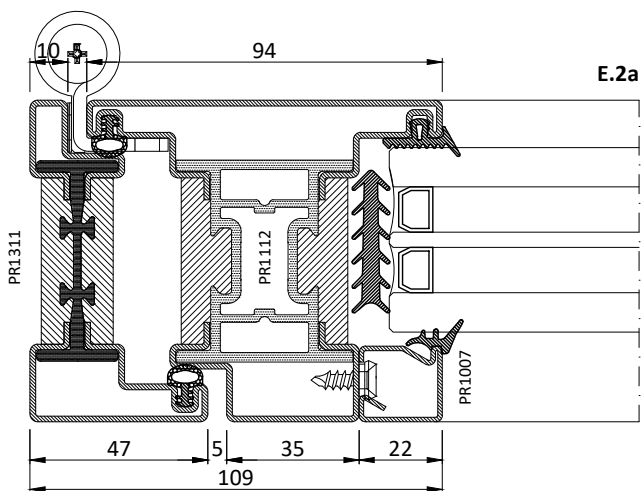
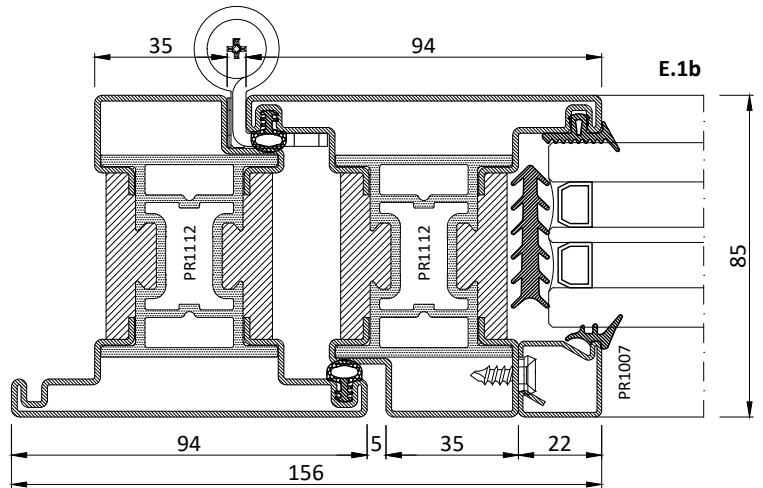
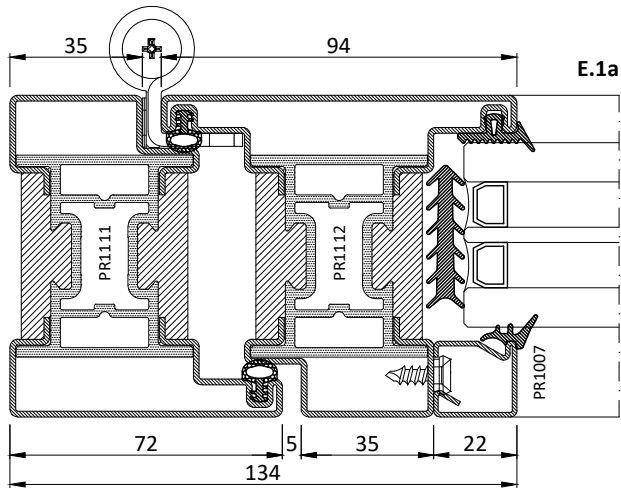
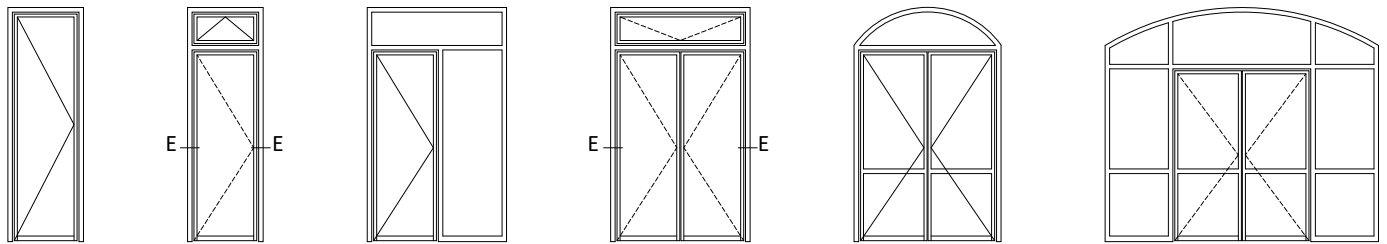

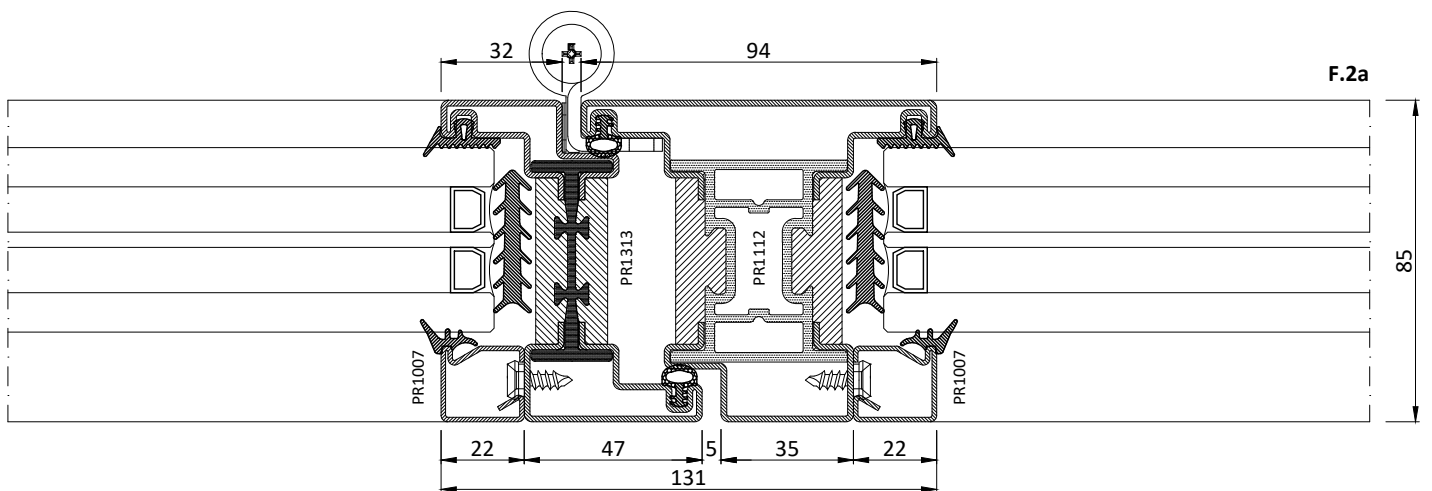
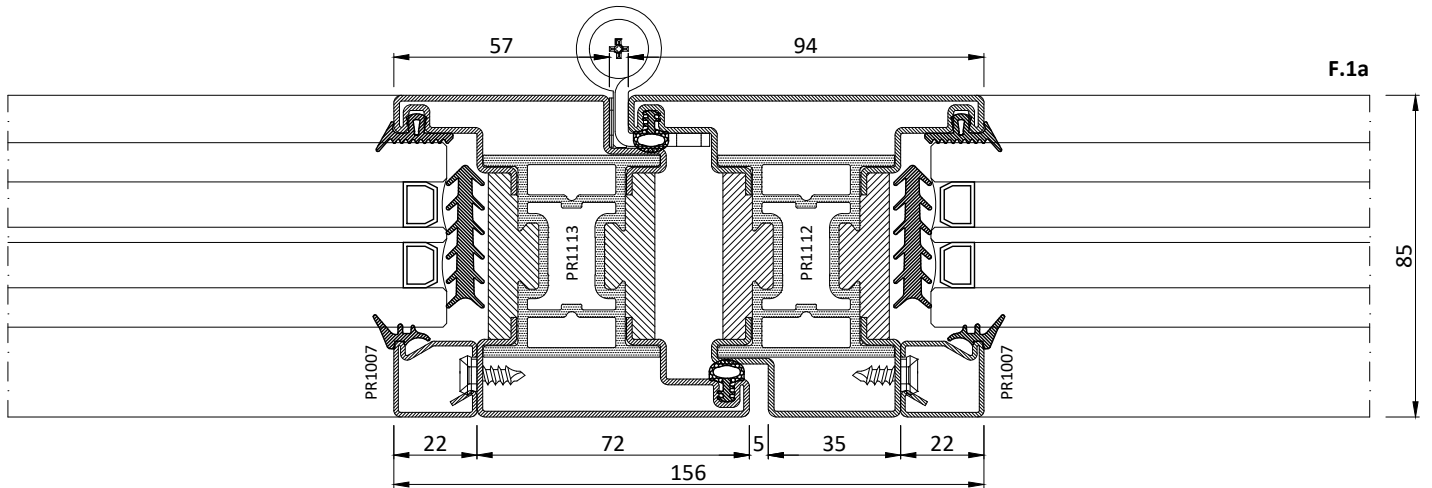
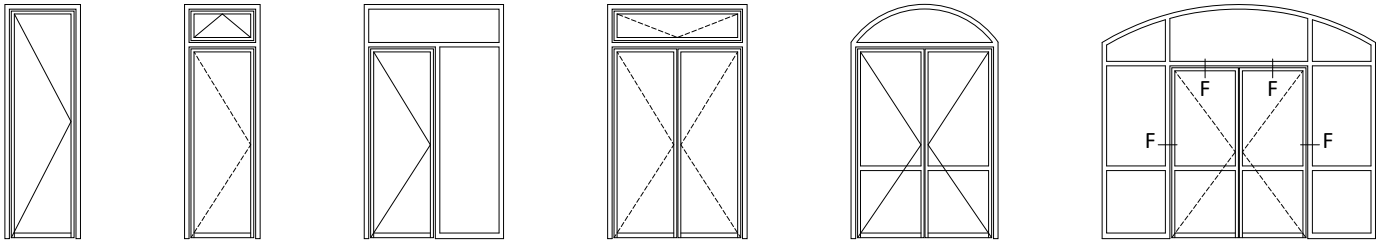

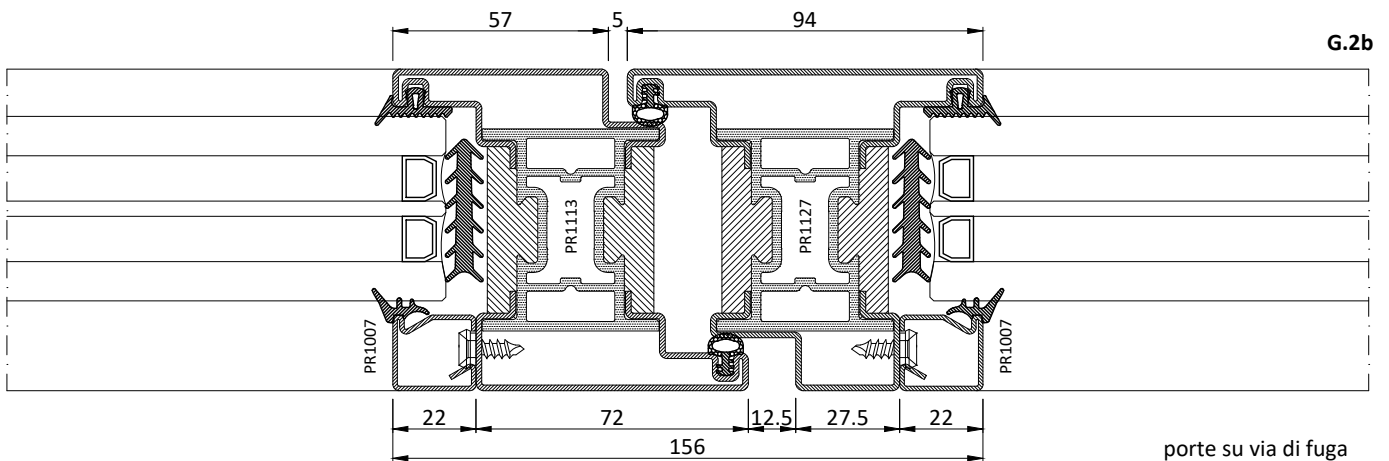
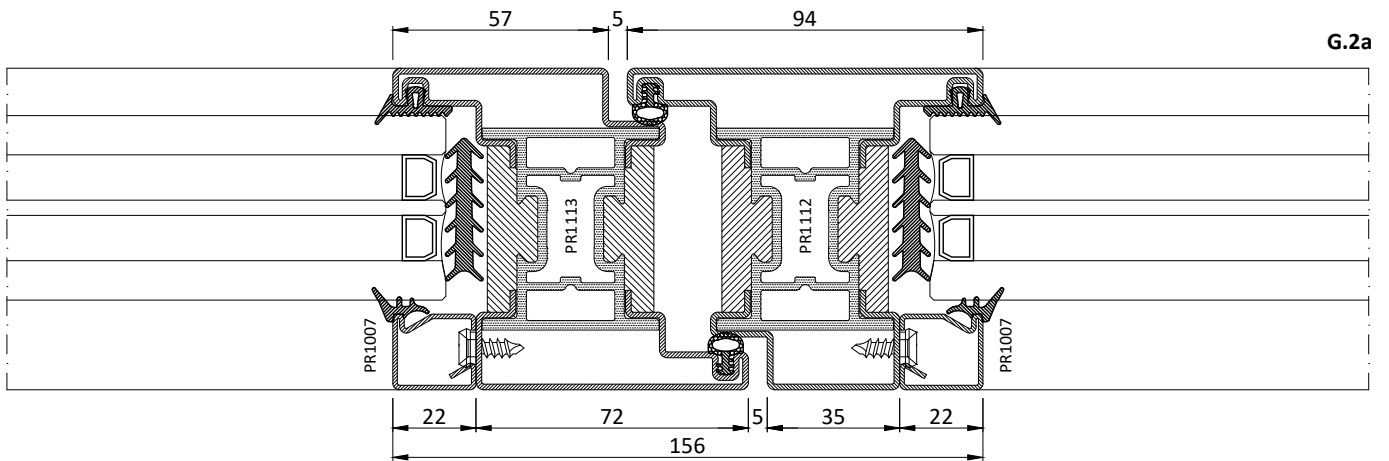
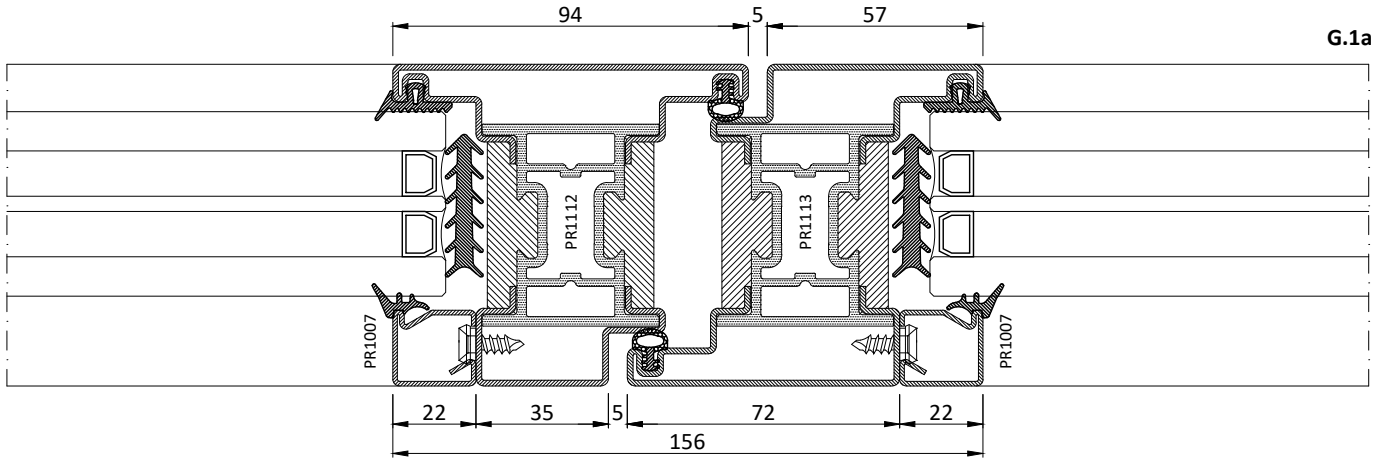
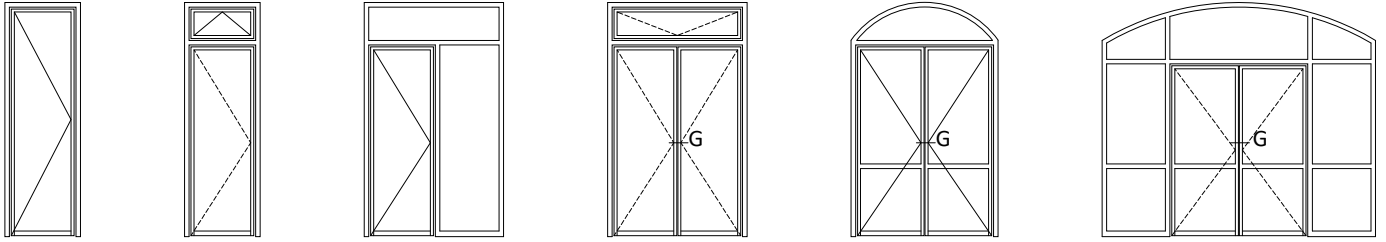

porte su via di fuga
Escape route door

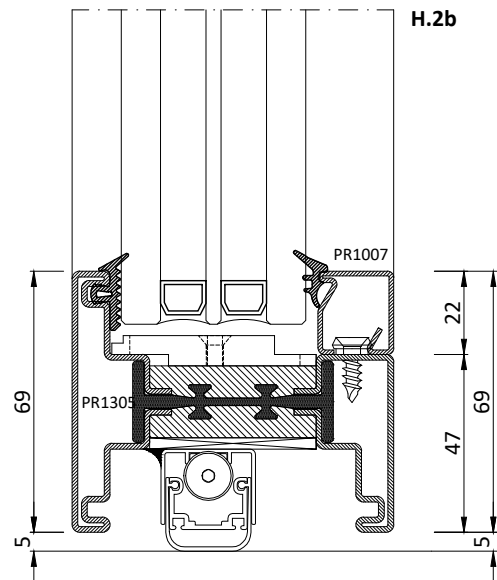
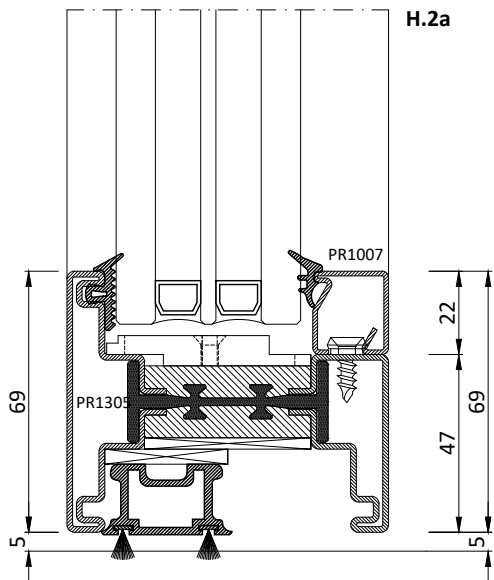
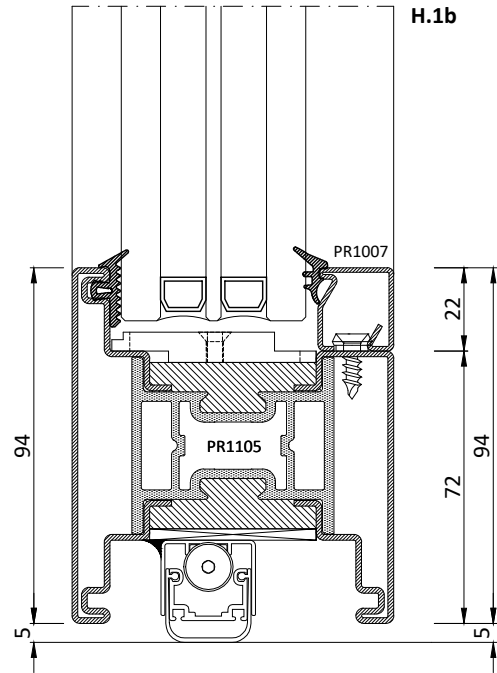
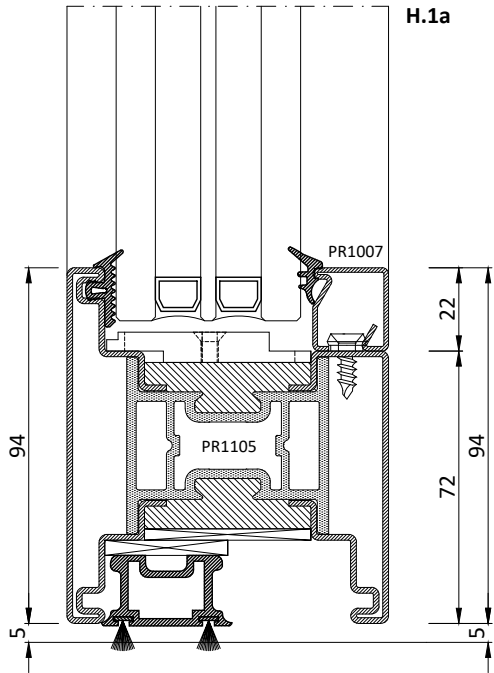
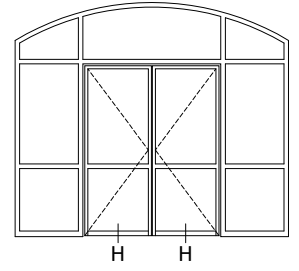
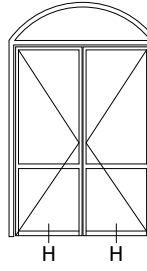
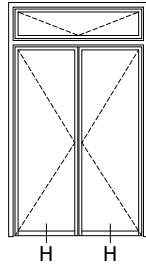
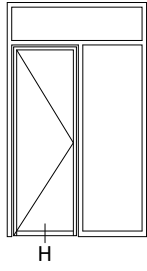
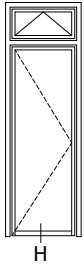
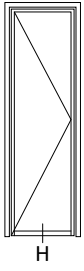

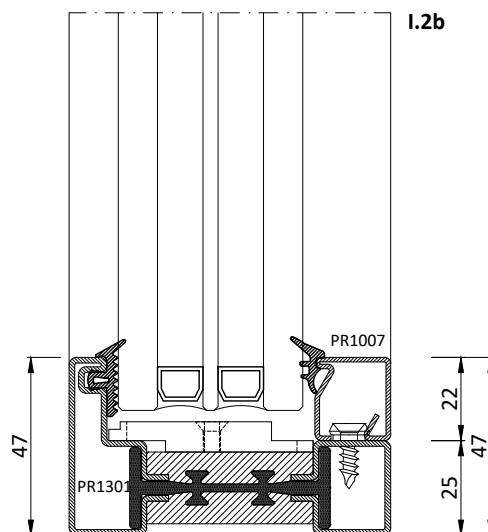
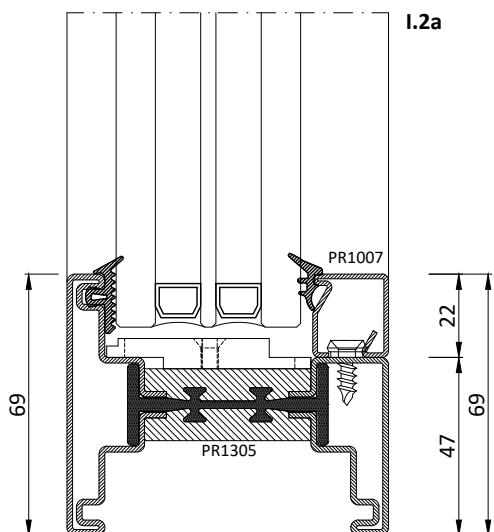
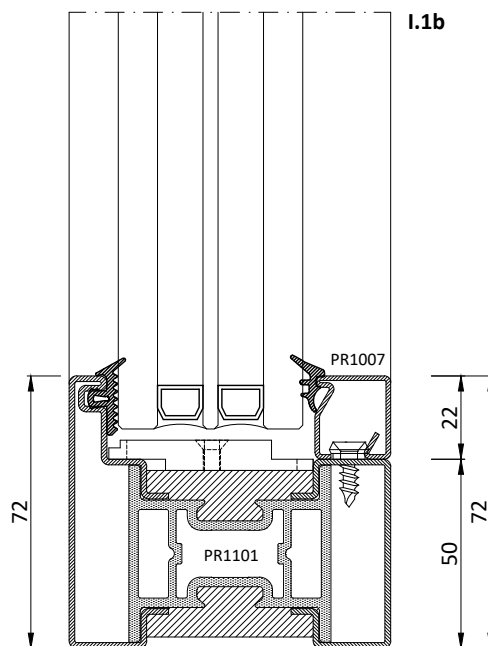
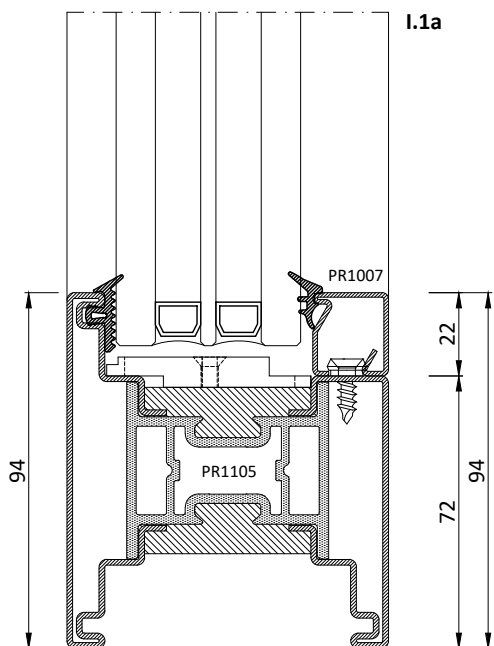
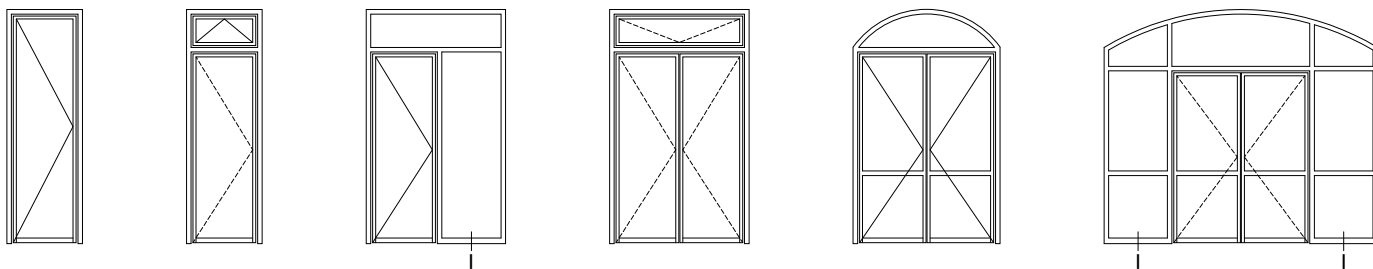

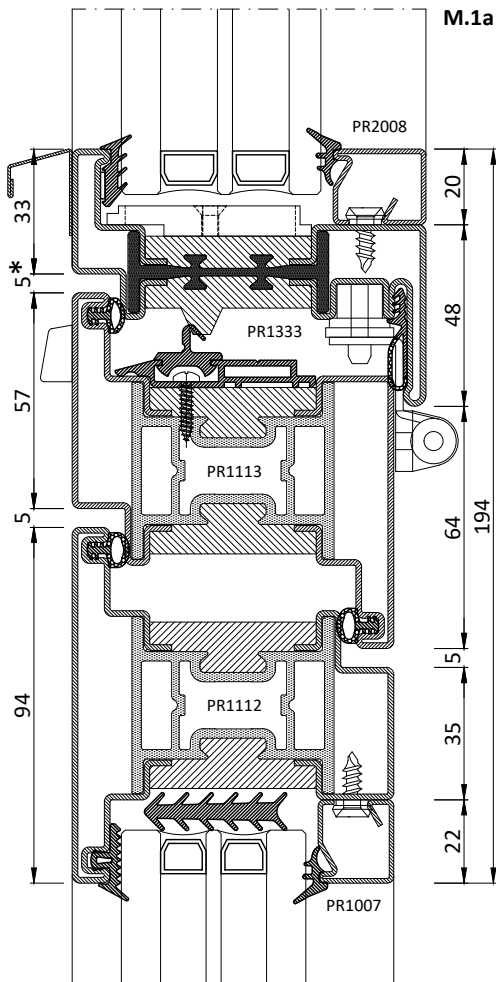
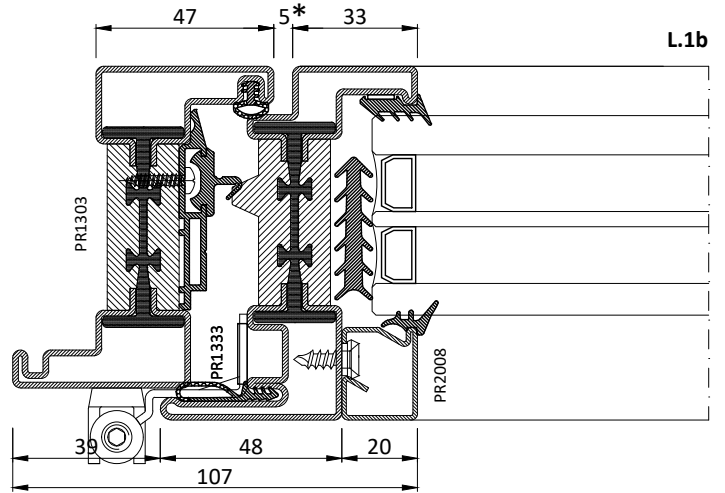
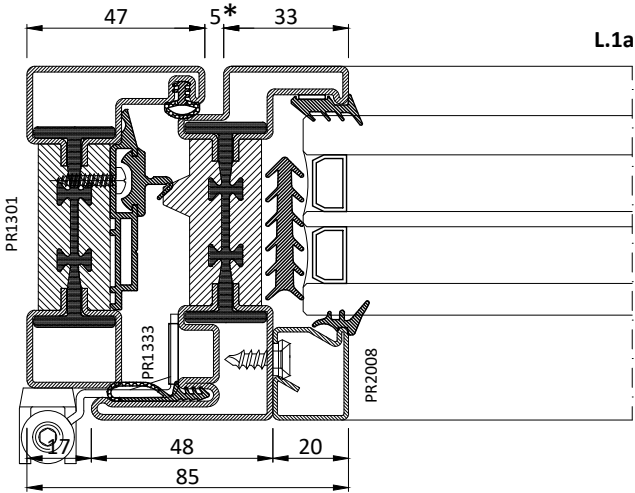
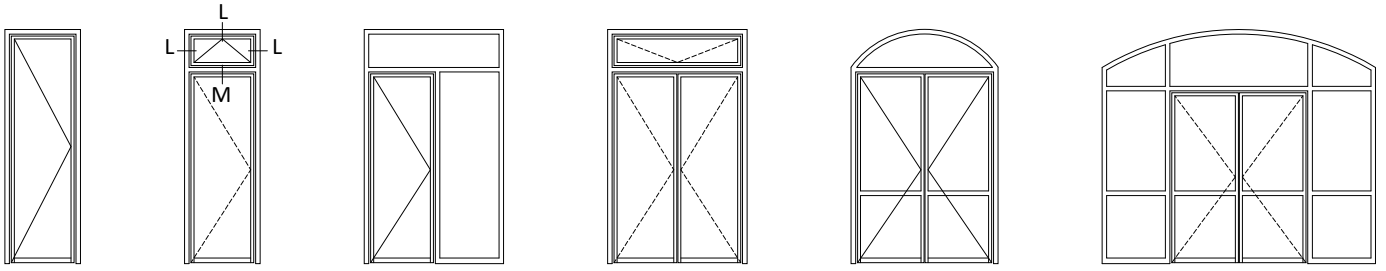

* Vedi tabella 4.1.5
* See chart 4.1.5

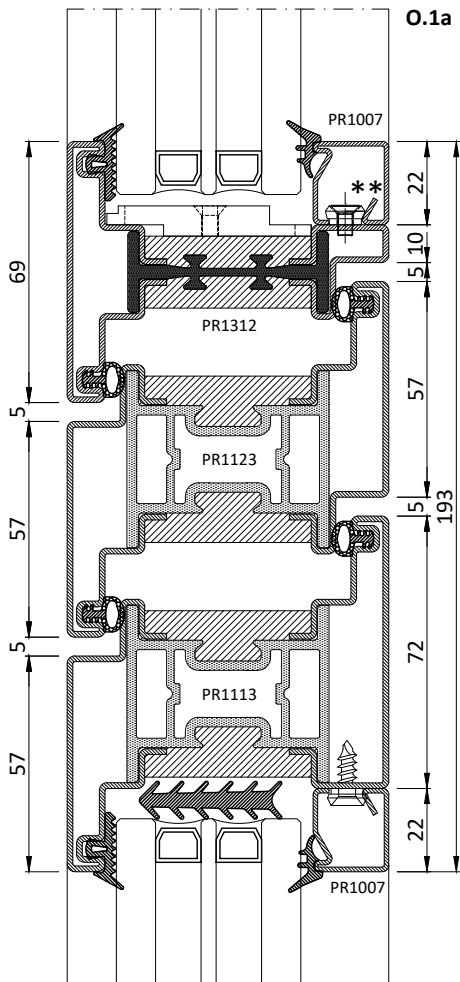
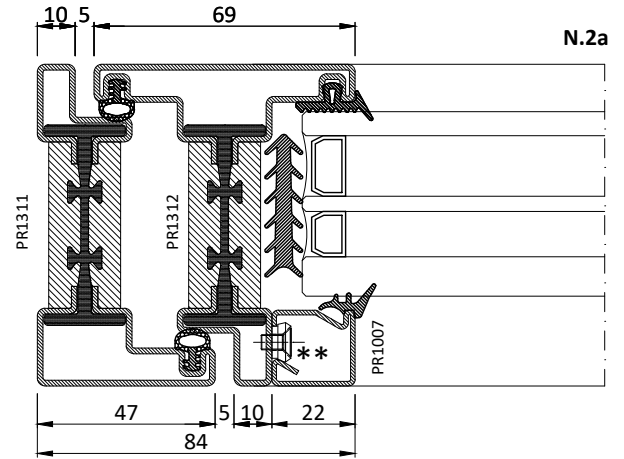
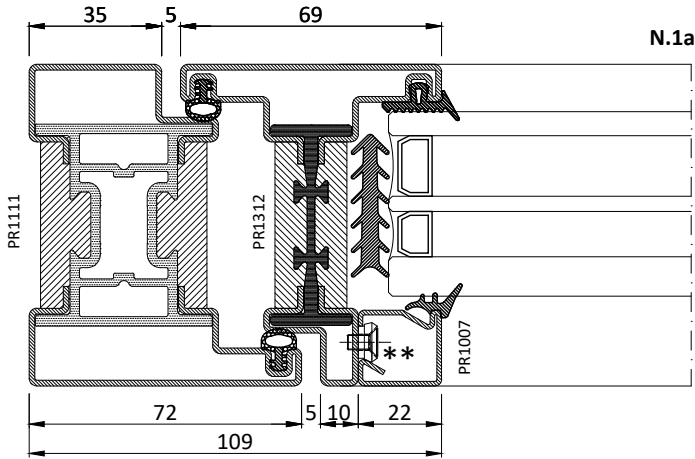
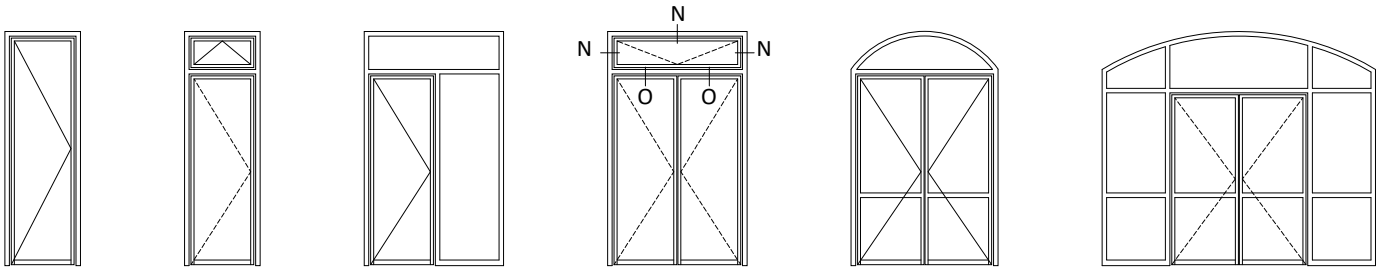

** Utilizzare vite CV1243
** Please use screw CV1243

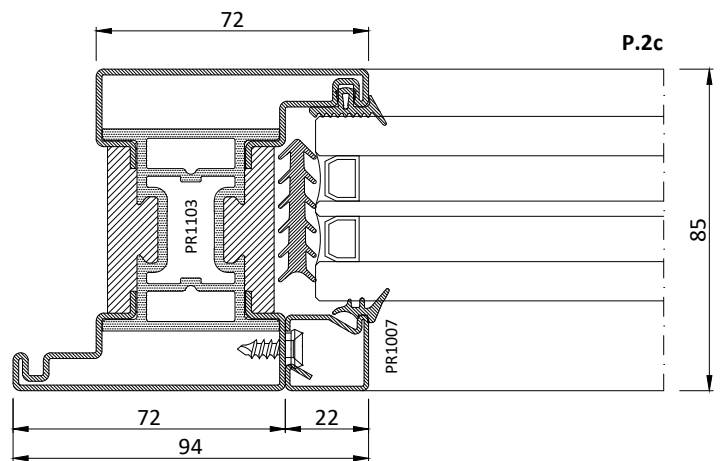
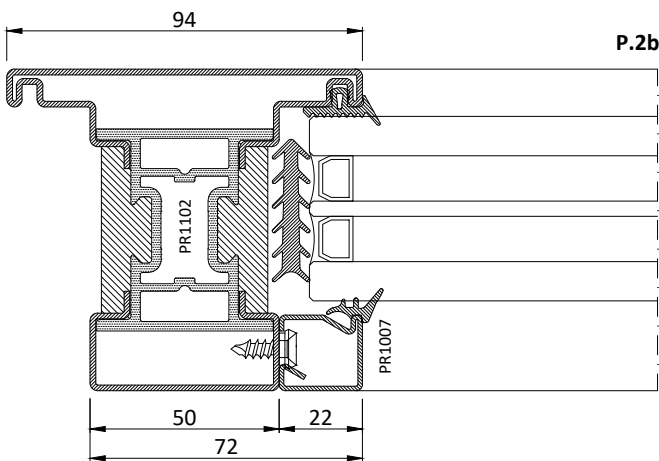
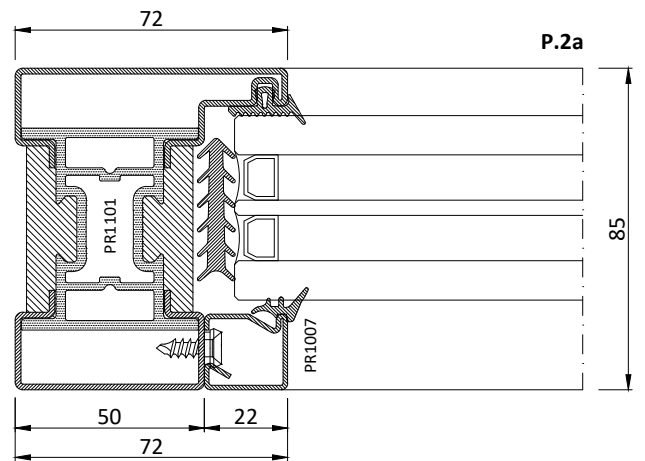
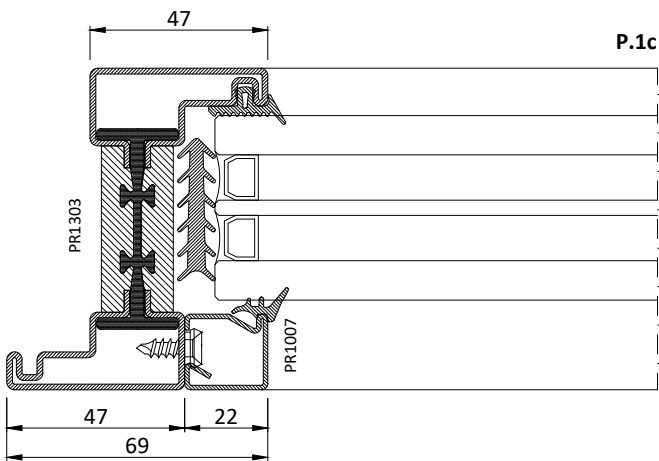
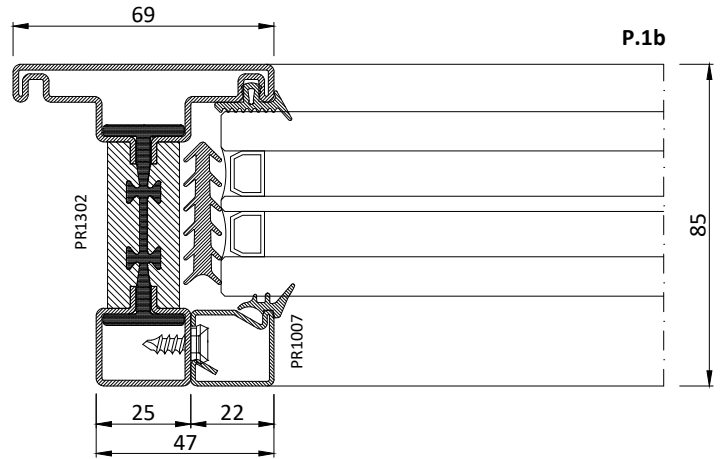
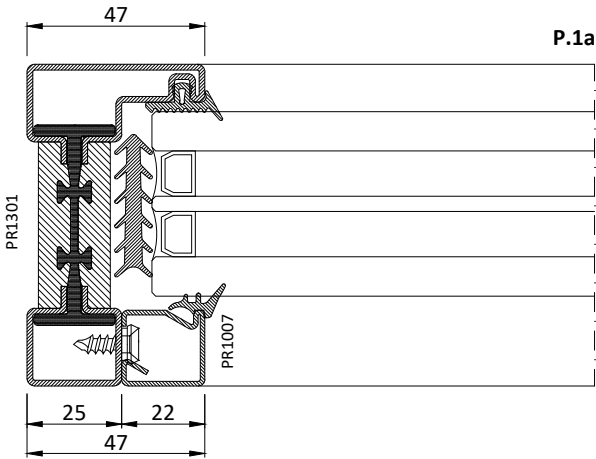
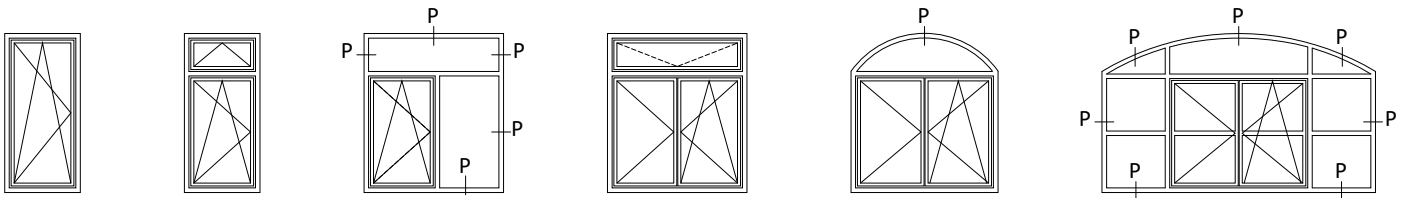

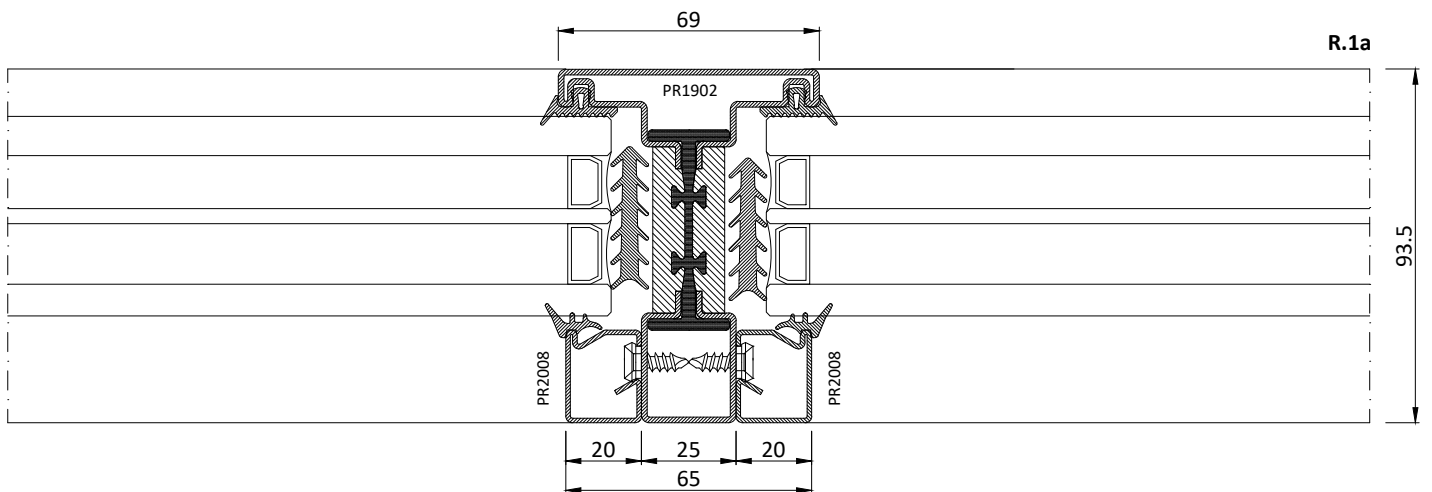
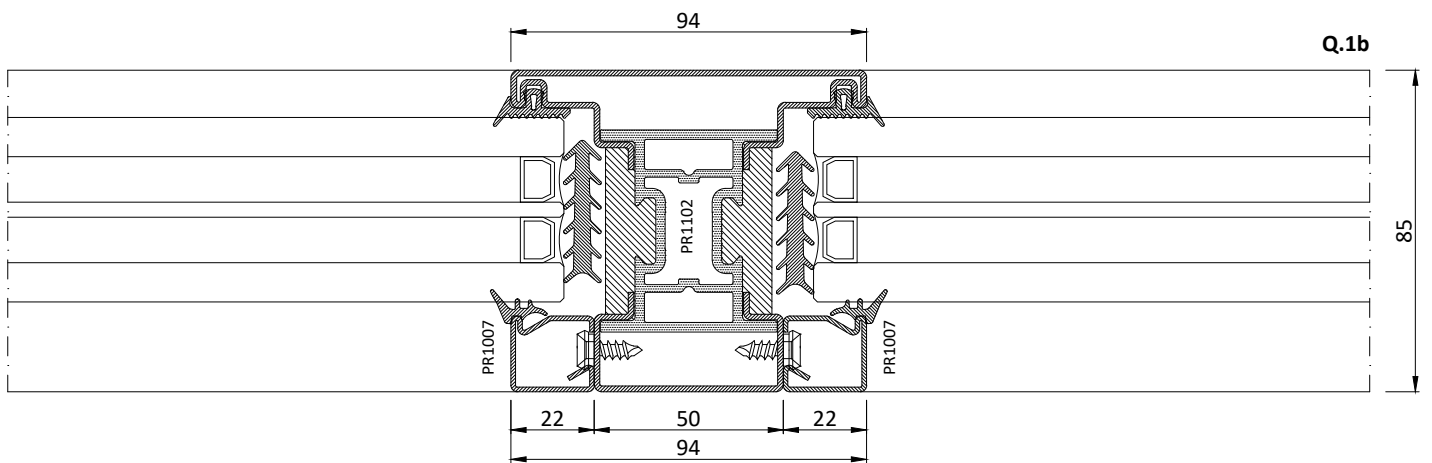
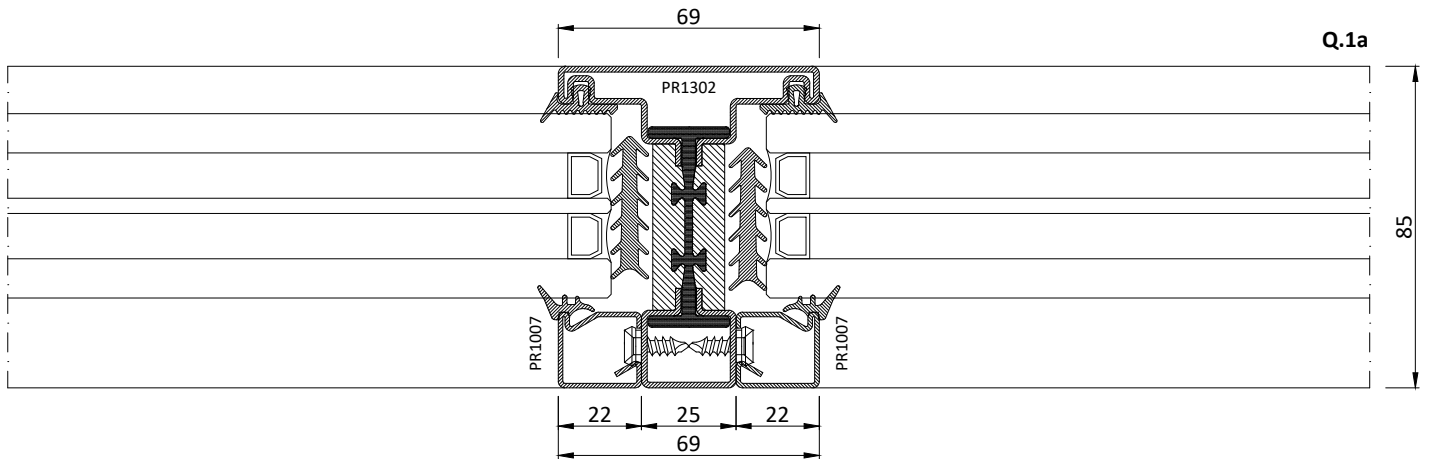
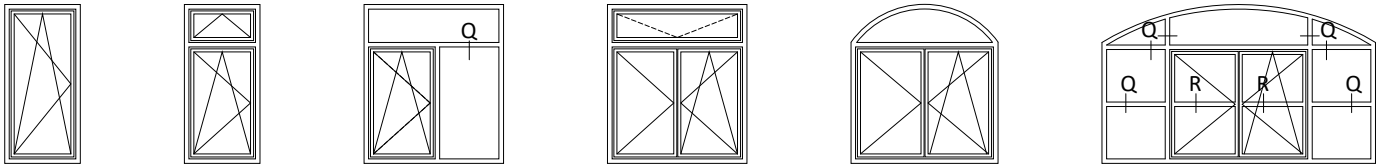

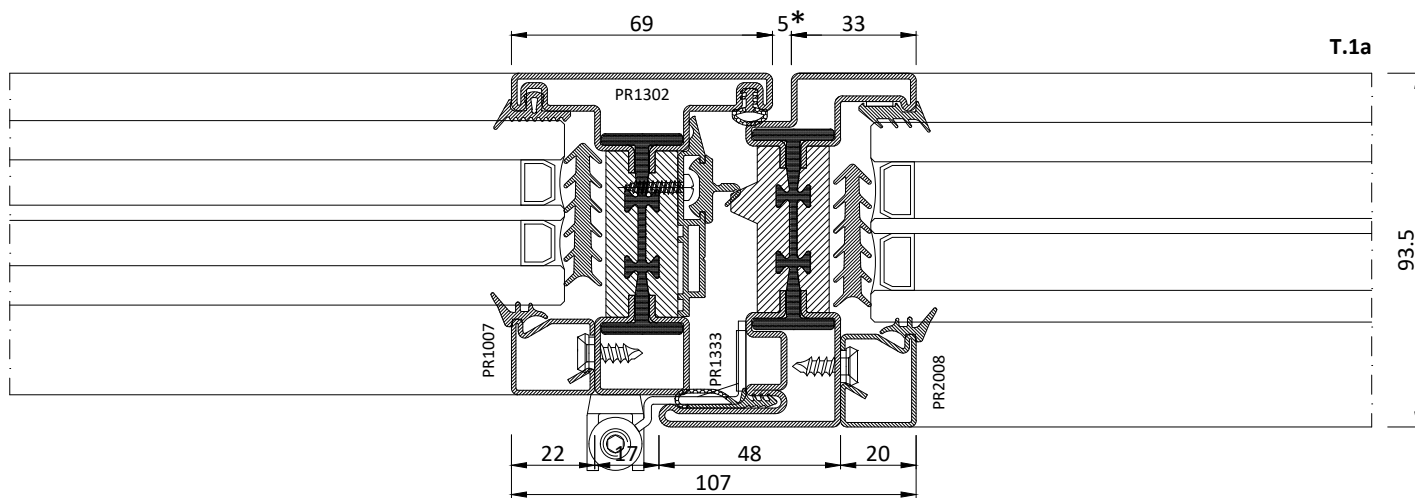
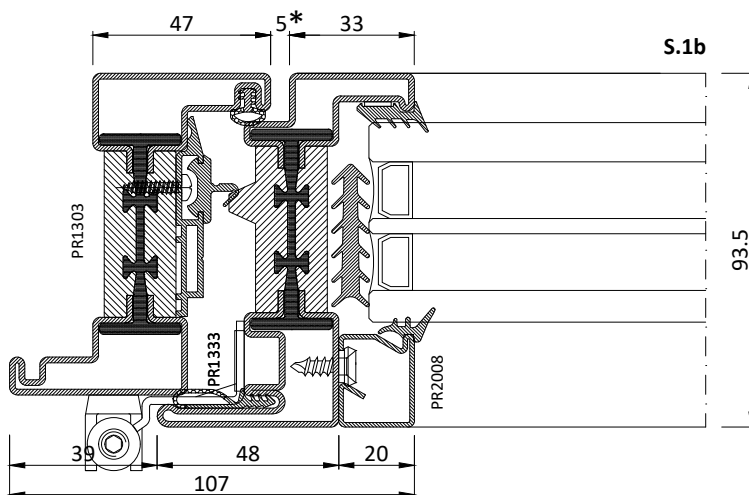
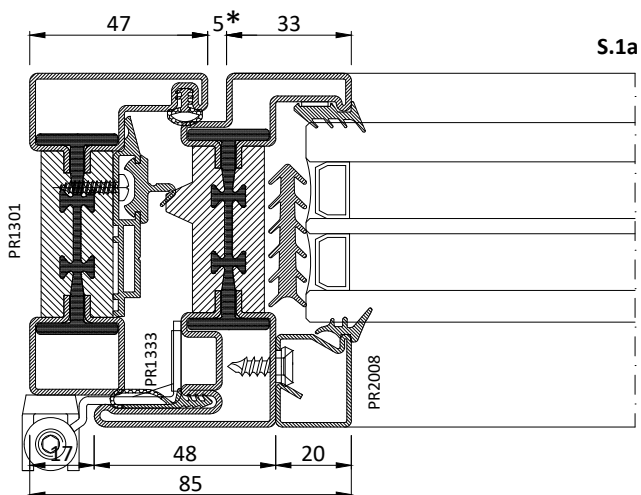
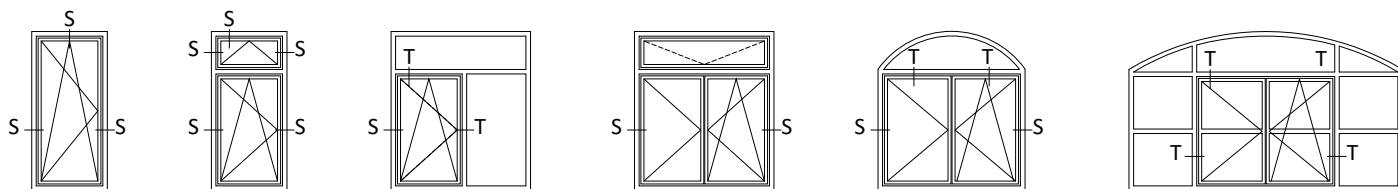

* Vedi tabella 4.1.5
* See chart 4.1.5

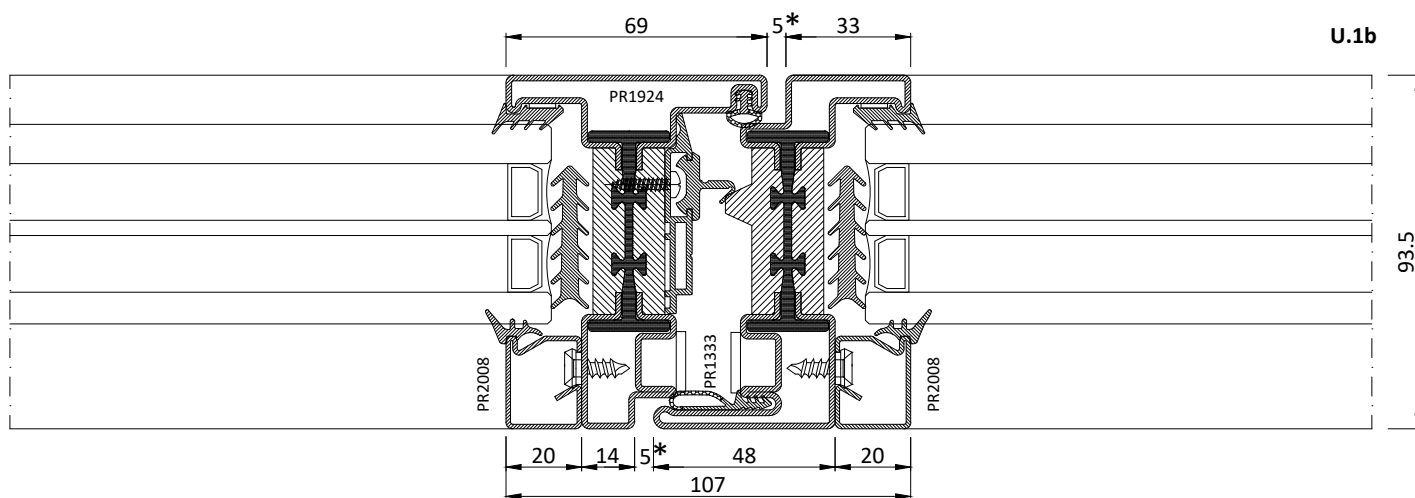
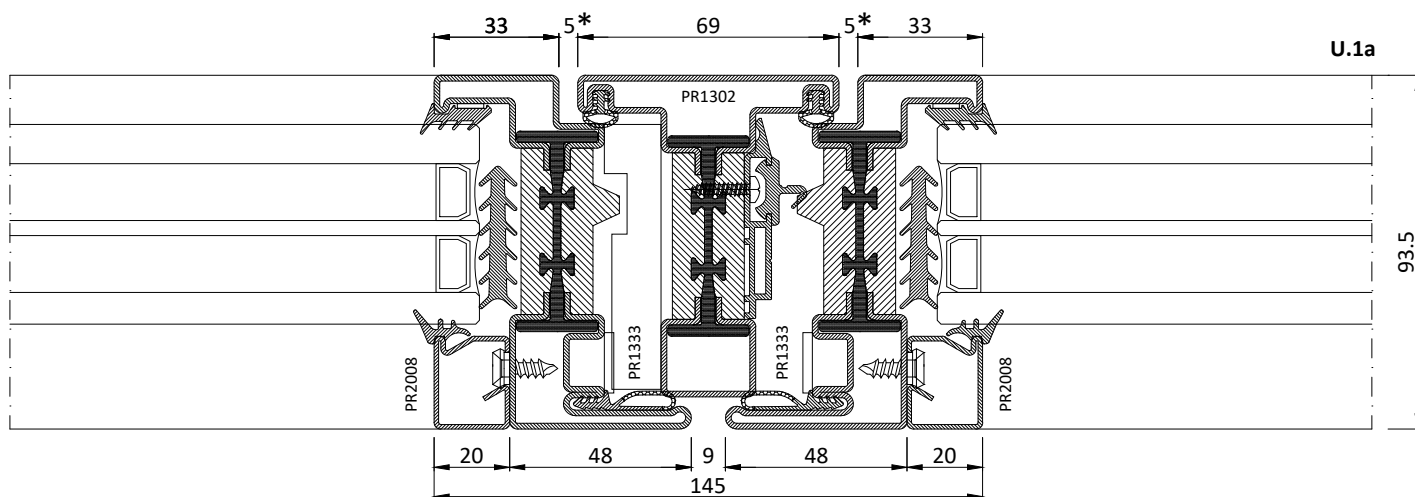
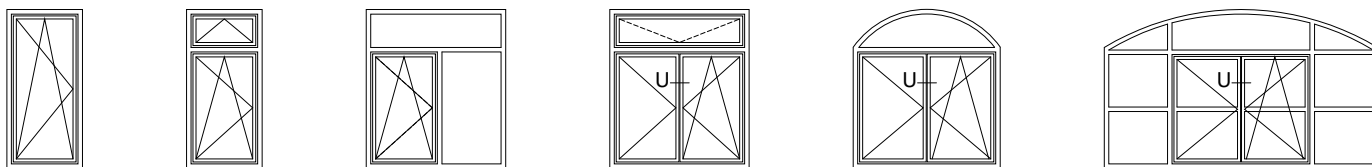

* Vedi tabella 4.1.5
* See chart 4.1.5

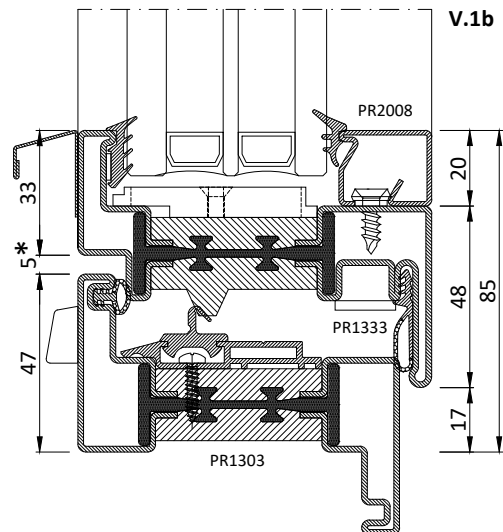
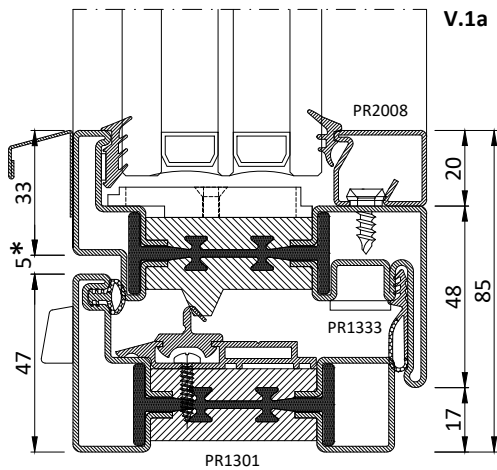
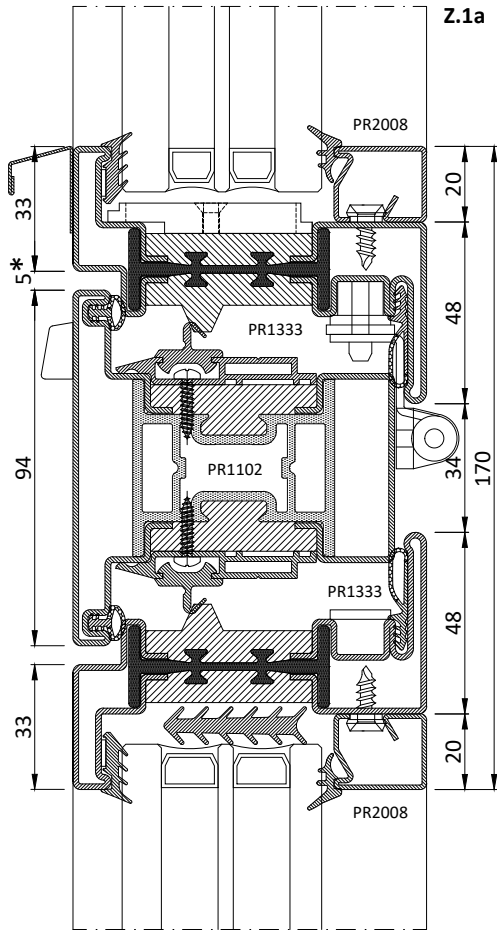
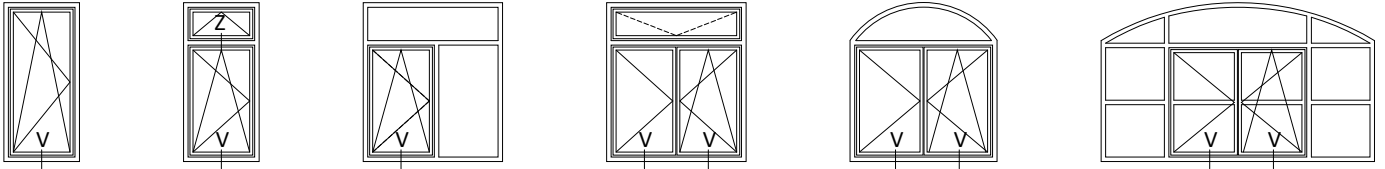

* Vedi tabella 4.1.5
* See chart 4.1.5

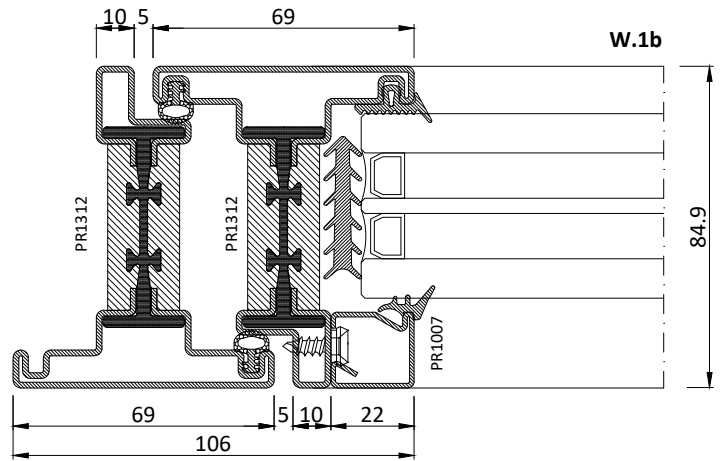
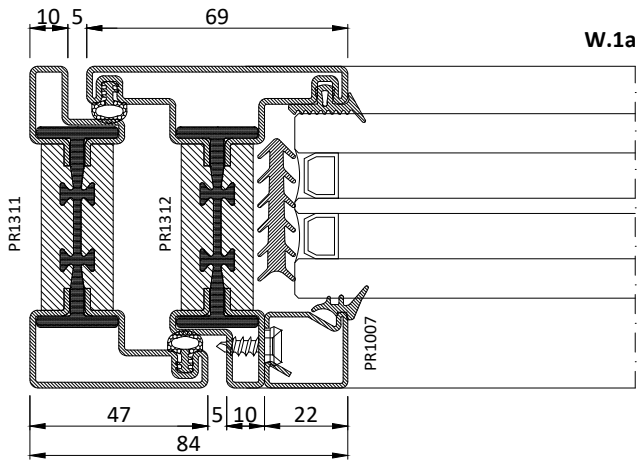
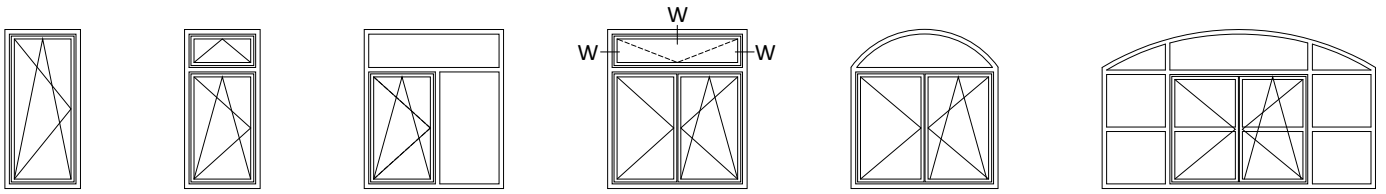

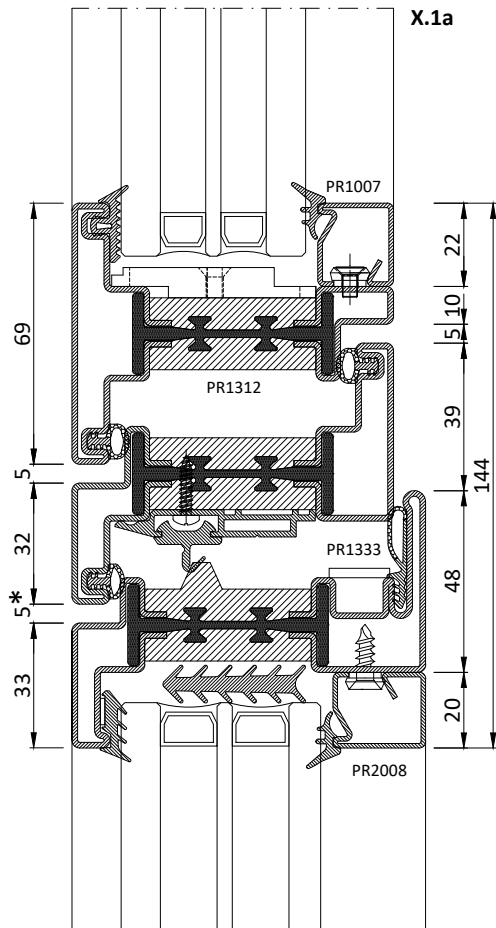
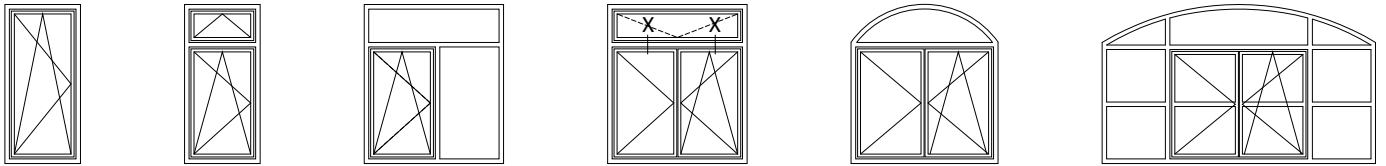

* Vedi tabella 4.1.5
* See chart 4.1.5

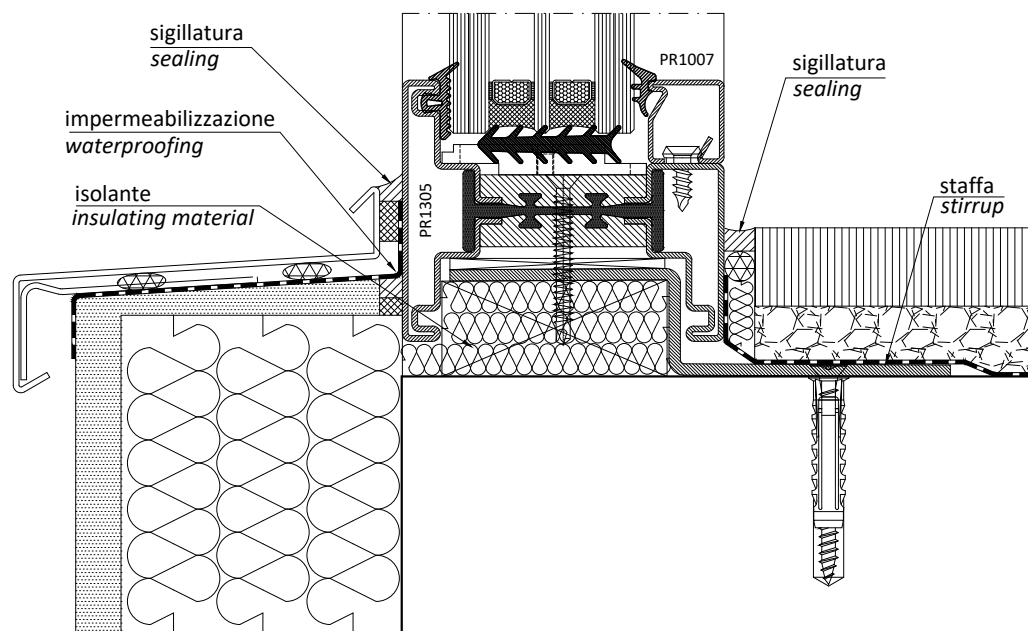
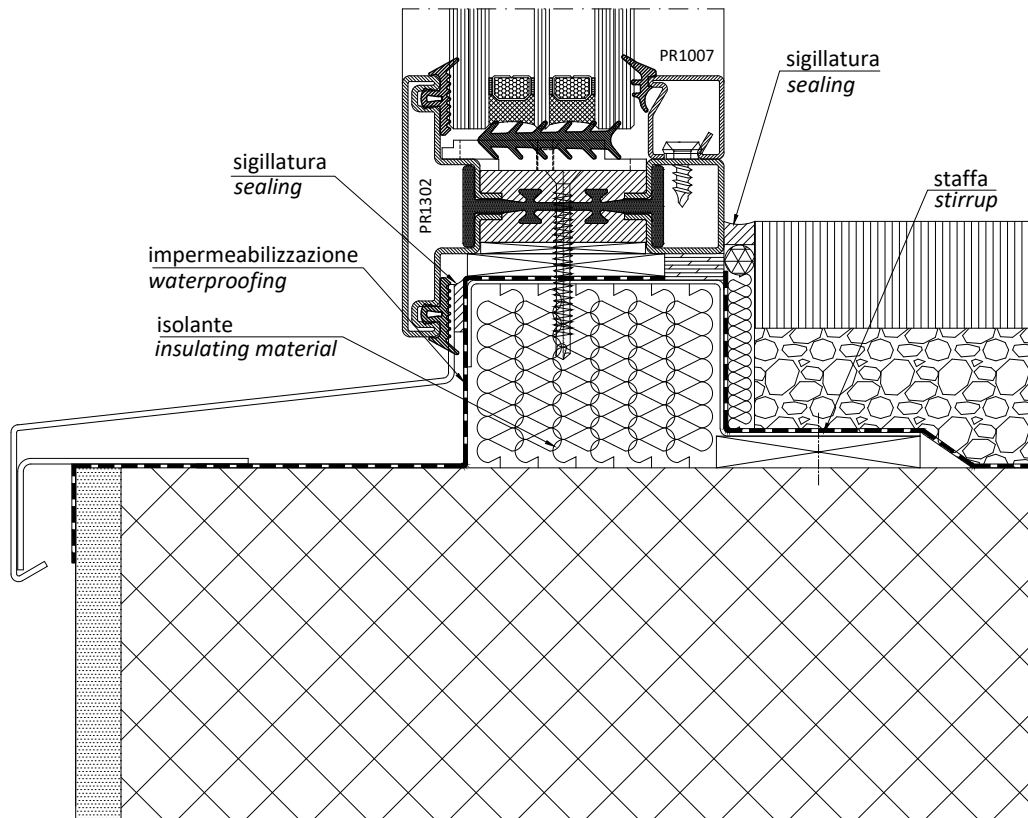

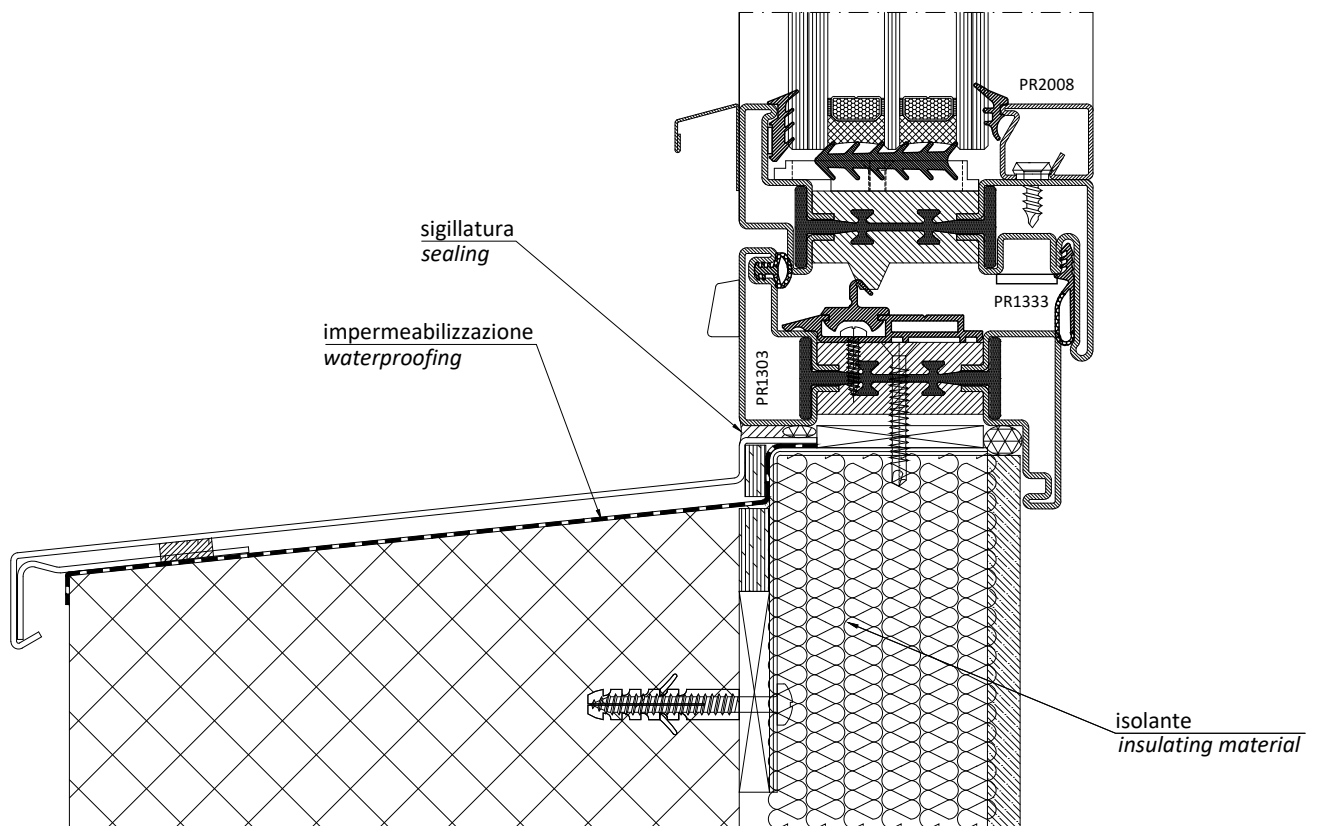
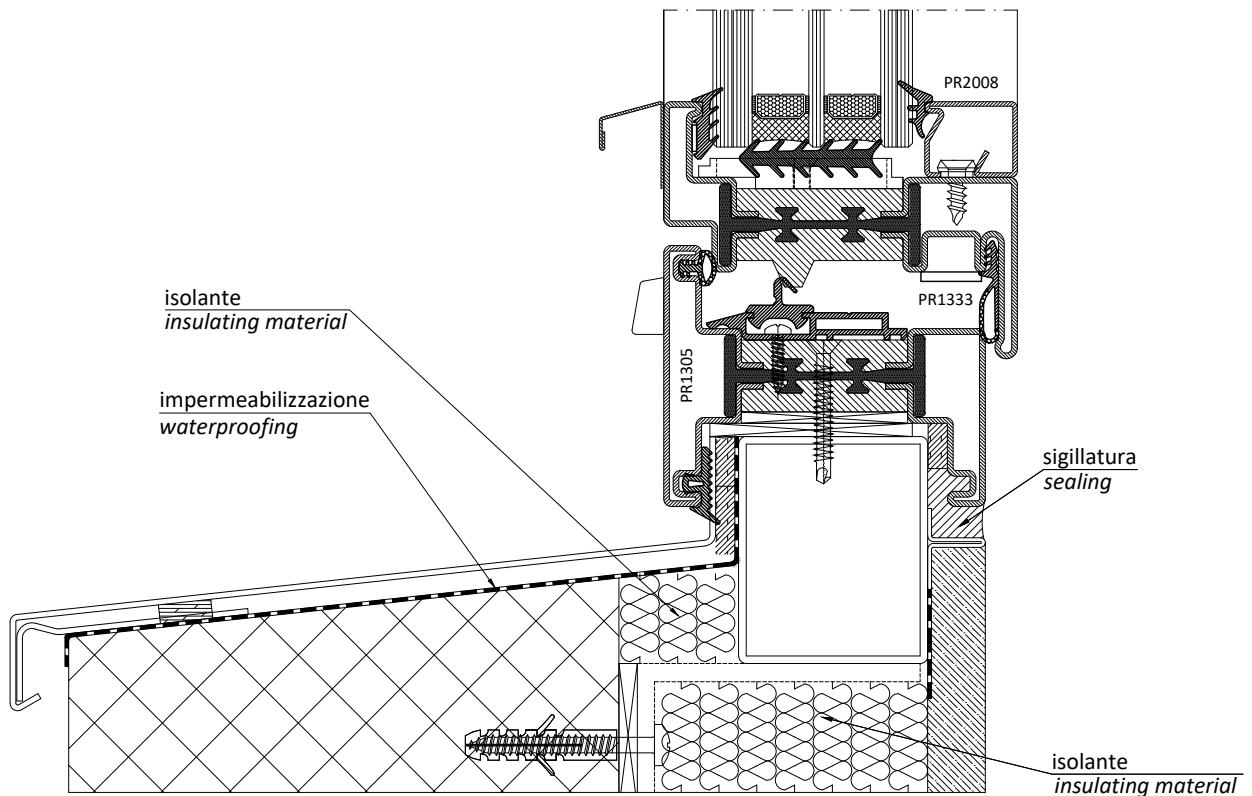

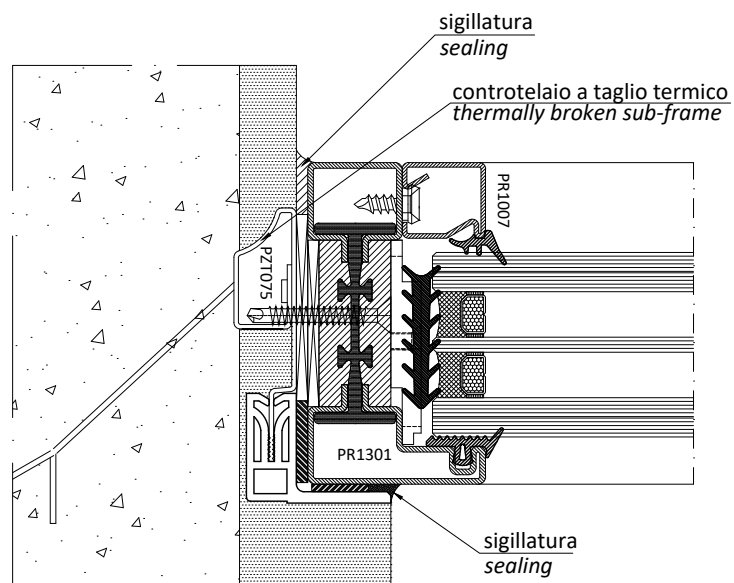
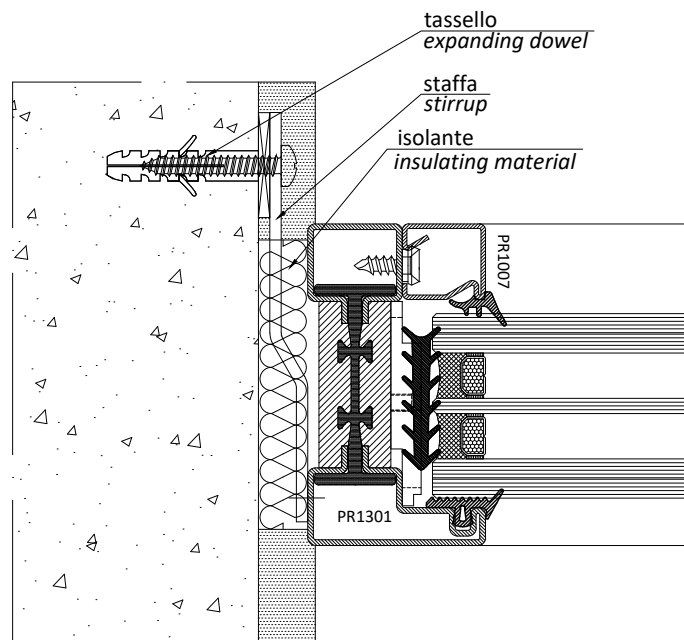
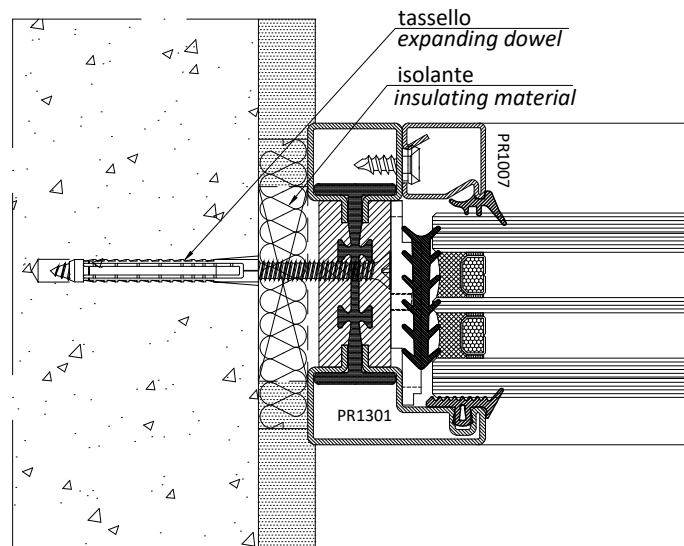

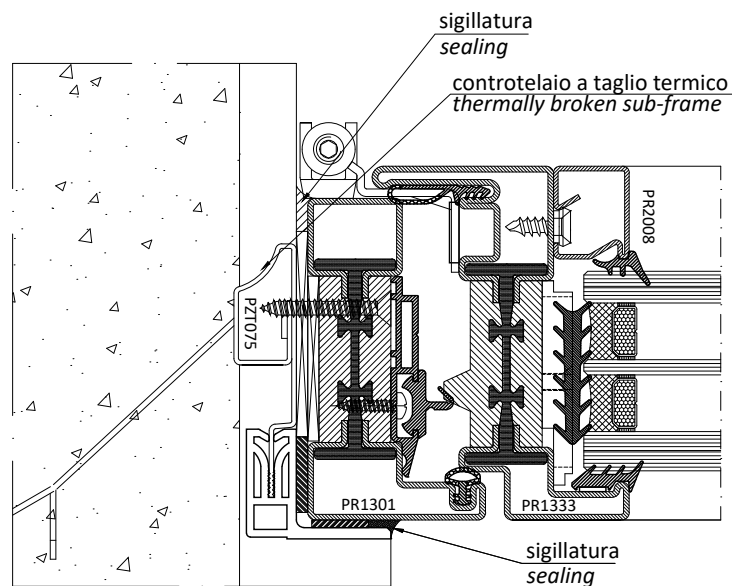
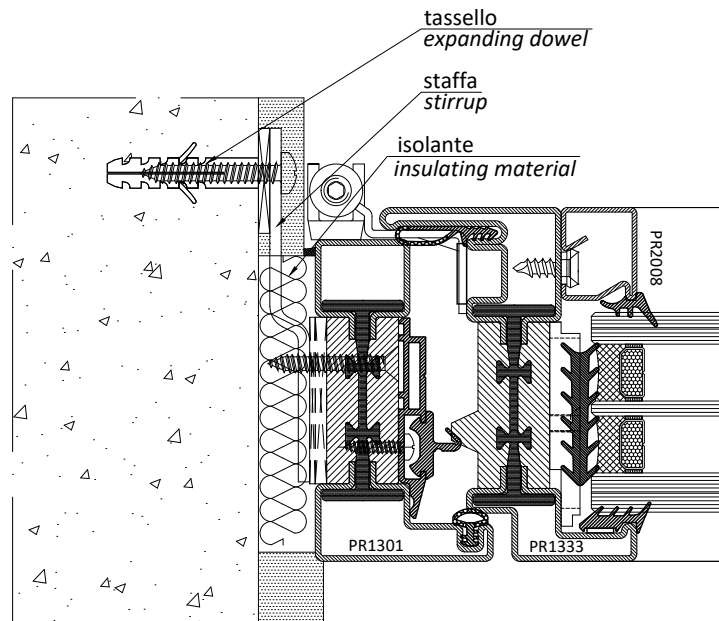
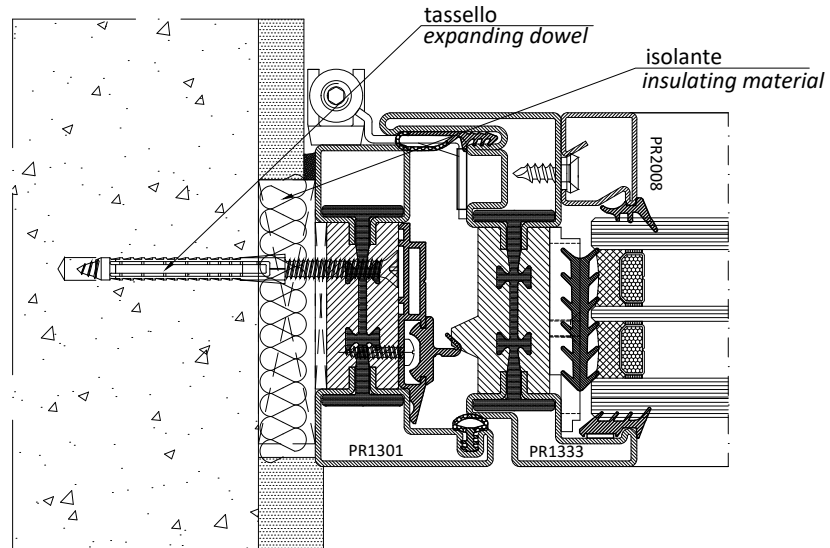

Applicare viti di fissaggio profilo a muro in corrispondenza dell'asse cerniere
Apply anchoring screws to the hinge axis

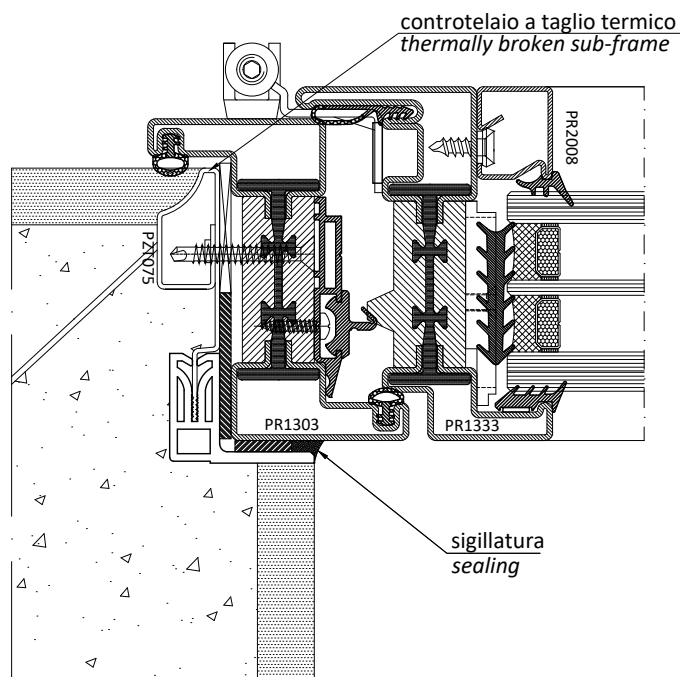
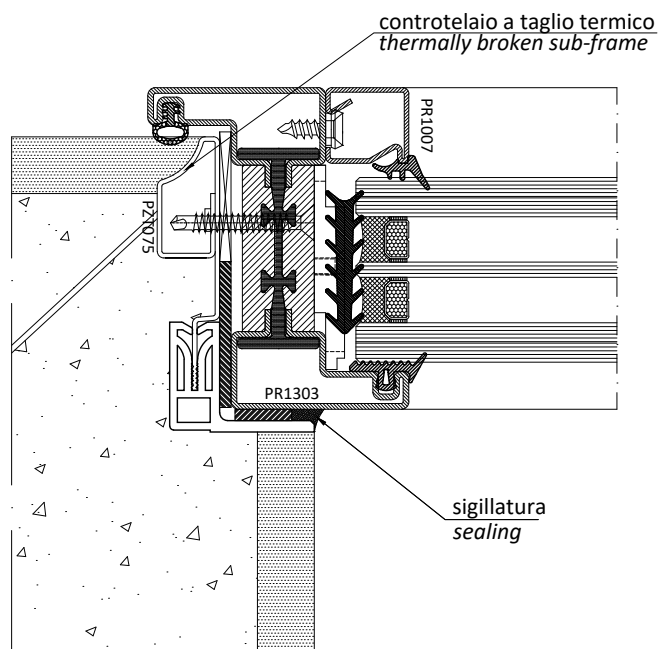

Applicare viti di fissaggio profilo a muro in corrispondenza dell'asse cerniere
Apply anchoring screws to the hinge axis

Distinta di taglio e lista componenti | Cutting list and components list

Le distinte di taglio e le liste accessori individuate per le diverse tipologie sono state redatte per un serramento tipo.

E' compito dei tecnici specializzati delle ditte produttrici analizzare criticamente tali indicazioni al fine di verificare la compatibilità del tipo e numero di accessori previsti con il serramento oggetto della commessa reale.

The cutting and hardware lists, which have been identified for the different typologies, have been produced for a standard window.

The specialized technicians of the window manufacturers will have to critically analyze such information in order to verify the compatibility of both the type and the number of accessories provided with the window object of the real order.

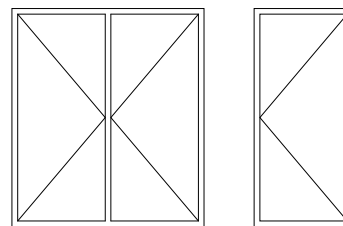

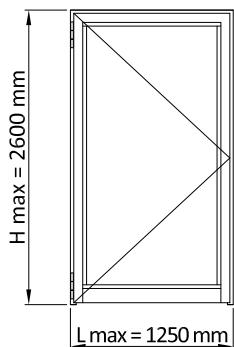

PROFILI		PROFILES			
Cod.	Descrizione	Description	n°	Dim.	Taglio Cutting
Telaio		Frame			
PR1111	Profilo a "L" telaio	"L" profile frame	1	LS	45° 45°
PR1111	Profilo a "L" telaio	"L" profile frame	1	HS	45° 90°
PR1111	Profilo a "L" telaio	"L" profile frame	1	HS	90° 45°
Anta		Leaf			
PR1113	Profilo a "Z" anta	"Z" profile leaf	1	LS-80	45° 45°
PR1113	Profilo a "Z" anta	"Z" profile leaf	1	HS-45	45° 90°
PR1113	Profilo a "Z" anta	"Z" profile leaf	1	HS-45	90° 45°
PR1105	Profilo zoccolo	Socle profile	1	LS-224	90° 90°
Fermavetri		Glazing beads			
PR1007	Fermavetro	Glazing bead profile	2	LS-224	90° 90°
PR1007	Fermavetro	Glazing bead profile	2	HS-233	90° 90°
Vetri		Glass unit			
-	Vetrocamera	Insulated glass	1	LS-240 x HS-205	

ACCESSORI		HARDWARE	
Cod.	Descrizione	Description	n°
AC1004*	Kit squadrette per PR1111	Corner joint kit for PR1111	2
AC1007*	Kit squadrette per PR1113	Corner joint kit for PR1113	2
AC1021*	Cavallotto per PR1105	Butt joint kit PR1105	2
AC1020 ..	Supporto spessore vetro	Glass support	6
AC1033 ..	Cerniera a stilo	Road hinges	Var.
AC1065/6/7..	Serratura multipunto	Multi-point lock	1
AC1081/..	Paraspiffero automatico	Authomatic door seal	1
ACV9...	Maniglia "Vitruvio"	"Vitruvio" handle	1
ACV085	Quadro maniglia	Spindle bar handle	1
CV5001(I)	Vite per boccola fermavetro	Screw for glazing bead bushing	Var.
CV5012(I)	Boccola per fermavetro	Bushing for glazing bead	Var.

GUARNIZIONI		GASKETS	
Cod.	Descrizione	Description	n° Dim.
GE1001TT	Guarnizione esterna di battuta	Rebating gasket	1 2xLS+4xHS
GE1006	Guarnizione esterna vetro	External gasket	1 2xLS+2xHS
GE1007TT	Guarnizione sottovetro	Gasket to put under the glass	1 2xLS+2xHS
GE..	Guarnizione interna vetro	Internal gasket	1 2xLS+2xHS

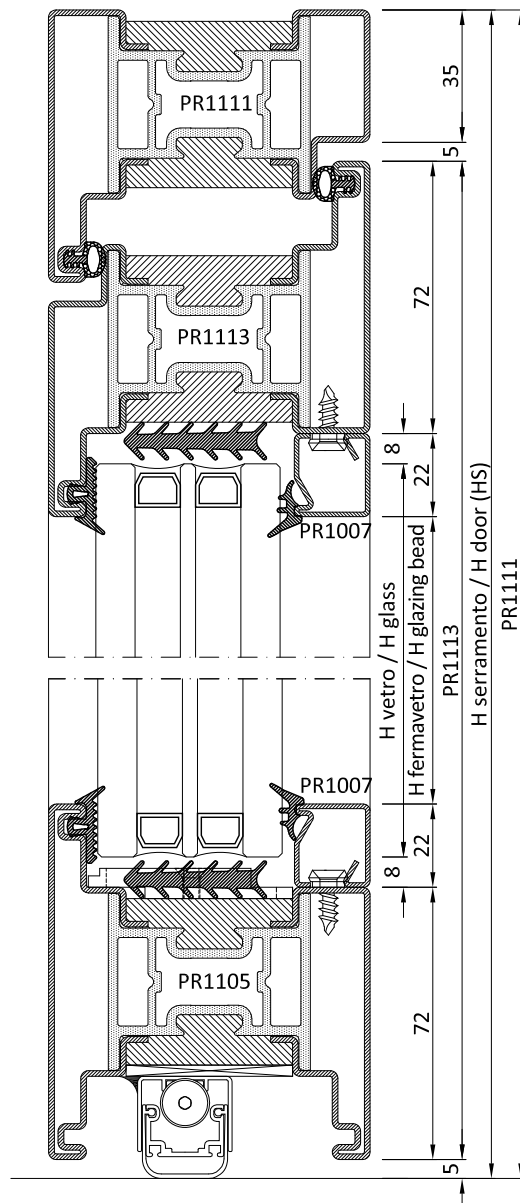

* solo con profili ottone
only with brass profiles

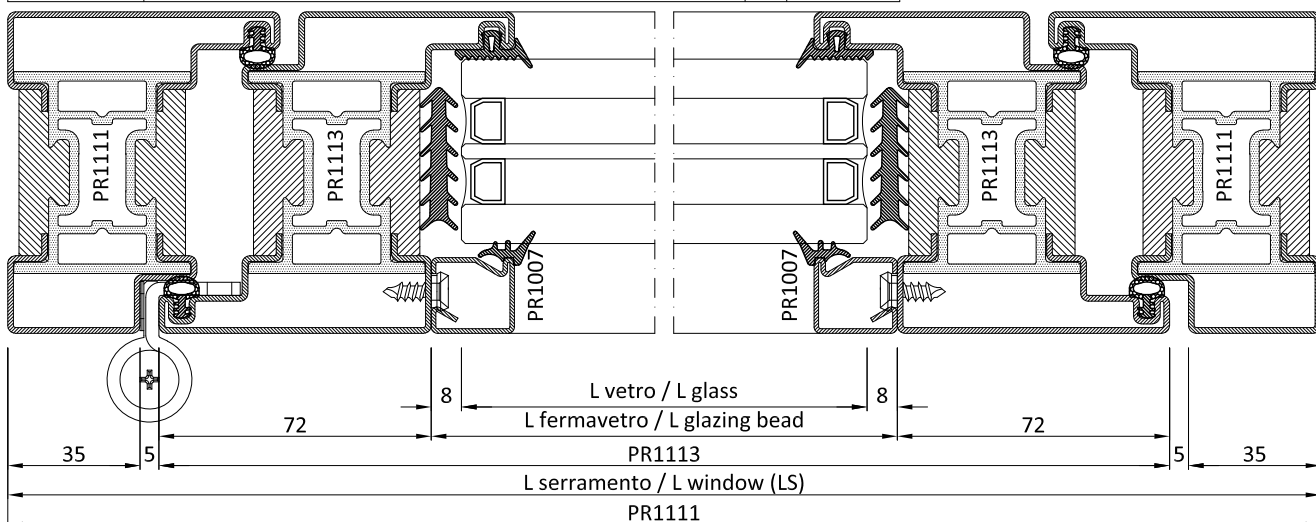

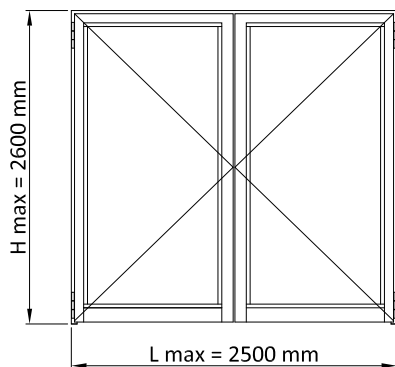

PROFILI		PROFILES				
Cod.	Descrizione	Description	n°	Dim.	Taglio	Cutting
Telaio		Frame				
PR1111	Profilo a "L" telaio	"L" profile frame	1	LS	45°	45°
PR1111	Profilo a "L" telaio	"L" profile frame	1	HS	45°	90°
PR1111	Profilo a "L" telaio	"L" profile frame	1	HS	90°	45°
Anta		Leaf				
PR1113	Profilo a "Z" anta	"Z" profile leaf	2	(LS-48)/2	45°	45°
PR1113	Profilo a "Z" anta	"Z" profile leaf	2	HS-45	45°	90°
PR1113	Profilo a "Z" anta	"Z" profile leaf	1	HS-45	90°	45°
PR1112	Profilo a "T" anta	"T" profile leaf	1	HS-45	90°	45°
PR1105	Profilo zoccolo	Socle profile	2	(LS-336)/2	90°	90°
Fermavetri		Glazing beads				
PR1007	Fermavetro	Glazing bead profile	4	(LS-336)/2	90°	90°
PR1007	Fermavetro	Glazing bead profile	4	HS-233	90°	90°
Vetri		Glass unit				
-	Vetrocamera	Insulated glass	2	(LS-368)/2 x HS-205		

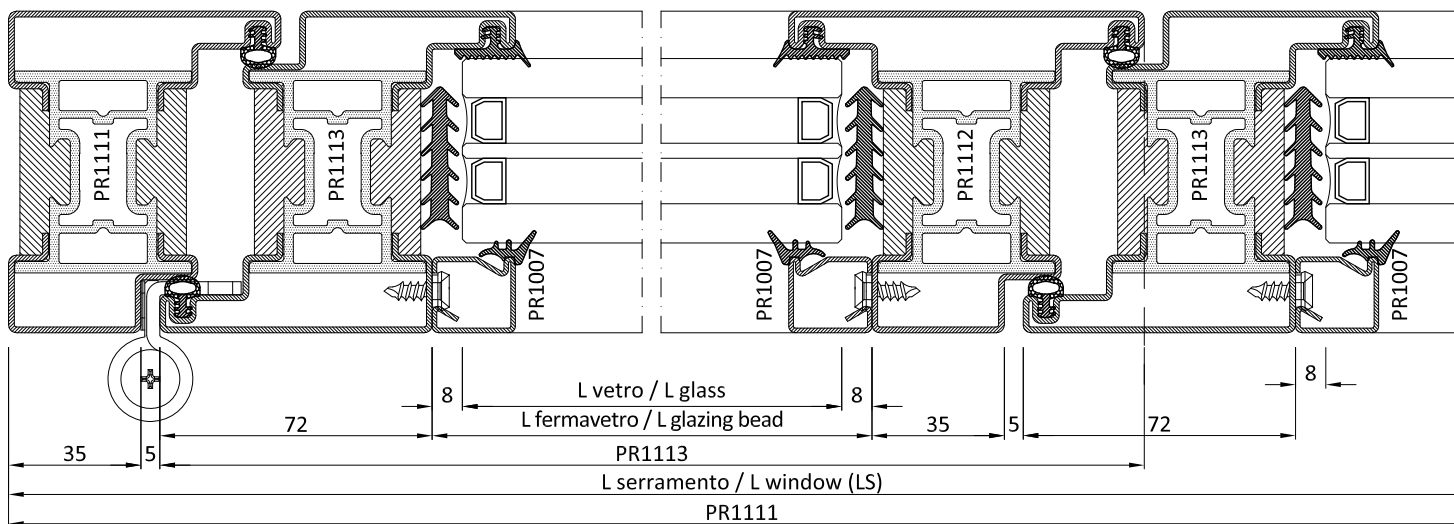

ACCESSORI		HARDWARE	
Cod.	Descrizione	Description	n°
AC1004*	Kit squadrette per PR1111	Corner joint kit for PR1111	2
AC1007*	Kit squadrette per PR1113	Corner joint kit for PR1113	3
AC1008*	Kit squadrette per PR1113-12	Corner joint kit for PR1113-12	1
AC1021*	Cavallotto per PR1105	Butt joint kit PR1105	4
AC1014	Fondino inversione battuta	Steel ending cap for reverting rebate	2
AC1020 ..	Supporto spessore vetro	Glass support	12
AC1033 ..	Cerniera a stilo	Road hinges	Var.
AC1040	Kit catenaccio 2^ anta	Kit for closing second leaf	1
AC1065/6/7..	Serratura multipunto	Multi-point lock	1
AC1081/..	Paraspiffero automatico	Authomatic door seal	2
ACV9...	Maniglia "Vitruvio"	"Vitruvio" handle	1
ACV085	Quadro maniglia	Spindle bar handle	1
CV5001(I)	Vite per boccia fermavetro	Screw for glazing bead bushing	Var.
CV5012(I)	Boccia per fermavetro	Bushing for glazing bead	Var.

GUARNIZIONI		GASKETS	
Cod.	Descrizione	Description	n° Dim.
GE1001TT	Guarnizione esterna di battuta	Rebating gasket	1 2xLS+6xHS
GE1006	Guarnizione esterna vetro	External gasket	1 2xLS+4xHS
GE1007TT	Guarnizione sottovetro	Gasket to put under the glass	1 2xLS+4xHS
GE..	Guarnizione interna vetro	Internal gasket	1 2xLS+4xHS

* solo con profili ottone
only with brass profiles

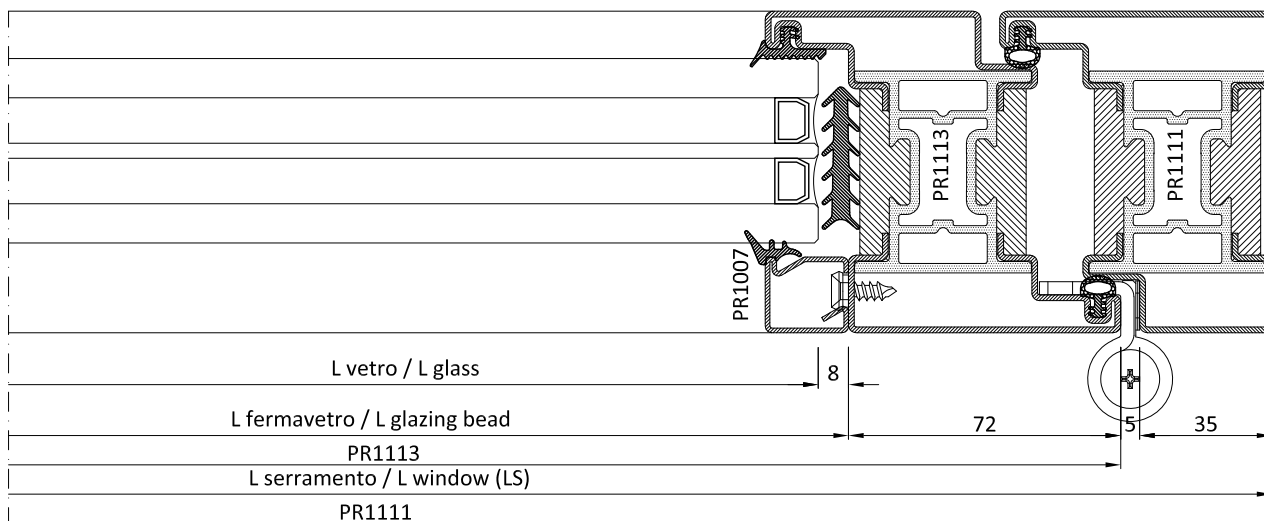
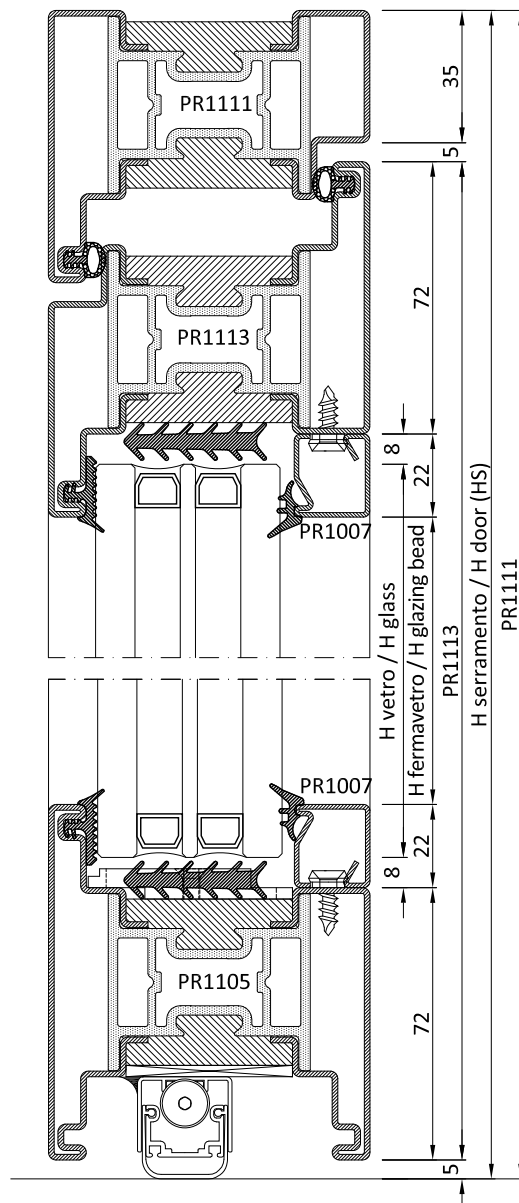

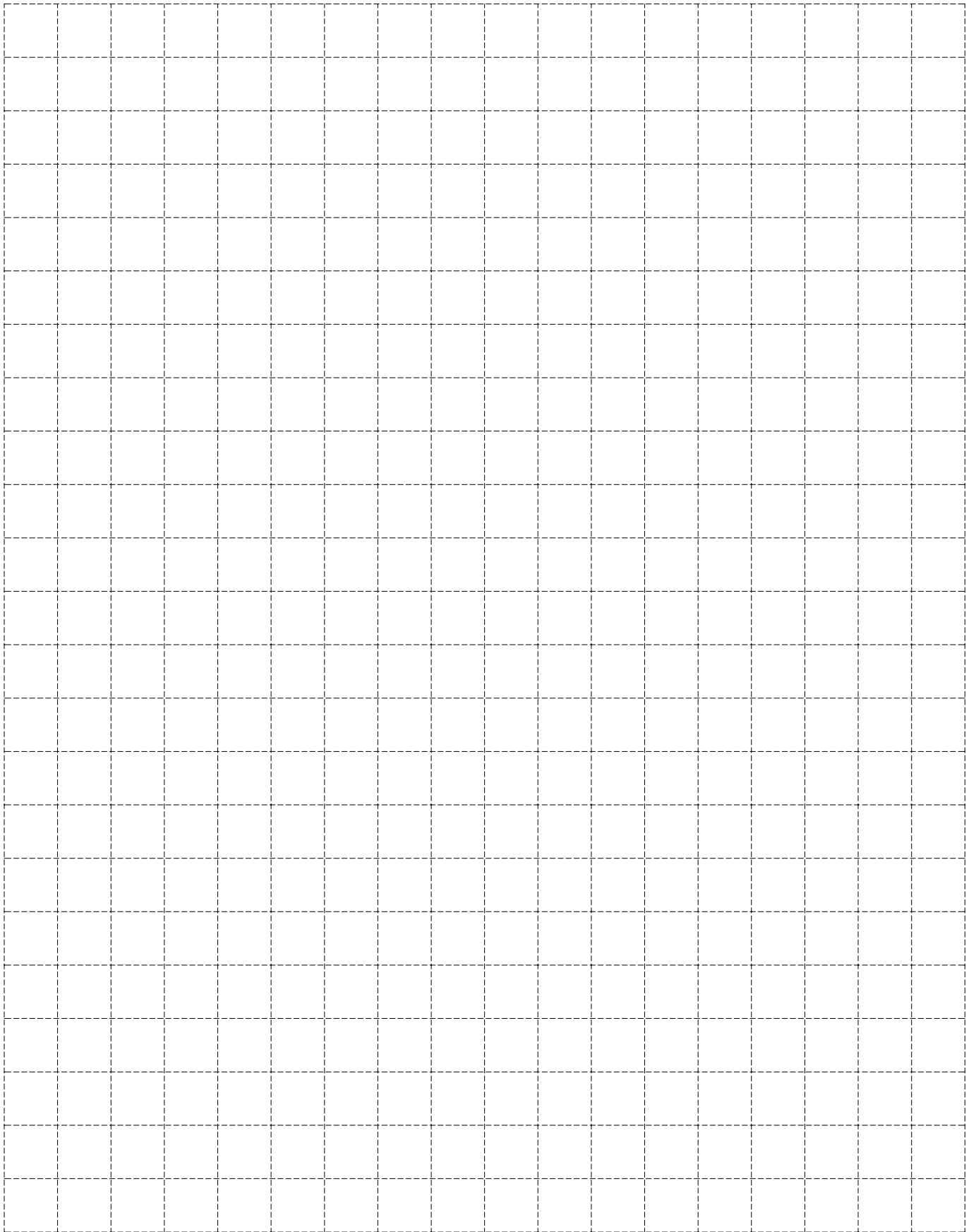

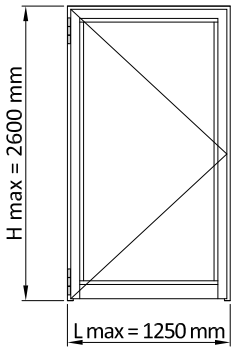

PROFILI		PROFILES			
Cod.	Descrizione	Description	n°	Dim.	Taglio Cutting
Telaio			Frame		
PR1111	Profilo a "L" telaio	"L" profile frame	1	LS	45° 45°
PR1111	Profilo a "L" telaio	"L" profile frame	1	HS	45° 90°
PR1111	Profilo a "L" telaio	"L" profile frame	1	HS	90° 45°
Anta			Leaf		
PR1112	Profilo a "Z" anta	"Z" profile leaf	1	LS-80	45° 45°
PR1112	Profilo a "Z" anta	"Z" profile leaf	1	HS-45	45° 90°
PR1112	Profilo a "Z" anta	"Z" profile leaf	1	HS-45	90° 45°
PR1105	Profilo zoccolo	Socle profile	1	LS-224	90° 90°
Fermavetri			Glazing beads		
PR1007	Fermavetro	Glazing bead profile	2	LS-224	90° 90°
PR1007	Fermavetro	Glazing bead profile	2	HS-233	90° 90°
Vetri			Glass unit		
-	Vetrocamera	Insulated glass	1	LS-240 x HS-205	
ACCESSORI			HARDWARE		
Cod.	Descrizione	Description	n°		
AC1004*	Kit squadrette per PR1111	Corner joint kit for PR1111	2		
AC1005*	Kit squadrette per PR1112	Corner joint kit for PR1112	2		
AC1021*	Cavallotto per PR1105	Butt joint kit PR1105	2		
AC1020 ..	Supporto spessore vetro	Glass support	6		
AC1033 ..	Cerniera a stilo	Road hinges	Var.		
AC1065/6/7..	Serratura multipunto	Multi-point lock	1		
AC1081/..	Paraspiffero automatico	Authomatic door seal	1		
ACV9...	Maniglia "Vitruvio"	"Vitruvio" handle	1		
ACV085	Quadro maniglia	Spindle bar handle	1		
CV5001(I)	Vite per boccola fermavetro	Screw for glazing bead bushing	Var.		
CV5012(I)	Boccola per fermavetro	Bushing for glazing bead	Var.		
GUARNIZIONI			GASKETS		
Cod.	Descrizione	Description	n°	Dim.	
GE1001TT	Guarnizione esterna di battuta	Rebating gasket	1	2xLS+4xHS	
GE1006	Guarnizione esterna vetro	External gasket	1	2xLS+2xHS	
GE1007TT	Guarnizione sottovetro	Gasket to put under the glass	1	2xLS+2xHS	
GE..	Guarnizione interna vetro	Internal gasket	1	2xLS+2xHS	

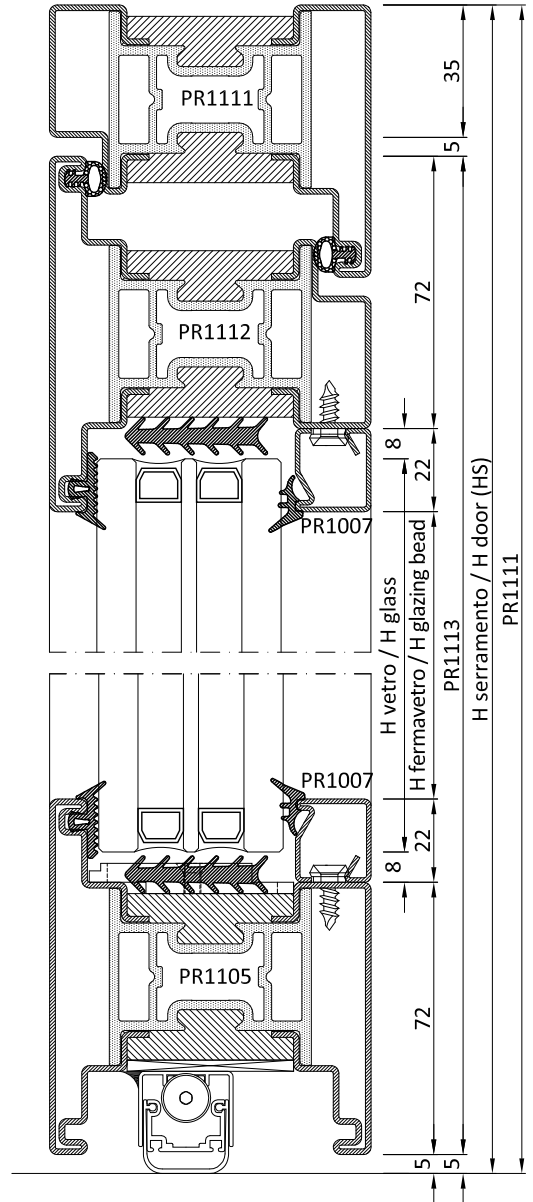

* solo con profili ottone
only with brass profiles

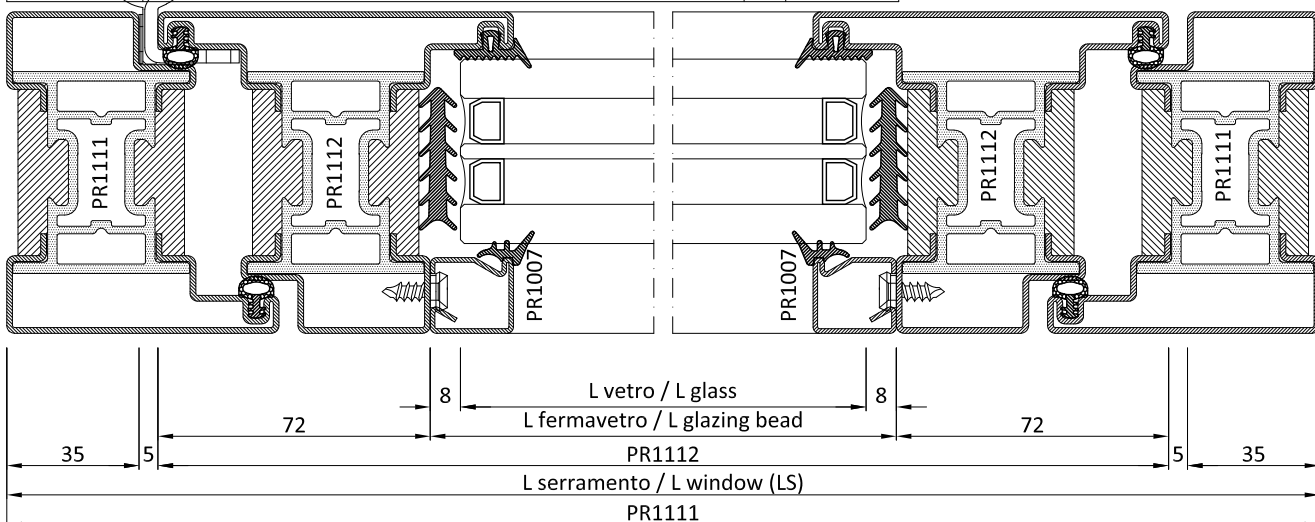

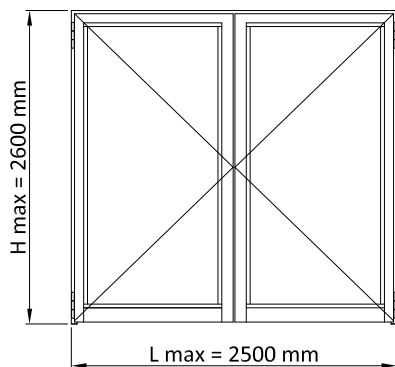

PROFILI		PROFILES				
Cod.	Descrizione	Description	n°	Dim.	Taglio	Cutting
Telaio		Frame				
PR1111	Profilo a "L" telaio	"L" profile frame	1	LS	45°	45°
PR1111	Profilo a "L" telaio	"L" profile frame	1	HS	45°	90°
PR1111	Profilo a "L" telaio	"L" profile frame	1	HS	90°	45°
Anta		Leaf				
PR1112	Profilo a "Z" anta	"Z" profile leaf	1	(LS-48)/2	45°	45°
PR1112	Profilo a "Z" anta	"Z" profile leaf	1	HS-45	45°	90°
PR1112	Profilo a "Z" anta	"Z" profile leaf	1	HS-45	90°	45°
PR1113	Profilo a "T" anta	"T" profile leaf	1	HS-45	90°	45°
PR1105	Profilo zoccolo	Socle profile	1	(LS-336)/2	90°	90°
Fermavetri		Glazing beads				
PR1007	Fermavetro	Glazing bead profile	2	(LS-336)/2	90°	90°
PR1007	Fermavetro	Glazing bead profile	2	HS-233	90°	90°
Vetri		Glass unit				
-	Vetrocamera	Insulated glass	1	(LS-368)/2 x HS-205		

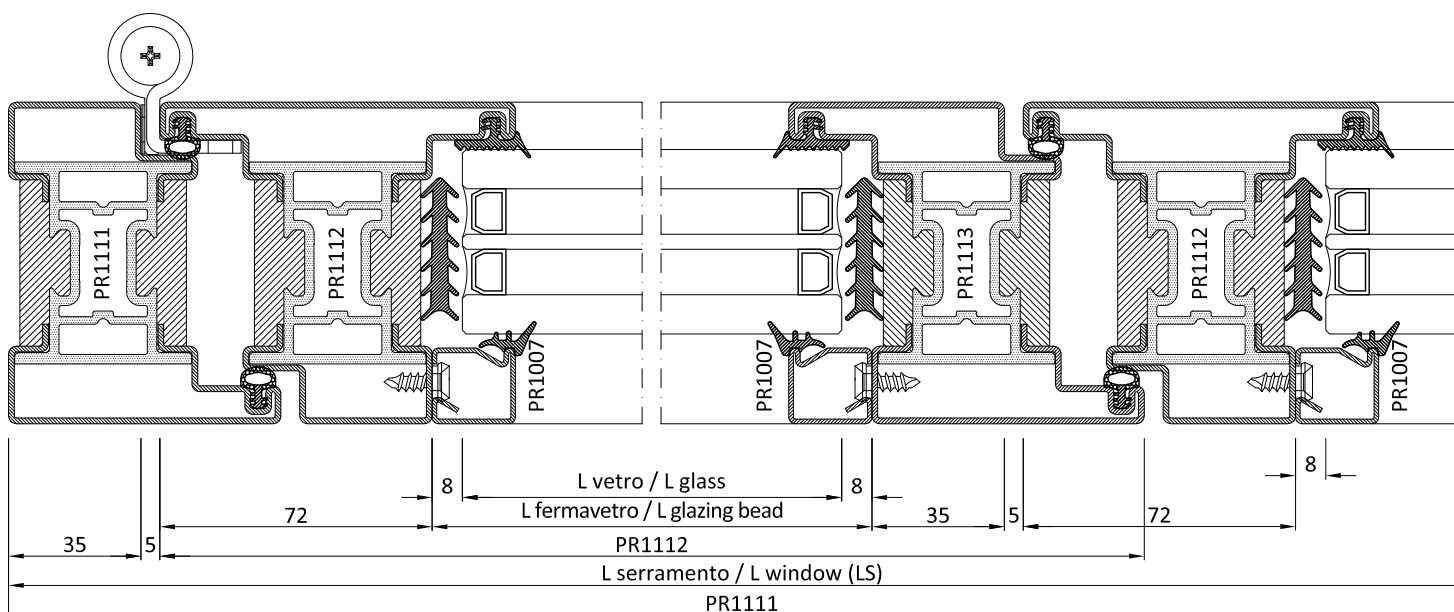

ACCESSORI		HARDWARE	
Cod.	Descrizione	Description	n°
AC1004*	Kit squadrette per PR1111	Corner joint kit for PR1111	2
AC1005*	Kit squadrette per PR1112	Corner joint kit for PR1112	3
AC1008*	Kit squadrette per PR1113-12	Corner joint kit for PR1113-12	1
AC1021*	Cavallotto per PR1105	Butt joint kit PR1105	4
AC1014	Fondino inversione battuta	Steel ending cap for reverting rebate	2
AC1020 ..	Supporto spessore vetro	Glass support	12
AC1033 ..	Cerniera a stilo	Road hinges	Var.
AC1040	Kit catenaccio 2^ anta	Kit for closing second leaf	1
AC1065/6/7..	Serratura multipunto	Multi-point lock	1
AC1081/..	Paraspiffero automatico	Authomatic door seal	2
ACV9...	Maniglia "Vitruvio"	"Vitruvio" handle	1
ACV085	Quadro maniglia	Spindle bar handle	1
CV5001(i)	Vite per boccia fermavetro	Screw for glazing bead bushing	Var.
CV5012(i)	Boccia per fermavetro	Bushing for glazing bead	Var.

GUARNIZIONI		GASKETS	
Cod.	Descrizione	Description	n° Dim.
GE1001TT	Guarnizione esterna di battuta	Rebating gasket	1 2xLS+6xHS
GE1006	Guarnizione esterna vetro	External gasket	1 2xLS+4xHS
GE1007TT	Guarnizione sottovetro	Gasket to put under the glass	1 2xLS+4xHS
GE..	Guarnizione interna vetro	Internal gasket	1 2xLS+4xHS

* solo con profili ottone
only with brass profiles

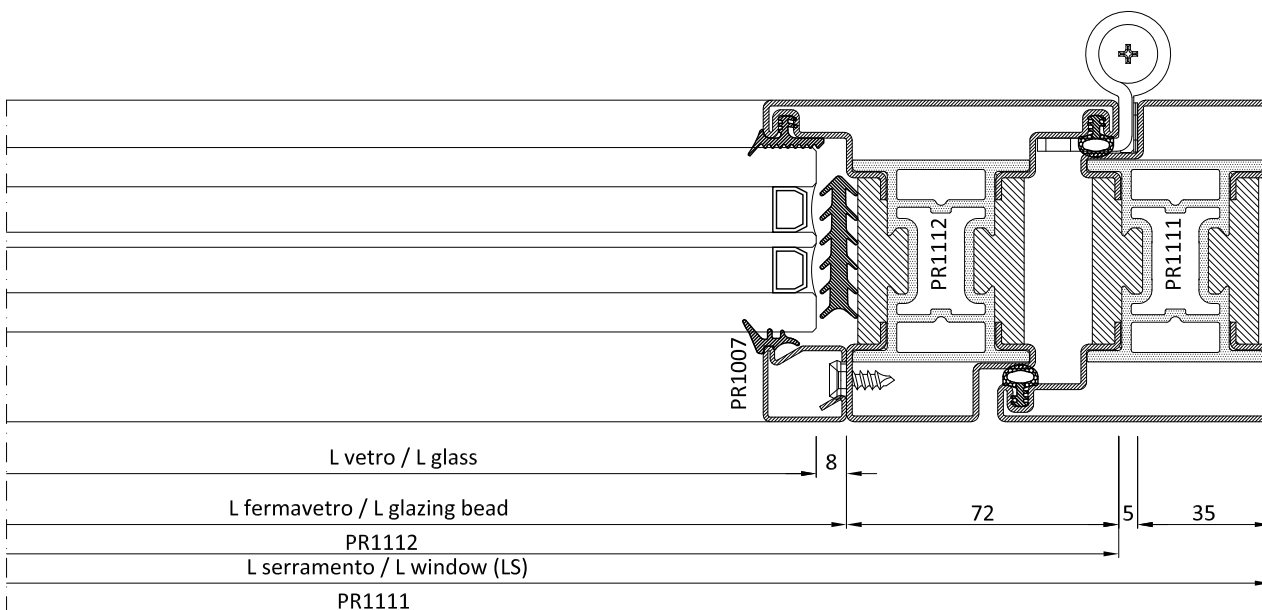
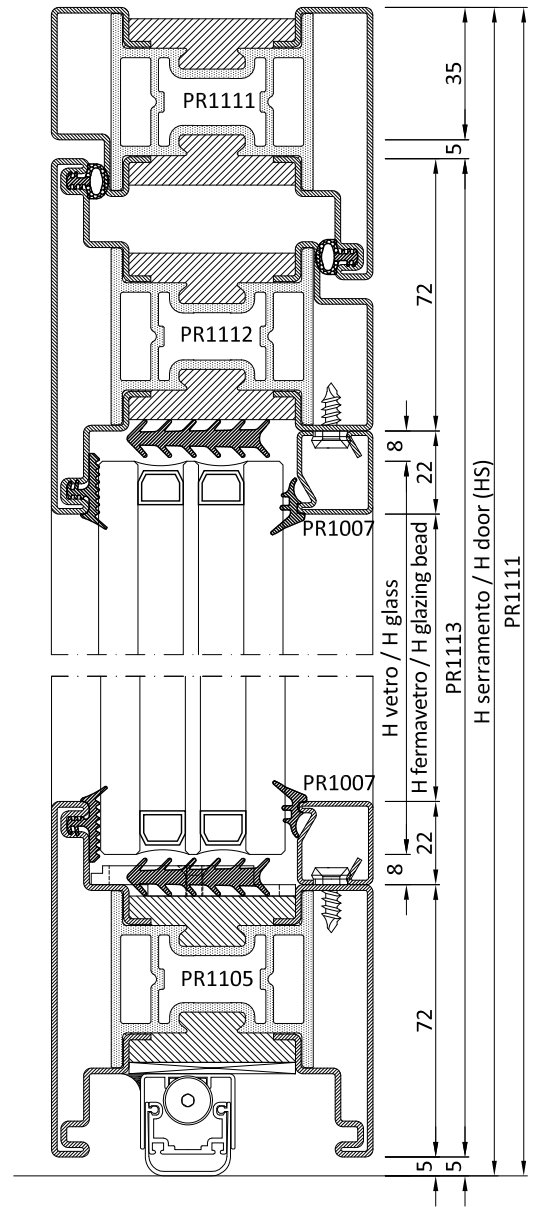

Distinta di taglio e lista componenti | Cutting list and components list

Le distinte di taglio e le liste accessori individuate per le diverse tipologie sono state redatte per un serramento tipo.
E' compito dei tecnici specializzati delle ditte produttrici analizzare criticamente tali indicazioni al fine di verificare la compatibilità del tipo e numero di accessori previsti con il serramento oggetto della commessa reale.

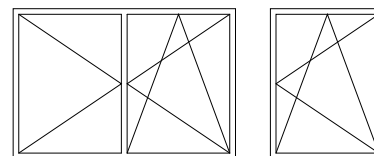

The cutting and hardware lists, which have been identified for the different typologies, have been produced for a standard window.

The specialized technicians of the window manufacturers will have to critically analyze such information in order to verify the compatibility of both the type and the number of accessories provided with the window object of the real order.

La tabella seguente va attentamente letta prima del taglio dei profili | The following table should be carefully read before the profiles cutting

In essa è riportata la misura da considerare nella distanza tra telaio anta e telaio fisso nella produzione di finestre in funzione della tipologia, del tipo di cerniera e della larghezza delle ante da produrre.

It shows the measurement to follow between the leaf and the fixed frame in the production of windows depending on the typology, the hinge type and the width of the leaf to be produced.

			larghezza anta (cava ferramenta in mm) leaf width (hardware slot in mm)					
			280 360	361 480	481 600	601 800	> 800	
AR Easy DK Easy	AGE 271(2) AGE 271(2)-276(5) AGE 291(2) AGE 291(2)-296(5)	aria - gap	-	6	6	5,5	5	
		riscontro - strike	-	rid	rid	std	std	
	AGE 281(2) AGE 281(2)-286(5) AGE 281(2)-786(5)	aria - gap	-	5,5	5,5	5,5	5,5	
		riscontro - strike	-	rid	std	std	std	
	AGE 271(2)-776(5) AGE 291(2)-796(5)	aria - gap	-	6	6	6	5,5	
		riscontro - strike	-	rid	rid	std	std	
	AG 1273 AG 1278	aria - gap	-	6	6	5,5	5	
		riscontro - strike	-	rid	rid	std	std	
	AR RC2 DK RC2	AG 1271(2) AG 1271(2)-1276(5) AG 1291(2) AG 1291(2)-1296(5)	aria - gap	-	-	6	5,5	5
			riscontro - strike	-	-	std	std	std
AG 1281(2) AG 1281(2)-1286(5)		aria - gap	-	-	6	6	5,5	
		riscontro - strike	-	-	std	std	std	
Anta Casement	AGA 271 AGA 271-275 AGA 271-775	aria - gap	-	6	6	5,5	5	
		riscontro - strike	-	rid	rid	std	std	
	AGA 271-775	aria - gap	-	6	6	6	5,5	
		riscontro - strike	-	rid	rid	std	std	

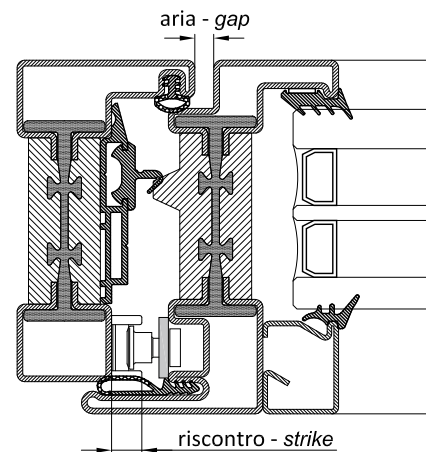

standard | standard
std = 8 mm

ribassato | reduced
rid = 5.5 mm

NB
gli incontri ribassati devono essere installati solamente sul lato cremonese
reduced strikes should be installed only on cremone vertical side

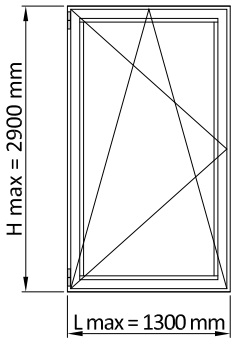

PROFILI		PROFILES			
Cod.	Descrizione	Description	n°	Dim.	Taglio Cutting
Telaio Frame					
PR1303	Profilo a "Z" telaio	"Z" profile frame	2	LS+44	45° 45°
PR1303	Profilo a "Z" telaio	"Z" profile frame	2	HS+44	45° 45°
Anta Leaf					
PR1333	Profilo a "Z" anta	"Z" profile frame	2	LS-34	45° 45°
PR1333	Profilo a "Z" anta	"Z" profile frame	2	HS-34	45° 45°
PR2027	Profilo battiacqua	Water drip profile	2	LS-104	90° 90°
Fermavetri Glazing beads					
PR2008	Fermavetro	Glazing bead profile	2	LS-130	90° 90°
PR2008	Fermavetro	Glazing bead profile	2	HS-170	90° 90°
Vetri Glass unit					
-	Vetrocamera	Insulated glass	1	LS-146 x HS-146	
ACCESSORI HARDWARE					
Cod.	Descrizione	Description	n°		
AC12031**	Kit squadrette per PR1203	Corner joint kit for PR1203	4		
AC12071**	Kit squadrette per PR1233	Corner joint kit for PR1233	4		
AC1716	Guarnizione d'angolo	Vulcanised corner gasket	4		
AC1219	Scarico acqua	Water drip	Var.		
AGE271/2..	Meccanismo Anta Ribalta	Tilt and Turn mechanism	1		
AG1271/C	Kit copertine plastica	Kit of RH plastic	1		
ACV97..	Maniglia "Vitruvio"	"Vitruvio" handle	1		
AC1356	Meccanismo DK	External tilt & turn mechanism	1		
AC1020	Supporto spessore vetro	Glass support	6		
CV5001(i)	Vite per boccola fermavetro	Screw for glazing bead bushing	Var.		
CV5012(i)	Boccola per fermavetro	Bushing for glazing bead	Var.		
GUARNIZIONI GASKETS					
Cod.	Descrizione	Description	n°	Dim.	
GE1233TT	Guarnizione esterna di battuta	External rebating gasket	1	2xLS+2xHS	
GE1701	Guarnizione giunto aperto	Open joint system gasket	1	2xLS+2xHS	
GU1302	Estruso PVC giunto aperto	Open joint system PVC profile	1	2xLS+2xHS	
GE1200TT	Guarnizione interna di battuta	Internal rebating gasket	1	2xLS+2xHS	
GE1206	Guarnizione esterna vetro	External gasket	1	2xLS+2xHS	
GE1007TT	Guarnizione sottovetro	Gasket to put under the glass	1	2xLS+2xHS	
GE..	Guarnizione interna vetro	Internal gasket	1	2xLS+2xHS	

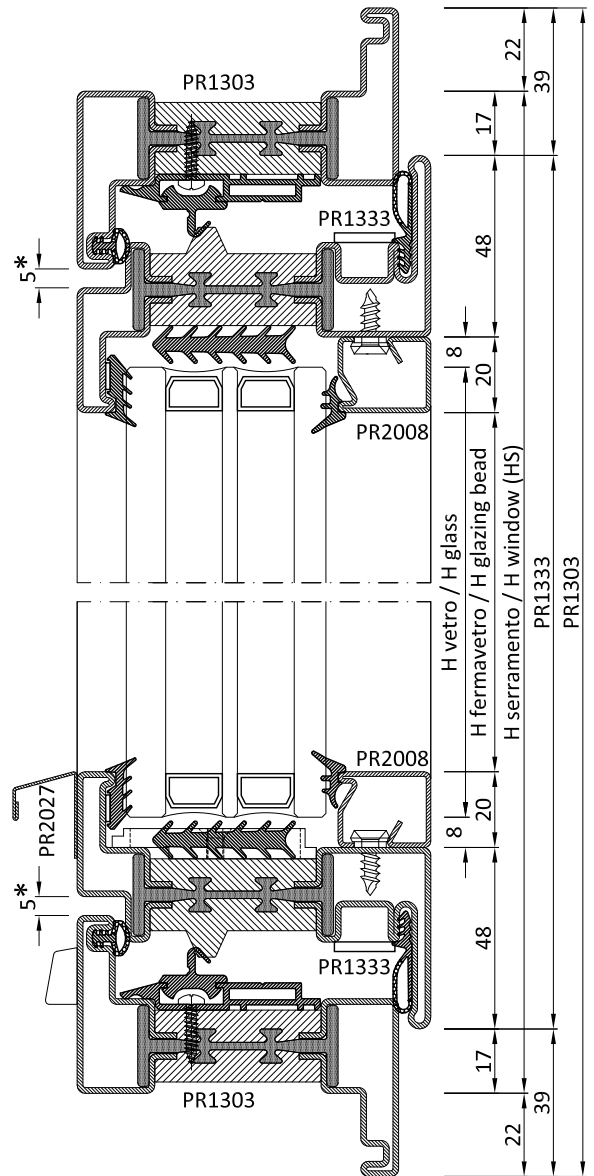

* vedi tabella 4.1.5
see chart 4.1.5

** solo con profili ottone
only with brass profiles

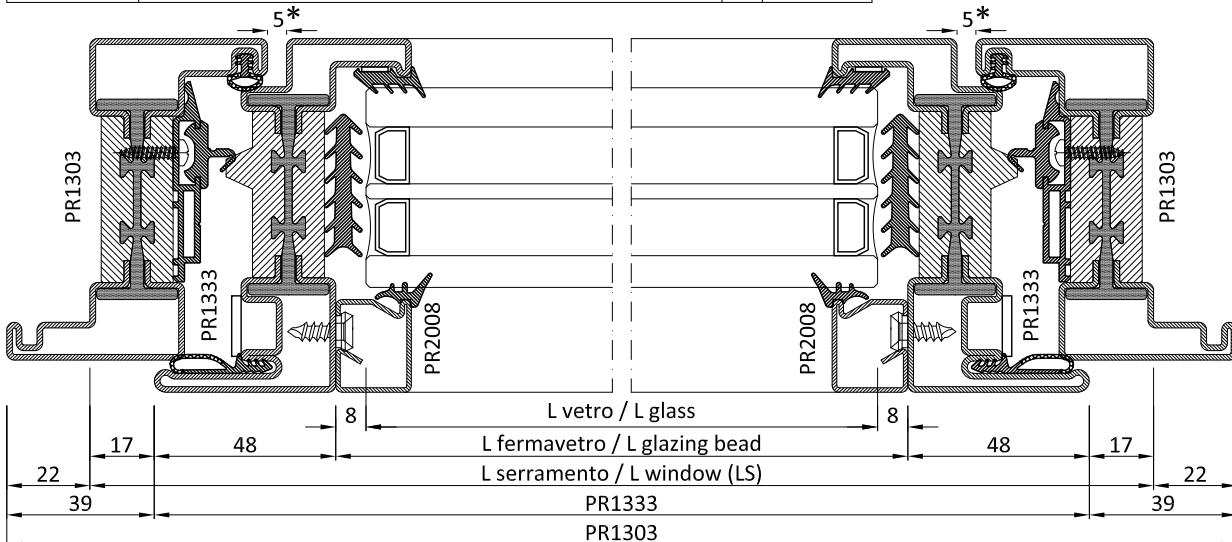

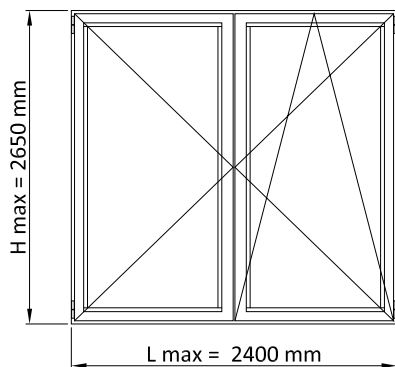

PROFILI		PROFILES				
Cod.	Descrizione	Description	n°	Dim.	Taglio	Cutting
Telaio		Frame				
PR1303	Profilo a "Z" telaio	"Z" profile frame	2	LS+44	45°	45°
PR1303	Profilo a "Z" telaio	"Z" profile frame	2	HS+44	45°	45°
Anta		Leaf				
PR1333	Profilo a "Z" anta	"Z" profile frame	4	(LS-43)/2	45°	45°
PR1333	Profilo a "Z" anta	"Z" profile frame	4	HS-34	45°	45°
PR1302	Profilo a "T" anta	"T" profile frame	1	HS-82.5	90°	90°
PR2027	Profilo battiacqua	Water drip profile	2	(LS-183)/2	90°	90°
Fermavetri		Glazing beads				
PR2008	Fermavetro	Glazing bead profile	4	(LS-235)/2	90°	90°
PR2008	Fermavetro	Glazing bead profile	4	HS-170	90°	90°
Vetri		Glass unit				
-	Vetrocamera	Insulated glass	2	[(LS-267)/2] x HS-146		

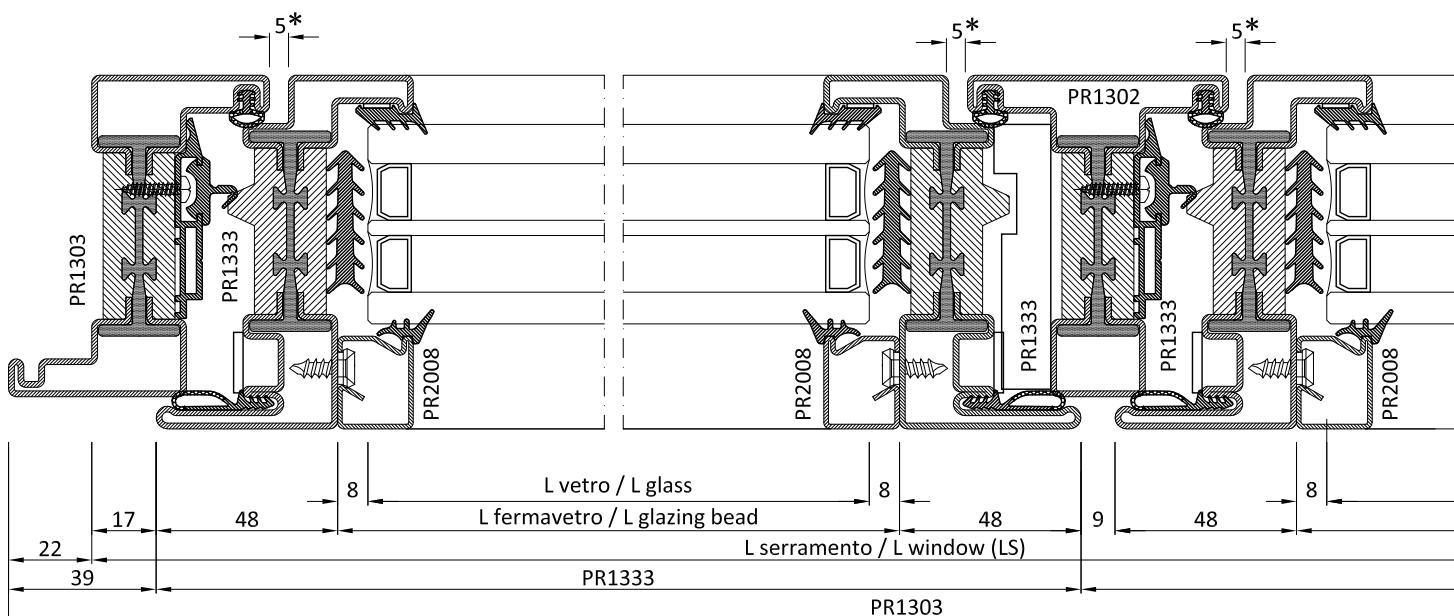

ACCESSORI		HARDWARE	
Cod.	Descrizione	Description	n°
AC12031**	Kit squadrette per PR1303	Corner joint kit for PR1303	4
AC12071**	Kit squadrette per PR1333	Corner joint kit for PR1333	8
AC1716	Guarnizione d'angolo	Vulcanised corner gasket	4
AC1219	Scarico acqua	Water drip	Var.
AC1355	Kit inversione battuta 2^ anta	2nd leaf reverse closure kit	2
AGE271/2..	Meccanismo Anta Ribalta 1^ anta	1st leaf tilt/turn mechanism	1
AGE275/6..	Meccanismo Anta Ribalta 2^ anta	2nd leaf tilt/turn mechanism	1
AG1271/C	Kit copertine plastica - dx	Kit of RH plastic - right	1
AG1272/C	Kit copertine plastica - sx	Kit of RH plastic - left	1
ACV97..	Maniglia "Vitruvio"	"Vitruvio" handle	1
AC1356	Meccanismo DK	External tilt & turn mechanism	1
AC1020	Supporto spessore vetro	Glass support	12
CV5001(i)	Vite per boccola fermavetro	Screw for glazing bead bushing	Var.
CV5012(i)	Boccola per fermavetro	Bushing for glazing bead	Var.

GUARNIZIONI		GASKETS		
Cod.	Descrizione	Description	n°	Dim.
GE1233TT	Guarnizione esterna di battuta	External rebating gasket	1	2xLS+4xHS
GE1701	Guarnizione giunto aperto	Open joint system gasket	1	2xLS+3xHS
GU1302	Estruso PVC giunto aperto	Open joint system PVC profile	1	2xLS+3xHS
GE1200TT	Guarnizione interna di battuta	Internal rebating gasket	1	2xLS+4xHS
GE1206	Guarnizione esterna vetro	External gasket	1	2xLS+4xHS
GE1007TT	Guarnizione sottovetro	Gasket to put under the glass	1	2xLS+4xHS
GE..	Guarnizione interna vetro	Internal gasket	1	2xLS+4xHS

* vedi tabella 4.1.5
see chart 4.1.5

** solo con profili ottone
only with brass profiles

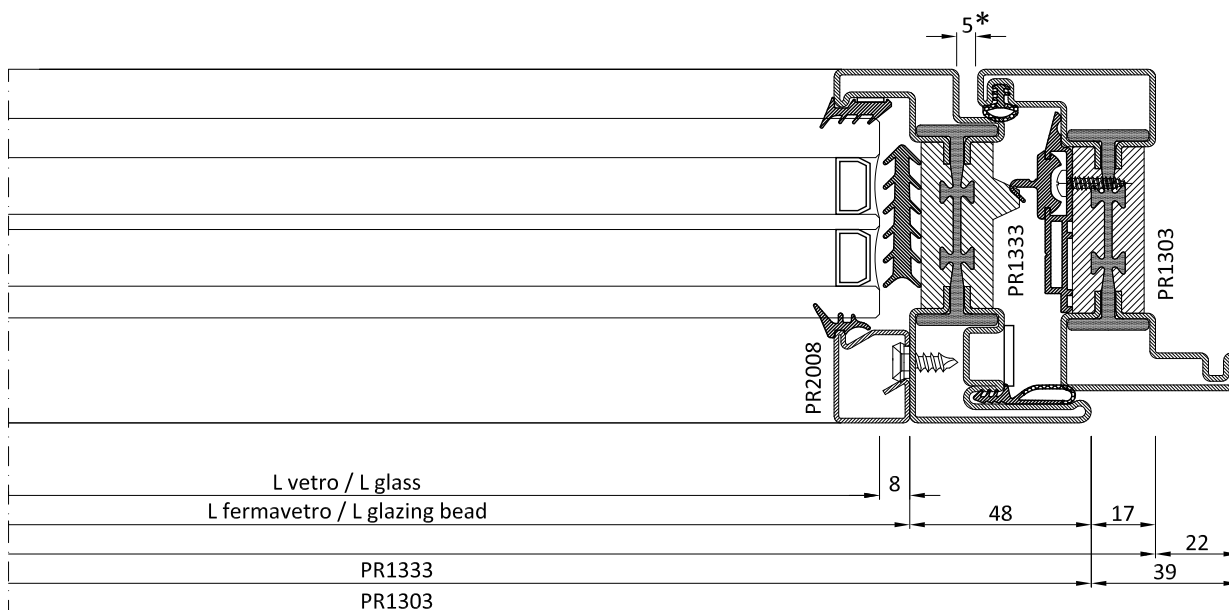
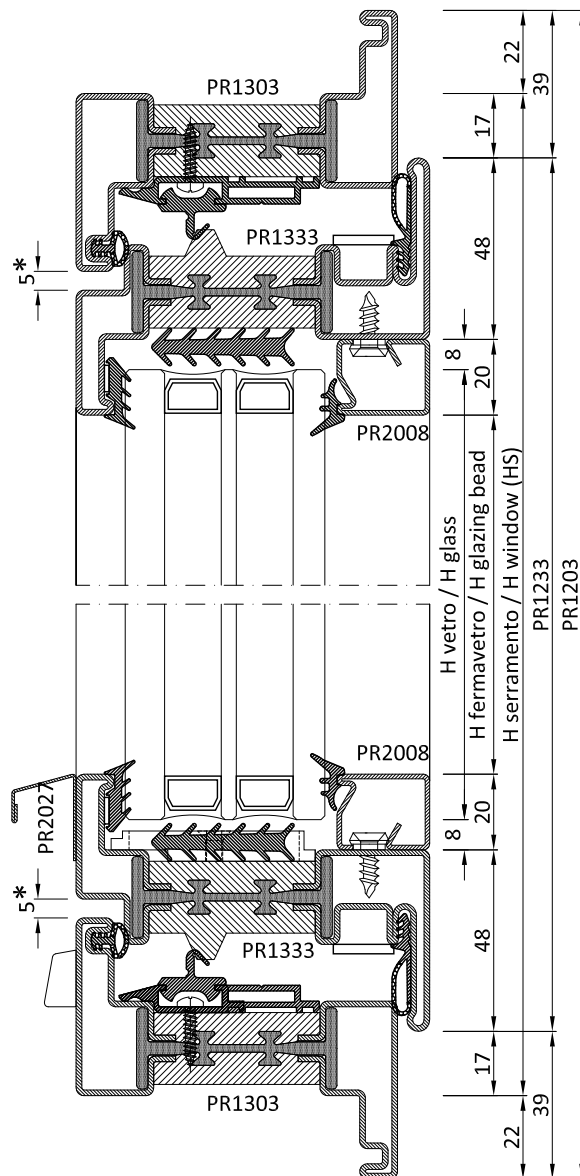

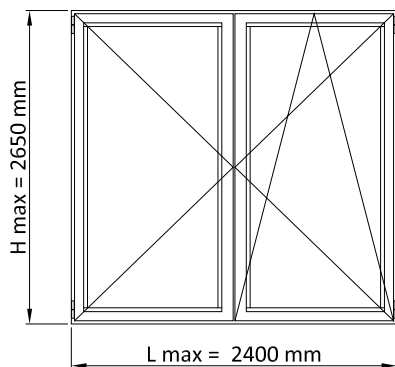

PROFILI		PROFILES				
Cod.	Descrizione	Description	n°	Dim.	Taglio	Cutting
Telaio		Frame				
PR1303	Profilo a "Z" telaio	"Z" profile frame	2	LS+44	45°	45°
PR1303	Profilo a "Z" telaio	"Z" profile frame	2	HS+44	45°	45°
Anta		Leaf				
PR1333	Profilo a "Z" anta	"Z" profile frame	4	(LS-5)/2	45°	45°
PR1333	Profilo a "Z" anta	"Z" profile frame	3	HS-34	45°	45°
PR1924	Profilo a "T" anta	"T" profile frame	1	HS-32	45°	45°
PR2027	Profilo battiacqua	Water drip profile	1	(LS-75)/2	90°	90°
PR2027	Profilo battiacqua	Water drip profile	2	(LS-143)/2	90°	90°
Fermavetri		Glazing beads				
PR2008	Fermavetro	Glazing bead profile	4	(LS-197)/2	90°	90°
PR2008	Fermavetro	Glazing bead profile	4	HS-170	90°	90°
Vetri		Glass unit				
-	Vetrocamera	Insulated glass	2	[(LS-229)/2] x HS-146		

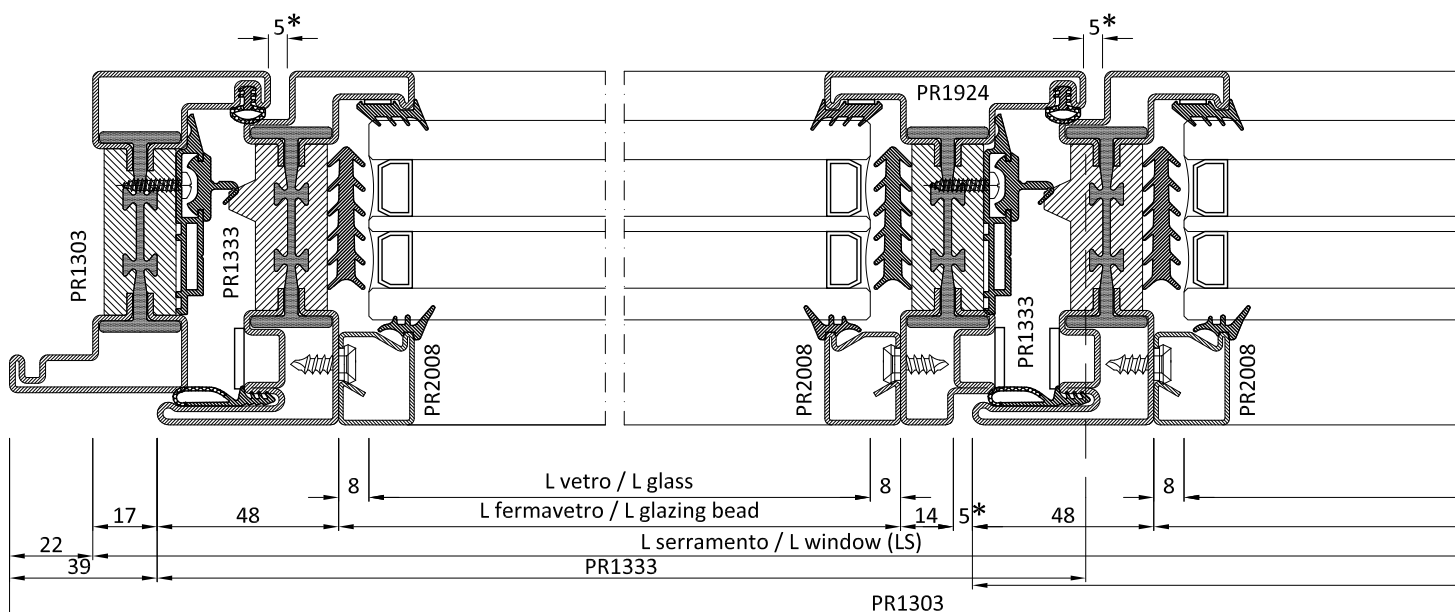

ACCESSORI		HARDWARE	
Cod.	Descrizione	Description	n°
AC12031**	Kit squadrette per PR1303	Corner joint kit for PR1303	4
AC12071**	Kit squadrette per PR1333	Corner joint kit for PR1333	6
AC17081**	Kit squadrette per PR1333-1924	Corner joint kit for PR1333-1924	2
AC1716	Guarnizione d'angolo	Vulcanised corner gasket	4
AC1219	Scarico acqua	Water drip	Var.
AC1714	Kit inversione battuta 2^ anta	2nd leaf reverse closure kit	1
AGE271/2..	Meccanismo Anta Ribalta 1^ anta	1st leaf tilt/turn mechanism	1
AGE775/6..	Meccanismo Anta Ribalta 2^ anta	2nd leaf tilt/turn mechanism	1
AG1271/C	Kit copertine plastica - dx	Kit of RH plastic - right	1
AG1272/C	Kit copertine plastica - sx	Kit of RH plastic - left	1
ACV97..	Maniglia "Vitruvio"	"Vitruvio" handle	1
AC1356	Meccanismo DK	External tilt & turn mechanism	1
AC1020	Supporto spessore vetro	Glass support	12
CV5001(i)	Vite per boccola fermavetro	Screw for glazing bead bushing	Var.
CV5012(i)	Boccola per fermavetro	Bushing for glazing bead	Var.

GUARNIZIONI		GASKETS	
Cod.	Descrizione	Description	n° Dim.
GE1233TT	Guarnizione esterna di battuta	External rebating gasket	1 2xLS+3xHS
GE1701	Guarnizione giunto aperto	Open joint system gasket	1 2xLS+3xHS
GE1704	Guarnizione giunto aperto PR1924	Open joint system gasket PR1924	1 1xHS
GU1302	Estruso PVC giunto aperto	Open joint system PVC profile	1 2xLS+3xHS
GE1200TT	Guarnizione interna di battuta	Internal rebating gasket	1 2xLS+3xHS
GE1206	Guarnizione esterna vetro	External gasket	1 2xLS+4xHS
GE1007TT	Guarnizione sottovetro	Gasket to put under the glass	1 2xLS+4xHS
GE..	Guarnizione interna vetro	Internal gasket	1 2xLS+4xHS

* vedi tabella 4.1.5
see chart 4.1.5

** solo con profili ottone
only with brass profiles

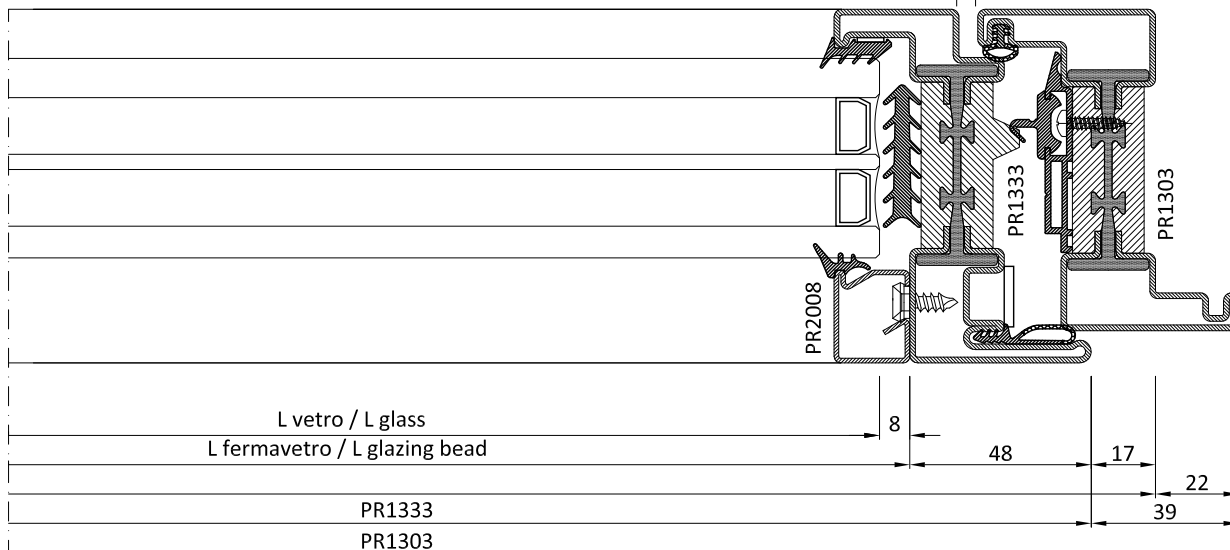
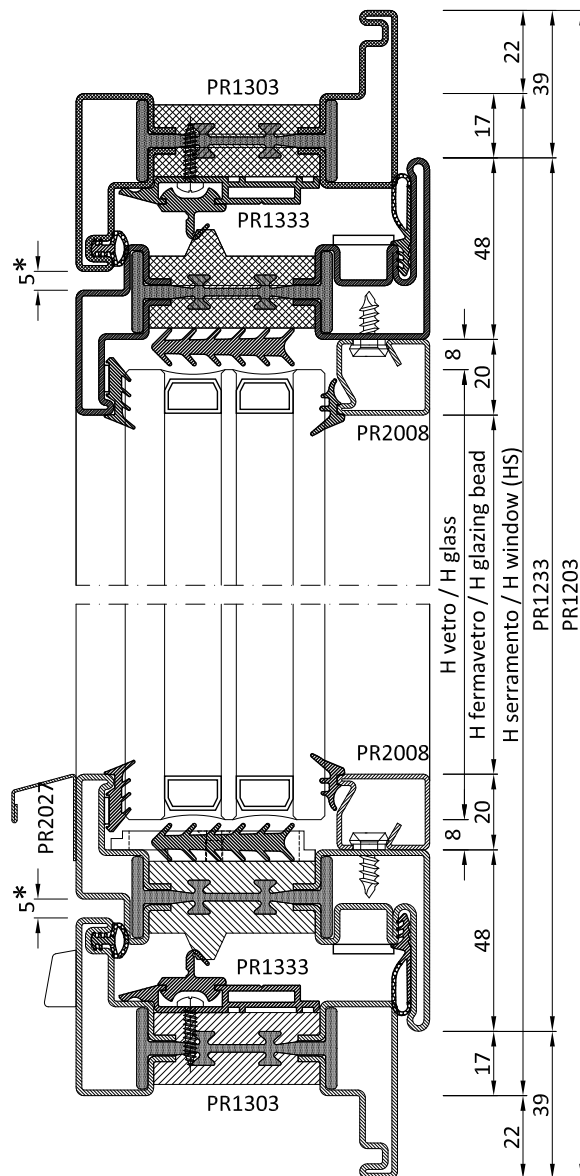

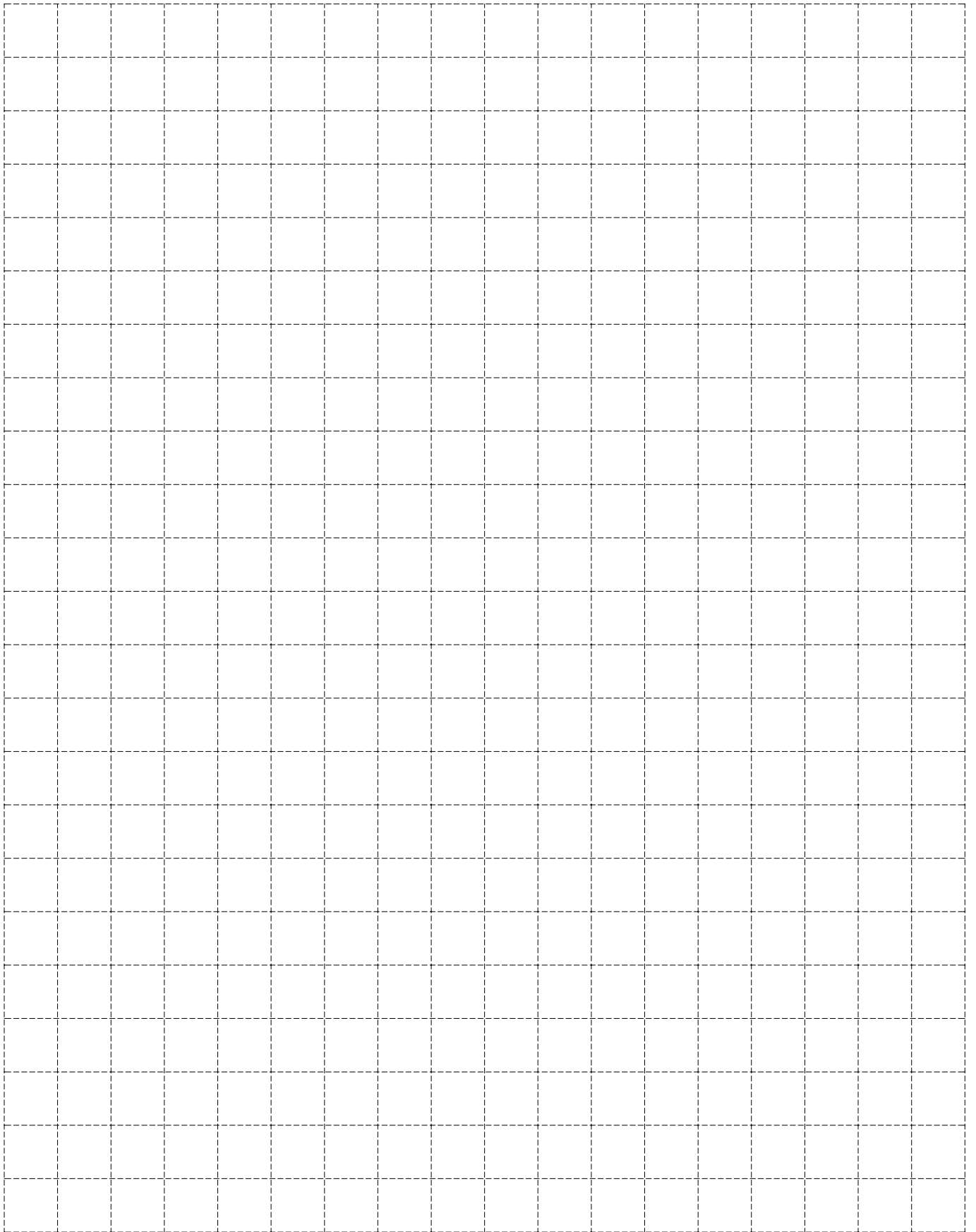

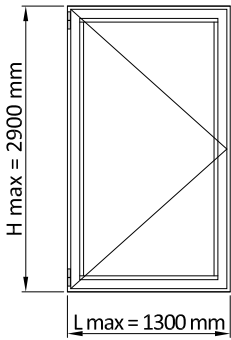

PROFILFI		PROFILES		n°	Dim.	Taglio	Cutting
Cod.	Descrizione	Description					
Telaio				Frame			
PR1303	Profilo a "Z" telaio	"Z" profile frame	2	LS+44	45°	45°	
PR1303	Profilo a "Z" telaio	"Z" profile frame	2	HS+44	45°	45°	
Anta				Leaf			
PR1333	Profilo a "Z" anta	"Z" profile frame	2	LS-34	45°	45°	
PR1333	Profilo a "Z" anta	"Z" profile frame	2	HS-34	45°	45°	
PR2027	Profilo battiacqua	Water drip profile	2	LS-104	90°	90°	
Fermavetri				Glazing beads			
PR2008	Fermavetro	Glazing bead profile	2	LS-130	90°	90°	
PR2008	Fermavetro	Glazing bead profile	2	HS-170	90°	90°	
Vetri				Glass unit			
-	Vetrocamera	Insulated glass	1	LS-146 x HS-146			
ACCESSORI		HARDWARE					
Cod.	Descrizione	Description	n°				
AC12031**	Kit squadrette per PR1303	Corner joint kit for PR1303	4				
AC12071**	Kit squadrette per PR1333	Corner joint kit for PR1333	4				
AC1716	Guarnizione d'angolo	Vulcanised corner gasket	4				
AC1219	Scarico acqua	Water drip	Var.				
AC1237	Cerniera ad avvitare	Screw-on hinge	Var.				
AGA271..	Meccanismo apertura ad anta	Casement window mechanism	1				
ACV97..	Maniglia "Vitruvio"	"Vitruvio" handle	1				
AC1356	Meccanismo DK	External tilt & turn mechanism	1				
AC1020	Supporto spessore vetro	Glass support	6				
CV5001(i)	Vite per boccola fermavetro	Screw for glazing bead bushing	Var.				
CV5012(i)	Boccola per fermavetro	Bushing for glazing bead	Var.				
GUARNIZIONI		GASKETS					
Cod.	Descrizione	Description	n°	Dim.			
GE1233TT	Guarnizione esterna di battuta	External rebating gasket	1	2xLS+2xHS			
GE1701	Guarnizione giunto aperto	Open joint system gasket	1	2xLS+2xHS			
GU1302	Estruso PVC giunto aperto	Open joint system PVC profile	1	2xLS+2xHS			
GE1200TT	Guarnizione interna di battuta	Internal rebating gasket	1	2xLS+2xHS			
GE1206	Guarnizione esterna vetro	External gasket	1	2xLS+2xHS			
GE1007TT	Guarnizione sottovetro	Gasket to put under the glass	1	2xLS+2xHS			
GE..	Guarnizione interna vetro	Internal gasket	1	2xLS+2xHS			

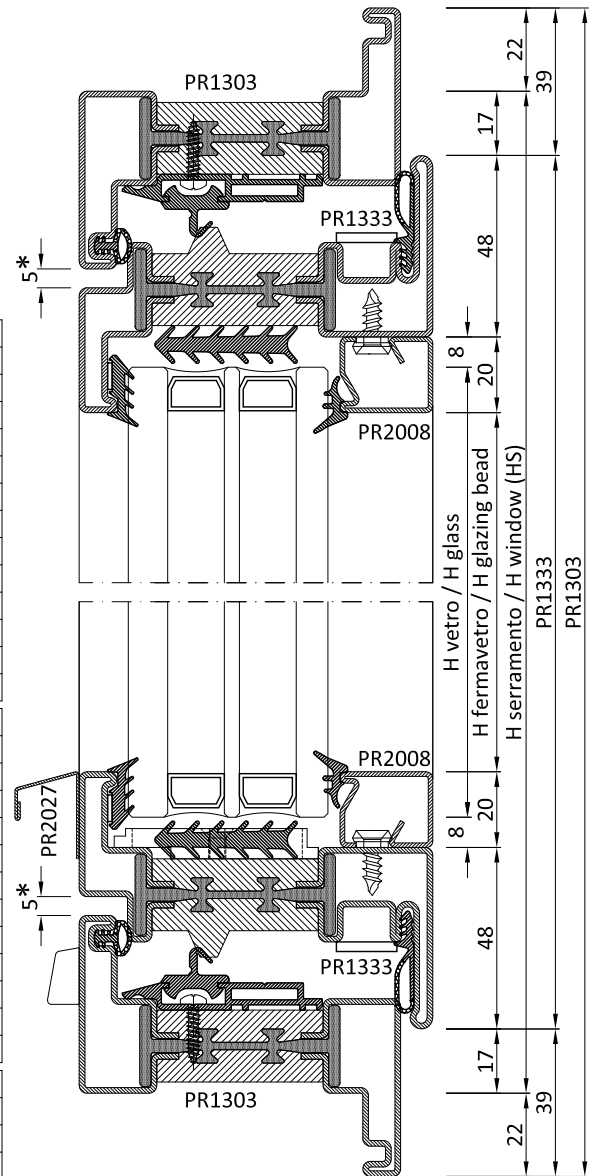

* vedi tabella 4.1.5
see chart 4.1.5

** solo con profili ottone
only with brass profiles

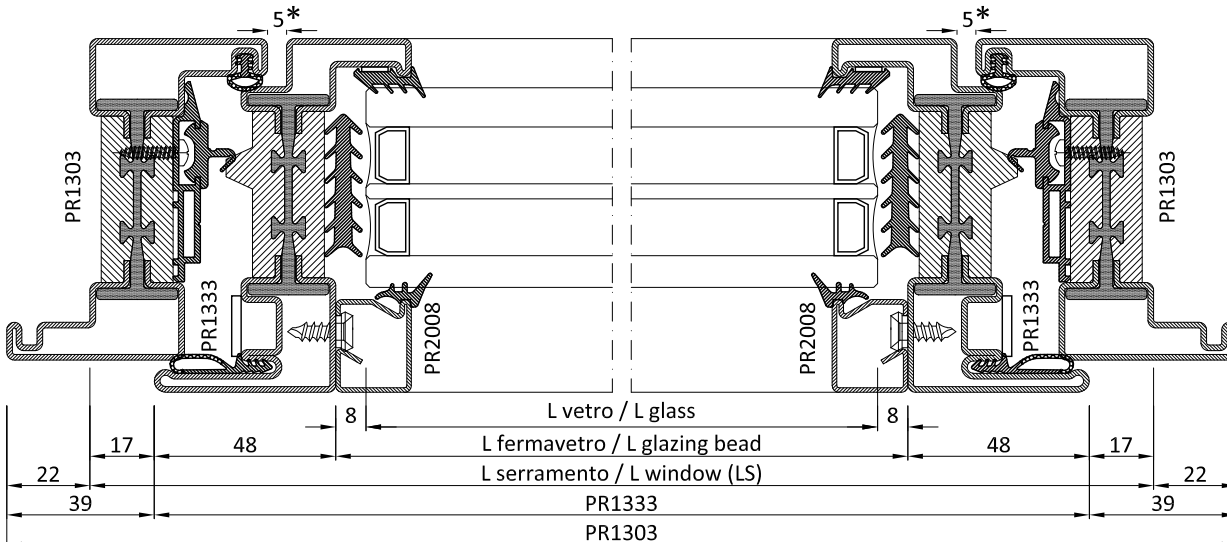

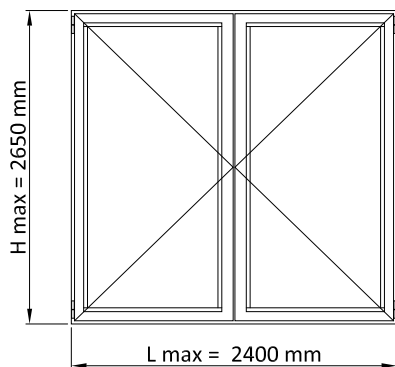

PROFILI		PROFILES				
Cod.	Descrizione	Description	n°	Dim.	Taglio	Cutting
Telaio		Frame				
PR1303	Profilo a "Z" telaio	"Z" profile frame	2	LS+44	45°	45°
PR1303	Profilo a "Z" telaio	"Z" profile frame	2	HS+44	45°	45°
Anta		Leaf				
PR1333	Profilo a "Z" anta	"Z" profile frame	4	(LS-43)/2	45°	45°
PR1333	Profilo a "Z" anta	"Z" profile frame	4	HS-34	45°	45°
PR1302	Profilo a "T" anta	"T" profile frame	1	HS-82.5	90°	90°
PR2027	Profilo battiacqua	Water drip profile	2	(LS-183)/2	90°	90°
Fermavetri		Glazing beads				
PR2008	Fermavetro	Glazing bead profile	4	(LS-235)/2	90°	90°
PR2008	Fermavetro	Glazing bead profile	4	HS-170	90°	90°
Vetri		Glass unit				
-	Vetrocamera	Insulated glass	2	[(LS-267)/2] x HS-146		

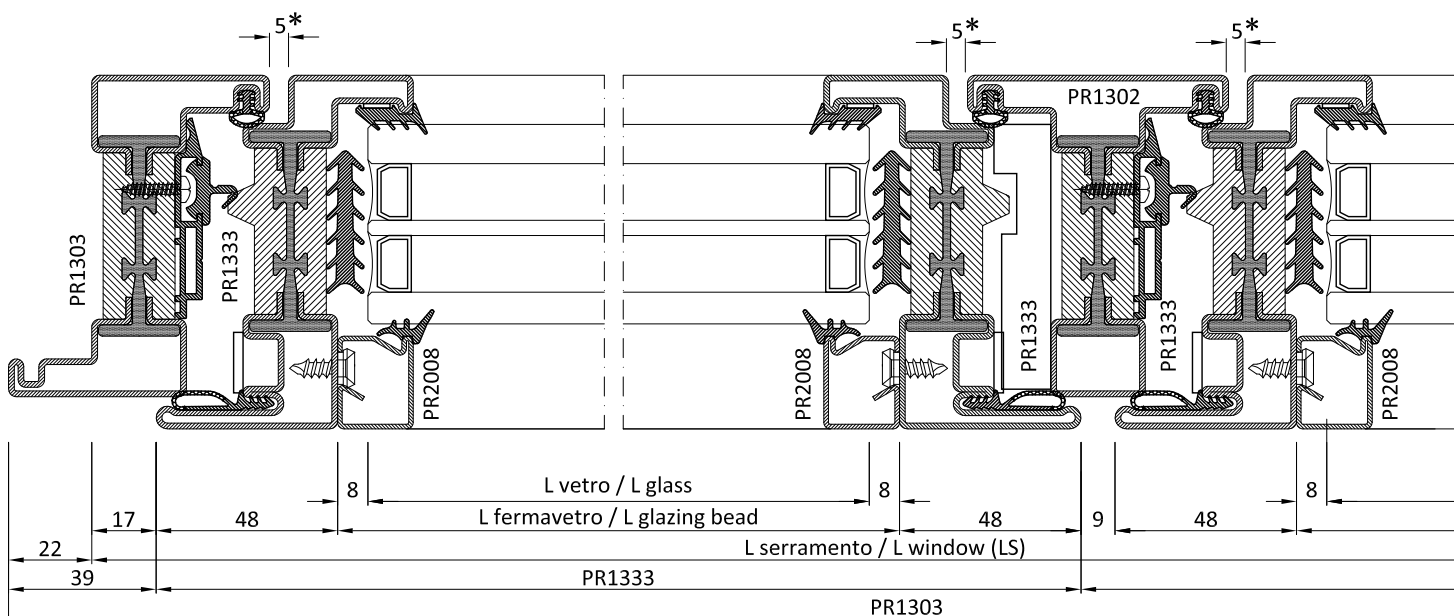

ACCESSORI		HARDWARE	
Cod.	Descrizione	Description	n°
AC1203**	Kit squadrette per PR1303	Corner joint kit for PR1303	4
AC1207**	Kit squadrette per PR1333	Corner joint kit for PR1333	8
AC1716	Guarnizione d'angolo	Vulcanised corner gasket	4
AC1219	Scarico acqua	Water drip	Var.
AC1355	Kit inversione battuta 2 ^a anta	2nd leaf reverse closure kit	2
AC1237	Cerniera ad avvitare	Screw-on hinge	Var.
AGA271..	Meccanismo apertura 1 ^a anta	1st leaf opening mechanism	1
AGA275..	Meccanismo apertura 2 ^a anta	2nd leaf opening mechanism	1
ACV97..	Maniglia "Vitruvio"	"Vitruvio" handle	1
AC1356	Meccanismo DK	External tilt & turn mechanism	1
AC1020	Supporto spessore vetro	Glass support	12
CV5001(i)	Vite per boccola fermavetro	Screw for glazing bead bushing	Var.
CV5012(i)	Boccola per fermavetro	Bushing for glazing bead	Var.

GUARNIZIONI		GASKETS		
Cod.	Descrizione	Description	n°	Dim.
GE1233TT	Guarnizione esterna di battuta	External rebating gasket	1	2xLS+4xHS
GE1701	Guarnizione giunto aperto	Open joint system gasket	1	2xLS+3xHS
GU1302	Estruso PVC giunto aperto	Open joint system PVC profile	1	2xLS+3xHS
GE1200TT	Guarnizione interna di battuta	Internal rebating gasket	1	2xLS+4xHS
GE1206	Guarnizione esterna vetro	External gasket	1	2xLS+4xHS
GE1007TT	Guarnizione sottovetro	Gasket to put under the glass	1	2xLS+4xHS
GE..	Guarnizione interna vetro	Internal gasket	1	2xLS+4xHS

* vedi tabella 4.1.5
see chart 4.1.5

** solo con profili ottone
only with brass profiles

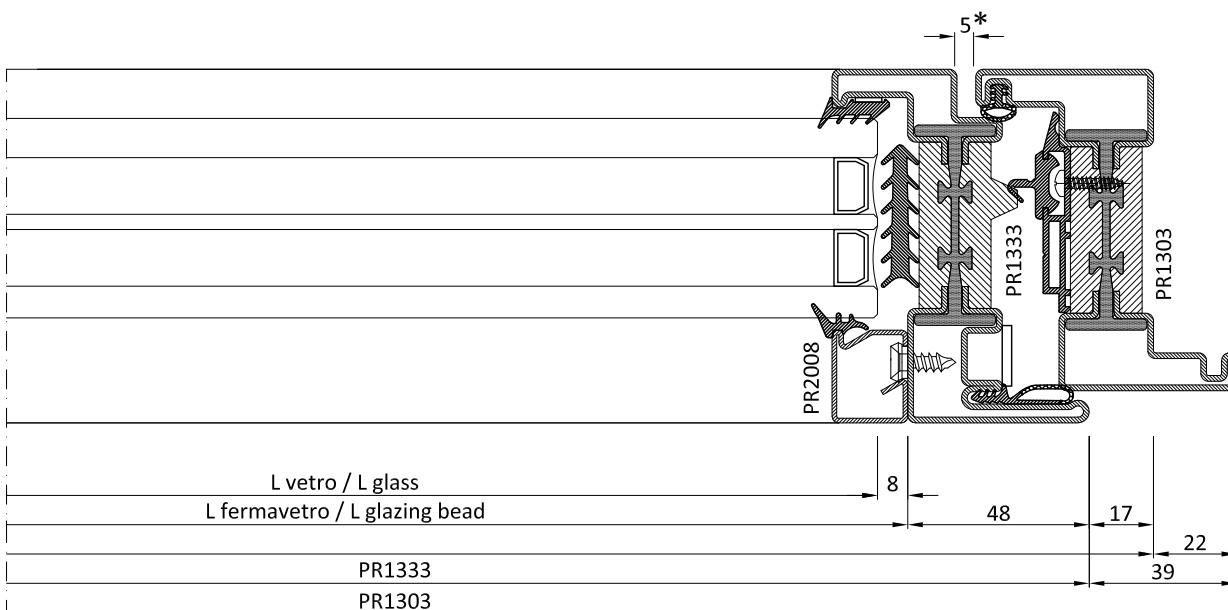
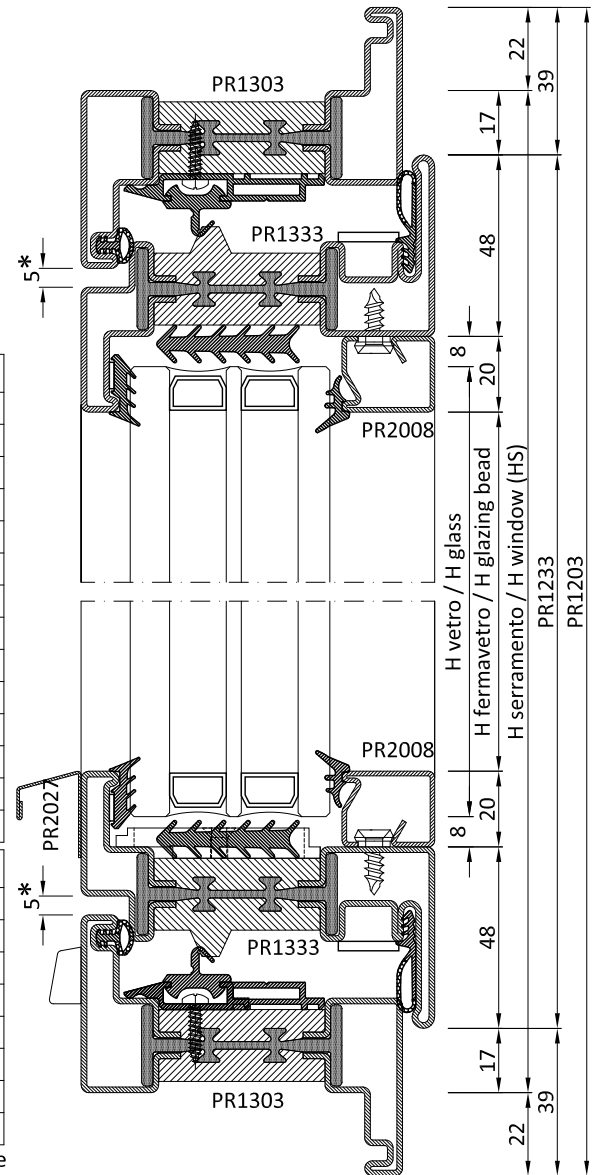

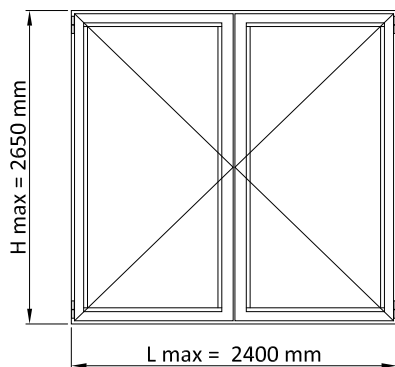

PROFILI		PROFILES				
Cod.	Descrizione	Description	n°	Dim.	Taglio Cutting	
Telaio		Frame				
PR1303	Profilo a "Z" telaio	"Z" profile frame	2	LS+44	45°	45°
PR1303	Profilo a "Z" telaio	"Z" profile frame	2	HS+44	45°	45°
Anta		Leaf				
PR1333	Profilo a "Z" anta	"Z" profile frame	4	(LS-5)/2	45°	45°
PR1333	Profilo a "Z" anta	"Z" profile frame	3	HS-34	45°	45°
PR1924	Profilo a "T" anta	"T" profile frame	1	HS-32	45°	45°
PR2027	Profilo battiacqua	Water drip profile	1	(LS-75)/2	90°	90°
PR2027	Profilo battiacqua	Water drip profile	2	(LS-143)/2	90°	90°
Fermavetri		Glazing beads				
PR2008	Fermavetro	Glazing bead profile	4	(LS-197)/2	90°	90°
PR2008	Fermavetro	Glazing bead profile	4	HS-170	90°	90°
Vetri		Glass unit				
-	Vetrocamera	Insulated glass	2	[(LS-229)/2] x HS-146		

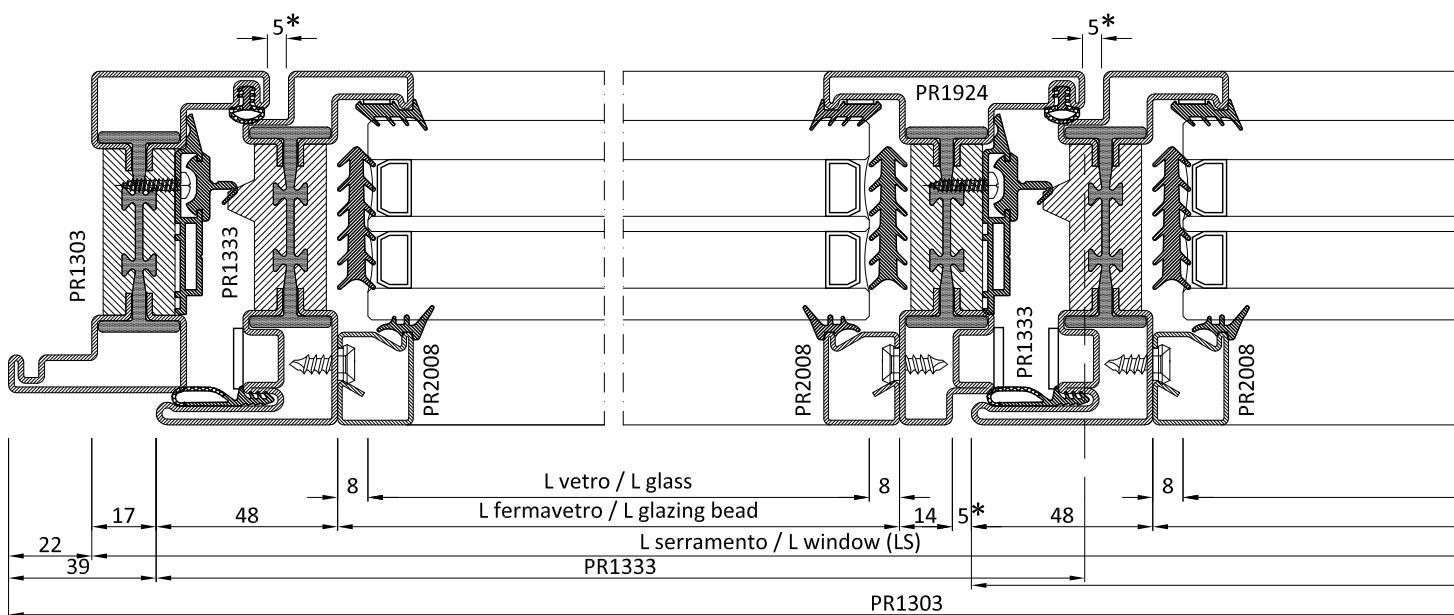

ACCESSORI		HARDWARE	
Cod.	Descrizione	Description	n°
AC12031**	Kit squadrette per PR1303	Corner joint kit for PR1303	4
AC12071**	Kit squadrette per PR1333	Corner joint kit for PR1333	6
AC17081**	Kit squadrette per PR1333-1924	Corner joint kit for PR1333-1924	2
AC1716	Guarnizione d'angolo	Vulcanised corner gasket	4
AC1219	Scarico acqua	Water drip	Var.
AC1714	Kit inversione battuta 2 ^a anta	2nd leaf reverse closure kit	1
AC1237	Cerniera ad avvitare	Screw-on hinge	Var.
AGA271..	Meccanismo apertura 1 ^a anta	1st leaf opening mechanism	1
AGA775..	Meccanismo apertura 2 ^a anta	2nd leaf opening mechanism	1
ACV97..	Maniglia "Vitruvio"	"Vitruvio" handle	1
AC1356	Meccanismo DK	External tilt & turn mechanism	1
AC1020	Supporto spessore vetro	Glass support	12
CV5001(i)	Vite per boccola fermavetro	Screw for glazing bead bushing	Var.
CV5012(i)	Boccola per fermavetro	Bushing for glazing bead	Var.

GUARNIZIONI		GASKETS		
Cod.	Descrizione	Description	n°	Dim.
GE1233TT	Guarnizione esterna di battuta	External rebating gasket	1	2xLS+3xHS
GE1701	Guarnizione giunto aperto	Open joint system gasket	1	2xLS+3xHS
GE1704	Guarnizione giunto aperto PR1924	Open joint system gasket PR1924	1	1xHS
GU1302	Estruso PVC giunto aperto	Open joint system PVC profile	1	2xLS+3xHS
GE1200TT	Guarnizione interna di battuta	Internal rebating gasket	1	2xLS+3xHS
GE1206	Guarnizione esterna vetro	External gasket	1	2xLS+4xHS
GE1007TT	Guarnizione sottovetro	Gasket to put under the glass	1	2xLS+4xHS
GE..	Guarnizione interna vetro	Internal gasket	1	2xLS+4xHS

* vedi tabella 4.1.5
see chart 4.1.5

** solo con profili ottone
only with brass profiles

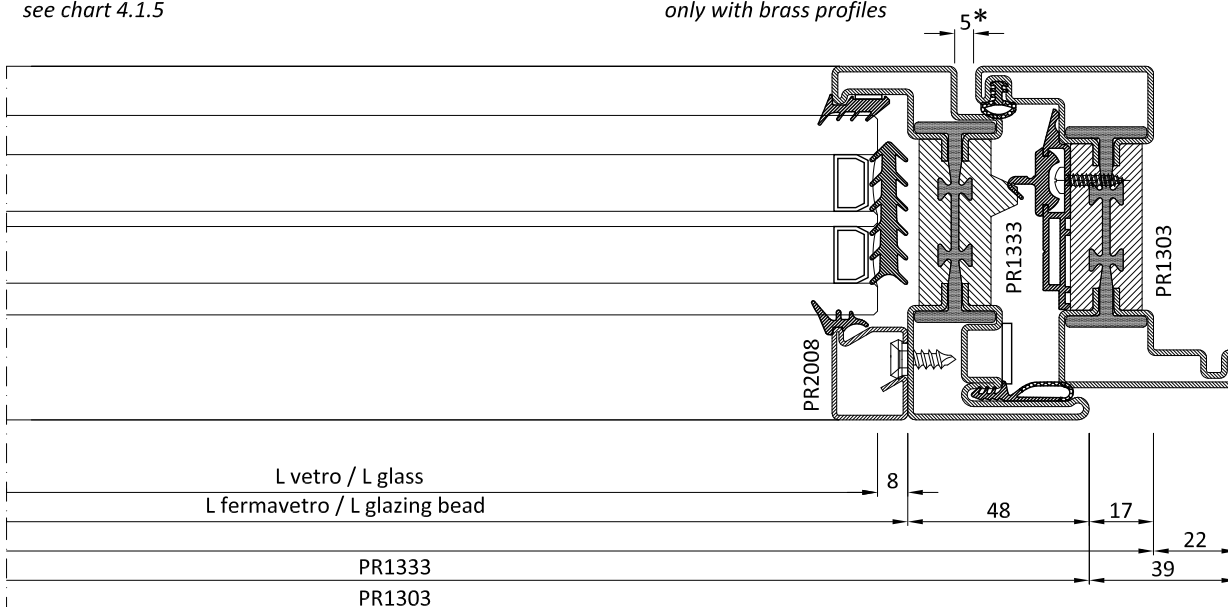
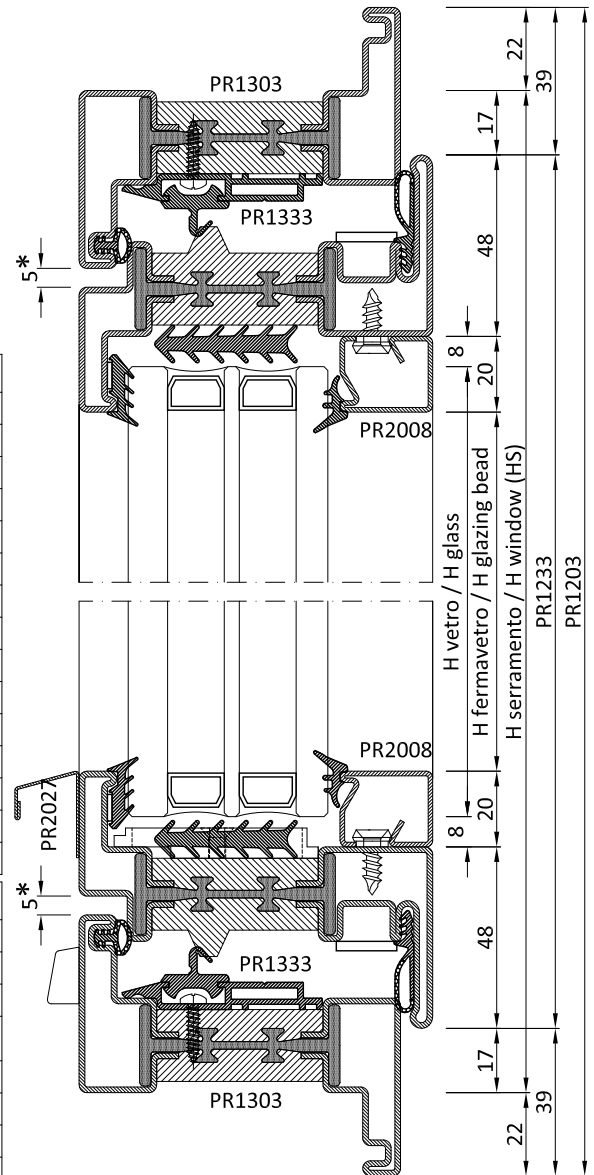

Distinta di taglio e lista componenti | Cutting list and components list

Le distinte di taglio e le liste accessori individuate per le diverse tipologie sono state redatte per un serramento tipo.

E' compito dei tecnici specializzati delle ditte produttrici analizzare criticamente tali indicazioni al fine di verificare la compatibilità del tipo e numero di accessori previsti con il serramento oggetto della commessa reale.

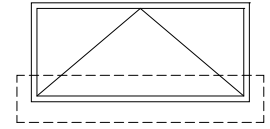

The cutting and hardware lists, which have been identified for the different typologies, have been produced for a standard window.

The specialized technicians of the window manufacturers will have to critically analyze such information in order to verify the compatibility of both the type and the number of accessories provided with the window object of the real order.

La tabella seguente va attentamente letta prima del taglio dei profili | The following table should be carefully read before the profiles cutting

In essa è riportata la misura da considerare nella distanza tra telaio anta e telaio fisso nella produzione di finestre in funzione della tipologia, del tipo di cerniera e della larghezza delle ante da produrre.

It shows the measurement to follow between the leaf and the fixed frame in the production of windows depending on the typology, the hinge type and the width of the leaf to be produced.

			larghezza anta (cava ferramenta in mm) leaf width (hardware slot in mm)	
			< 480	> 480
Vasistas	AG 1264	aria - gap	6	5
Bottom hung	AG 1274	riscontro - strike	std	std

NB
gli incontri ribassati devono essere installati solamente sul lato cremonese
reduced strikes should be installed only on cremone vertical side

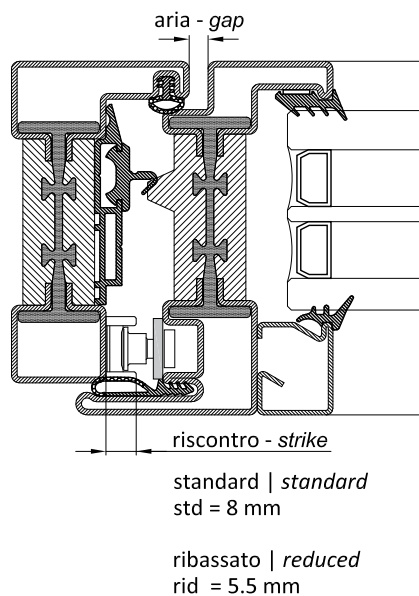

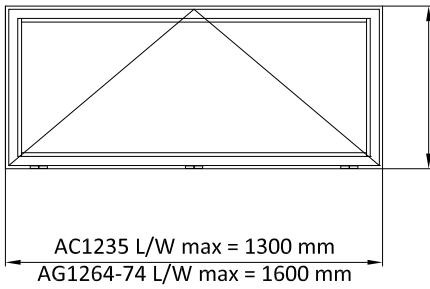

AC1235 H max = 800 mm
AG1264-74 H max = 1200 mm

PROFILI		PROFILES			
Cod.	Descrizione	Description	n°	Dim.	Taglio Cutting
Telaio Frame					
PR1303	Profilo a "Z" telaio	"Z" profile frame	2	LS+44	45° 45°
PR1303	Profilo a "Z" telaio	"Z" profile frame	2	HS+44	45° 45°
Anta Leaf					
PR1333	Profilo a "Z" anta	"Z" profile frame	2	LS-34	45° 45°
PR1333	Profilo a "Z" anta	"Z" profile frame	2	HS-34	45° 45°
PR2027	Profilo battiacqua	Water drip profile	2	LS-104	90° 90°
Fermavetri Glazing beads					
PR2008	Fermavetro	Glazing bead profile	2	LS-130	90° 90°
PR2008	Fermavetro	Glazing bead profile	2	HS-170	90° 90°
Vetri Glass unit					
-	Vetrocamera	Insulated glass	1	LS-146 x HS-146	
ACCESSORI		HARDWARE			
Cod.	Descrizione	Description	n°		
AC1203I**	Kit squadrette per PR1303	Corner joint kit for PR1303	4		
AC1207I**	Kit squadrette per PR1333	Corner joint kit for PR1333	4		
AC1716	Guarnizione d'angolo	Vulcanised corner gasket	4		
AC1219	Scarico acqua	Water drip	Var.		
AC../AG..	Cerniere	Hinges	2/3		
AG1264/74..	Meccanismo Vasistas	Bottom hung mechanism	1		
ACV97..	Maniglia "Vitruvio"	"Vitruvio" handle	1		
AC1356	Meccanismo DK	External tilt & turn mechanism	1		
AC1020	Supporto spessore vetro	Glass support	6		
CV5001(i)	Vite per boccola fermavetro	Screw for glazing bead bushing	Var.		
CV5012(i)	Boccola per fermavetro	Bushing for glazing bead	Var.		
GUARNIZIONI		GASKETS			
Cod.	Descrizione	Description	n°	Dim.	
GE1233TT	Guarnizione esterna di battuta	External rebating gasket	1	2xLS+2xHS	
GE1701	Guarnizione giunto aperto	Open joint system gasket	1	2xLS+2xHS	
GU1702	Estruso PVC giunto aperto	Open joint system PVC profile	1	2xLS+2xHS	
GE1200TT	Guarnizione interna di battuta	Internal rebating gasket	1	2xLS+2xHS	
GE1206	Guarnizione esterna vetro	External gasket	1	2xLS+2xHS	
GE1007TT	Guarnizione sottovetro	Gasket to put under the glass	1	2xLS+2xHS	
GE..	Guarnizione interna vetro	Internal gasket	1	2xLS+2xHS	

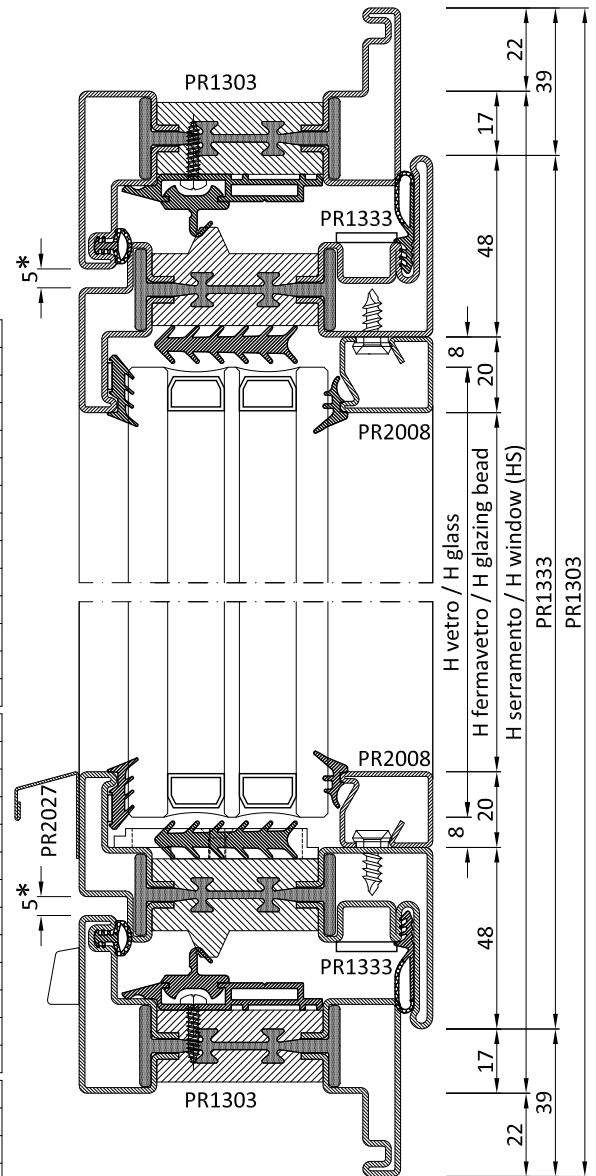

* vedi tabella 4.1.16
see chart 4.1.16

** solo con profili ottone
only with brass profiles

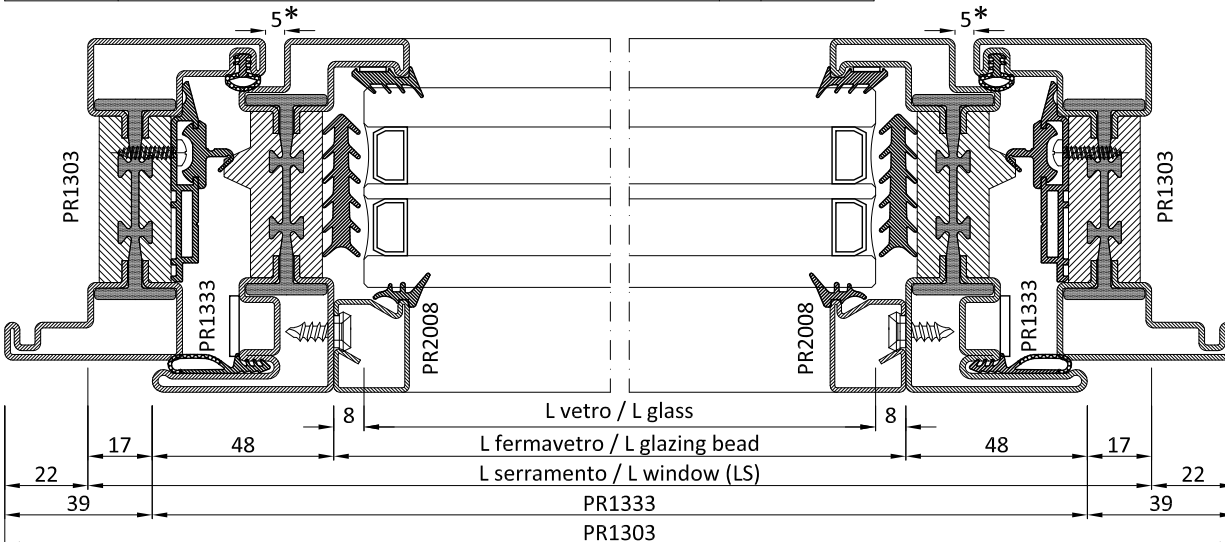

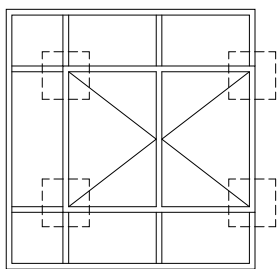
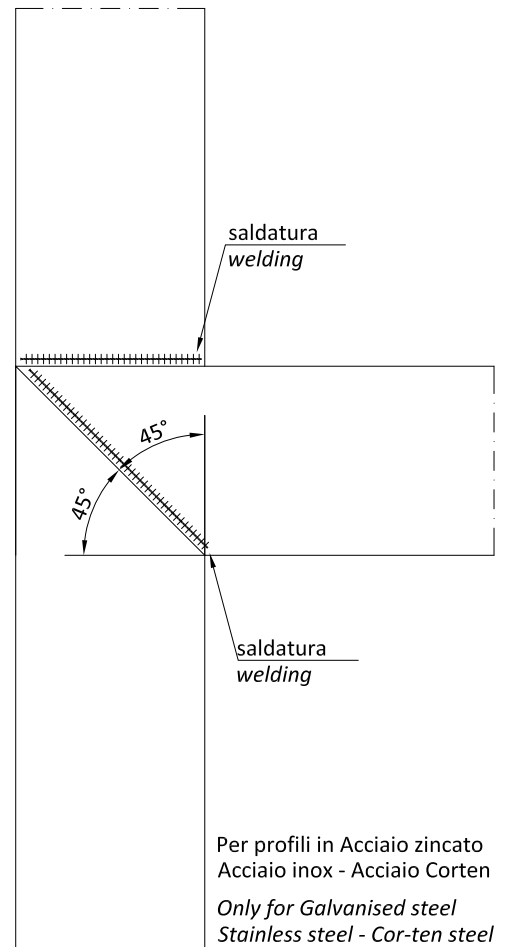
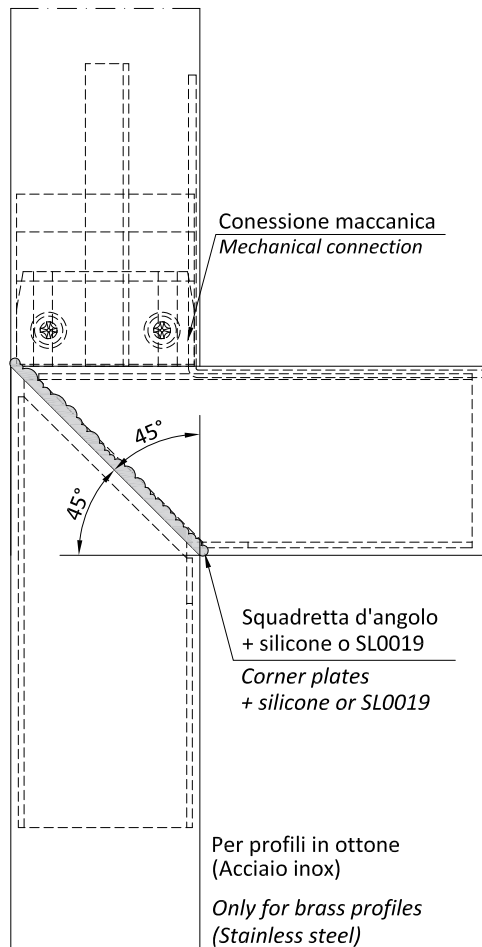
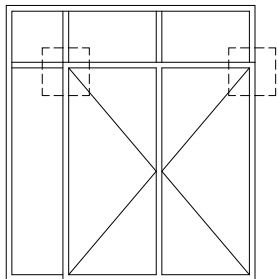
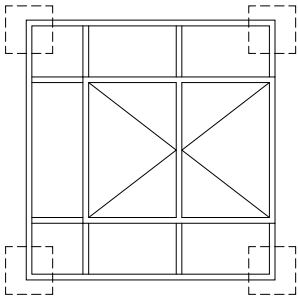
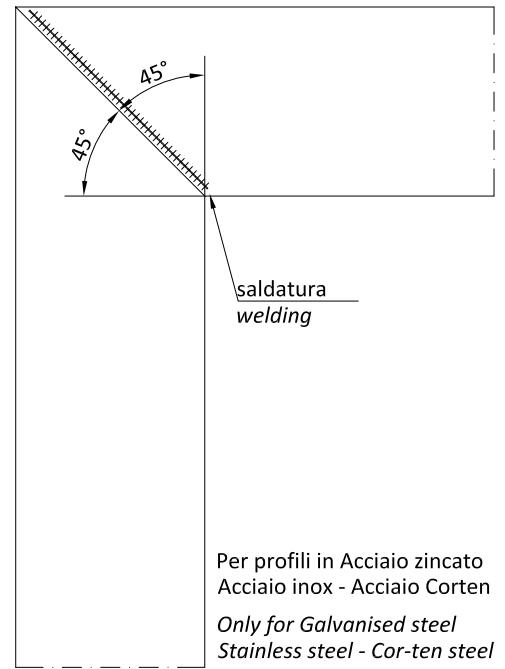
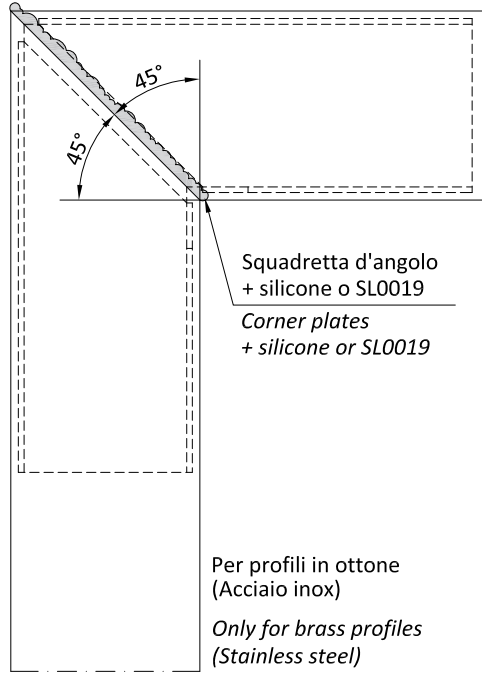
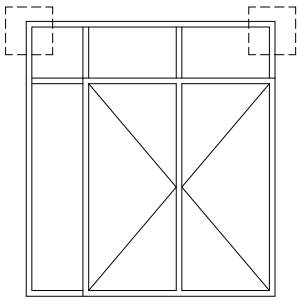

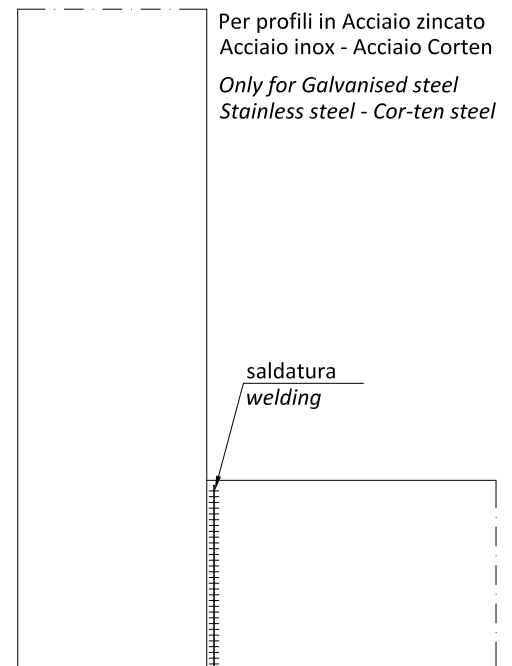
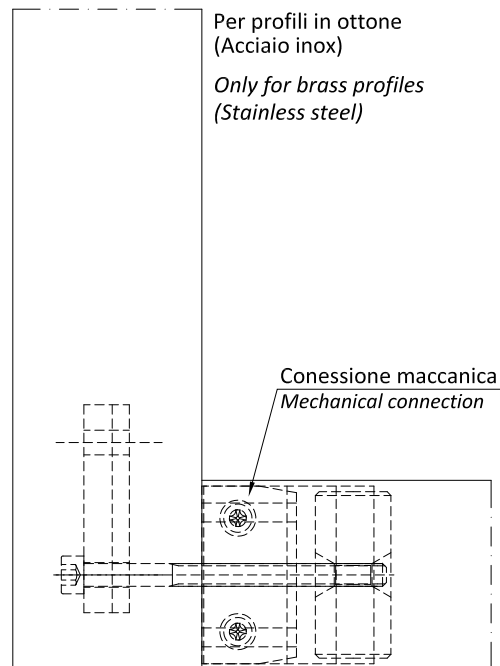
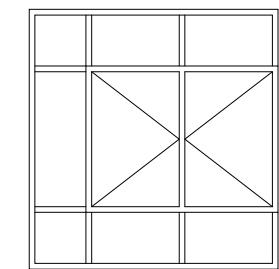
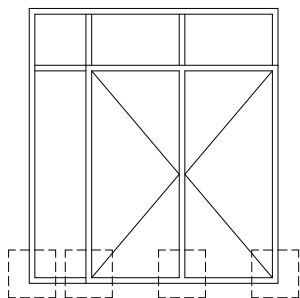
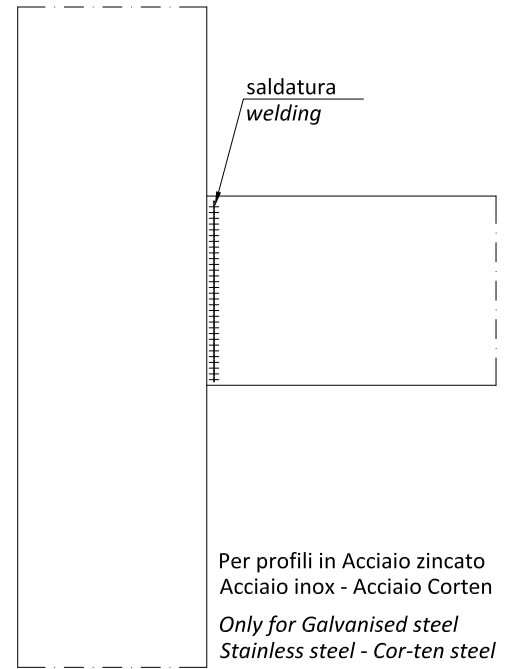
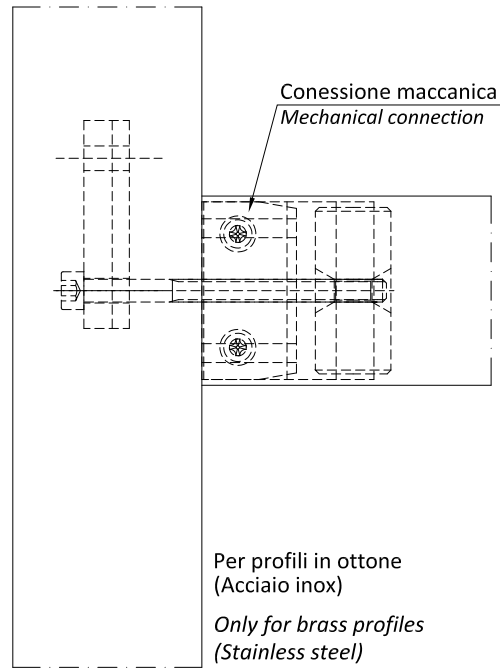
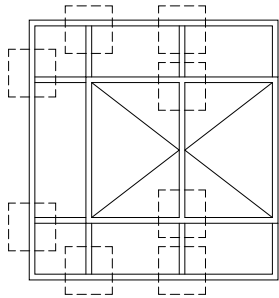
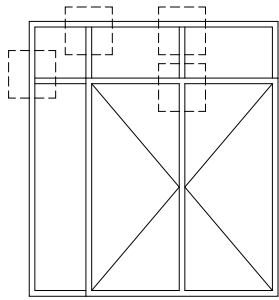

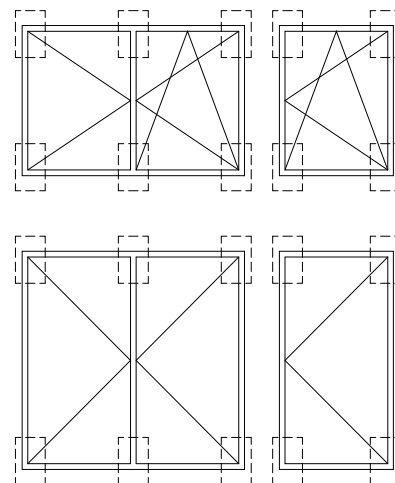
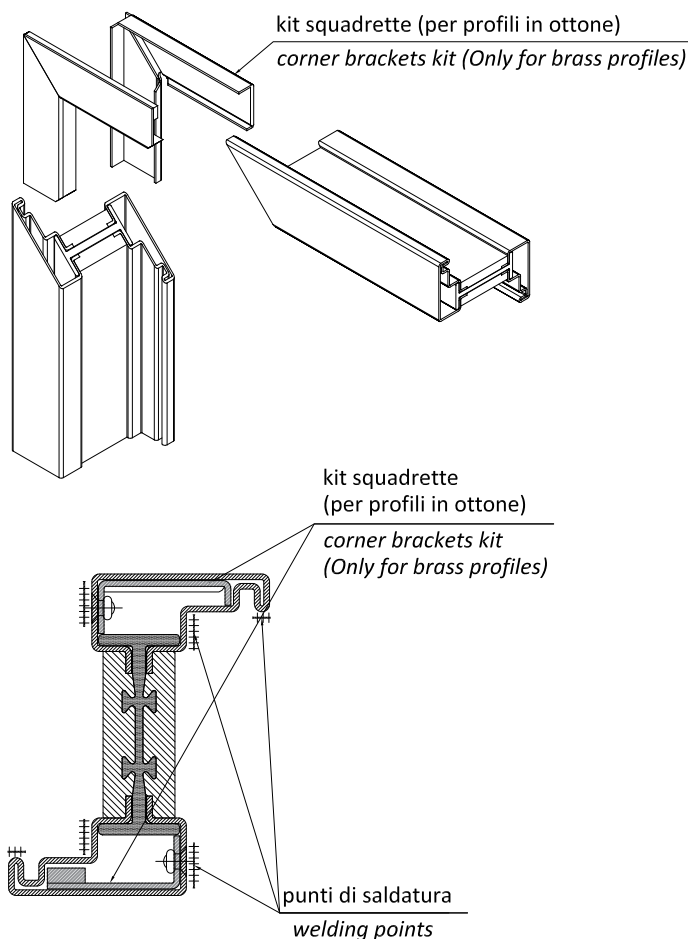

Ottone

Utilizzare le squadrette di allineamento, sigillare tutte le superfici di contatto tra i profili che non vanno saldate. Saldare a TIG a punti le zone indicate.

Brass

Use corner brackets, seal all surfaces in touch with profiles that are not to be seam-welded. Spot weld (TIG) the marked areas.

Acciaio zincato - Acciaio Corten - Acciaio inox

Saldare in continuo le superfici di contatto.

Galvanised steel - Cor-ten steel - Stainless steel

Seam-weld all contact surfaces.

Profilo	Profile	Kit squadrette	Corner brackets set
Codice	Code	Codice	Code
PR1101-PR1101		AC 1001I	
PR1102-PR1102		AC 1002I	
PR1103-PR1103		AC 1003I	
PR1111-PR1111		AC 1004I	
PR1112-PR1112		AC 1005I	
PR1113-PR1113		AC 1006I	telaio / frame
PR1113-PR1113		AC 1007I	anta / leaf
PR1112-PR1113		AC 1008I	
PR1105-PR1105		AC 1009I	
PR1110-PR1110		AC 1013I	
PR1127-PR1112		AC 1024ID	
PR1127-PR1112		AC 1024IS	

Profilo	Profile	Kit squadrette	Corner brackets set
Codice	Code	Codice	Code
PR1301-PR1301		AC 1201I	
PR1302-PR1302		AC 1202I	
PR1303-PR1303		AC 1203I	
PR1333-PR1333		AC 1207I	
PR1305-PR1305		AC 1209I	
PR1924-PR1333		AC 1208I	
PR1320-PR1320		AC 1730I	
PR1311-PR1311		AC 1731I	
PR1312-PR1312		AC 1732I	
PR1313-PR1313		AC 1733I	anta / leaf
PR1313-PR1313		AC 1733IE	telaio / frame
PR1315-PR1315		AC 1735I	

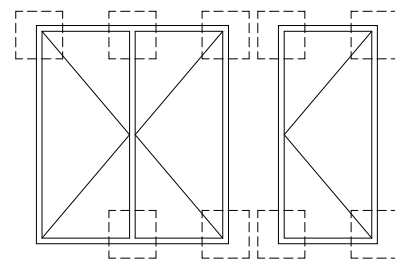
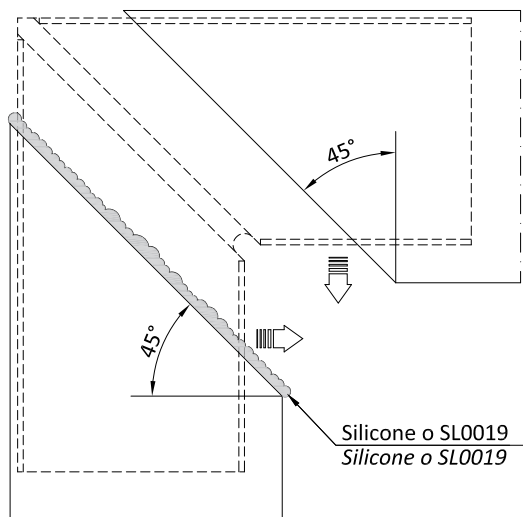

- 1) inserire la squadretta
- 2) siliconare nelle zone indicate
- 3) accostare i profili
- 4) procedere con la saldatura (vedasi pagine successive)

- 1) insert the bracket
- 2) seal in the specified areas
- 3) align the profiles
- 4) weld (see following pages)

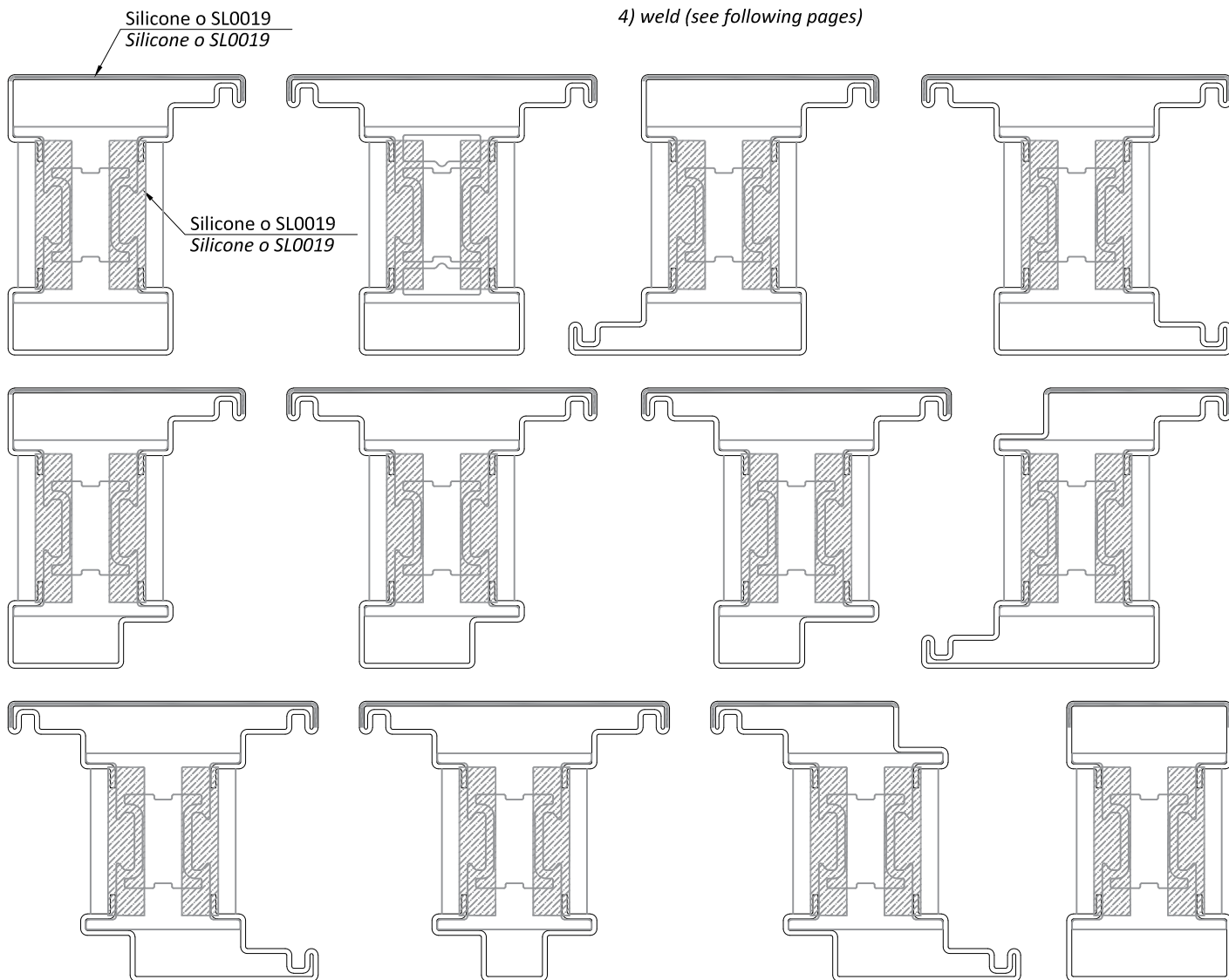

Sigillare con silicone o sigillante a freddo SL0019 nelle zone evidenziate (sempre lato esterno profilo)
 Seal with silicone or cold-working sealant SL0019 in the areas marked (always on the outer side of the profile)

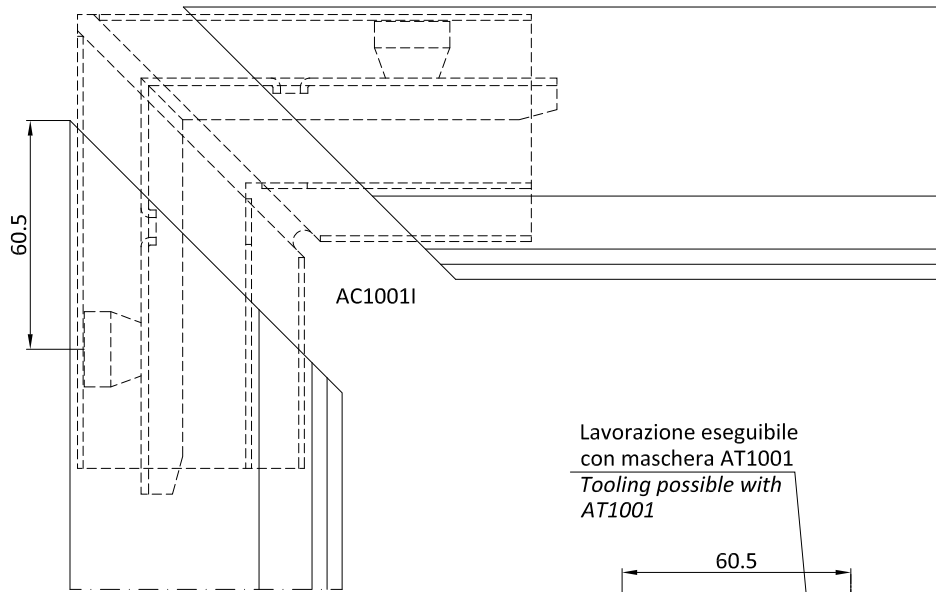

AC1001I

Lavorazione eseguibile
con maschera AT1001
Tooling possible with
AT1001

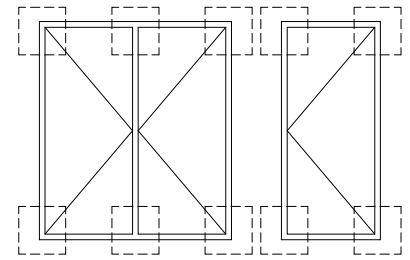
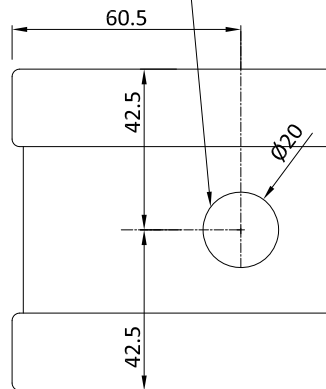
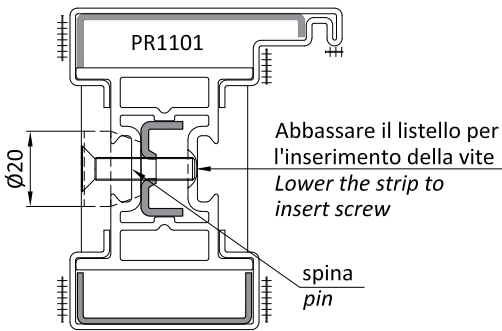

Saldare a TIG con materiale di riporto nelle zone indicate con #####

Sigillare tutte le superfici di contatto esterne con silicone o SL0019



TIG welding with filler material in the areas indicated with #####

Seal all the external contact surfaces with silicone our SL0019

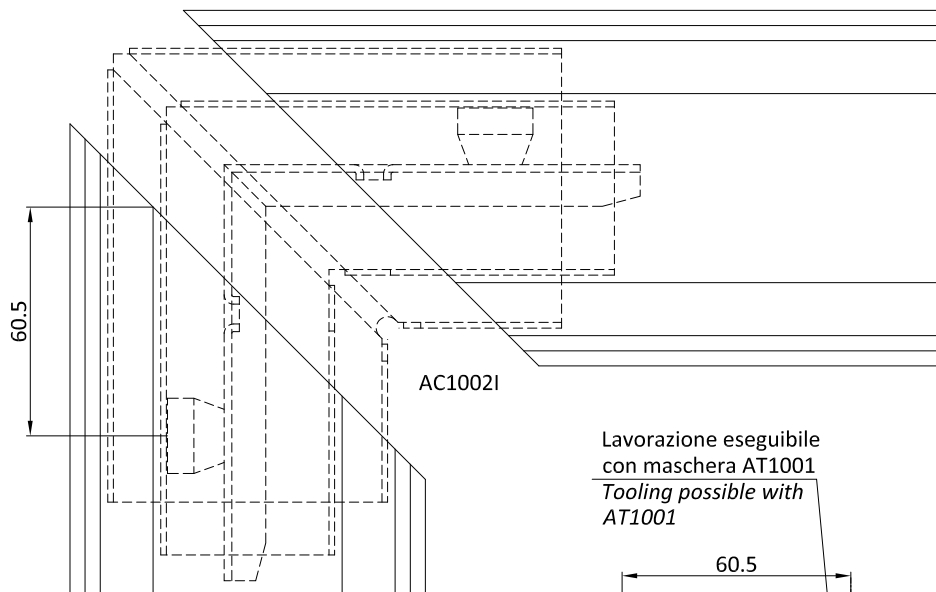

AC1002I

Lavorazione eseguibile
con maschera AT1001
Tooling possible with
AT1001

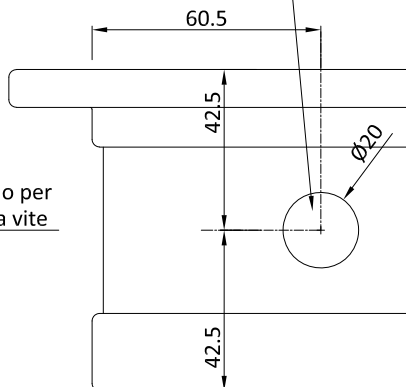
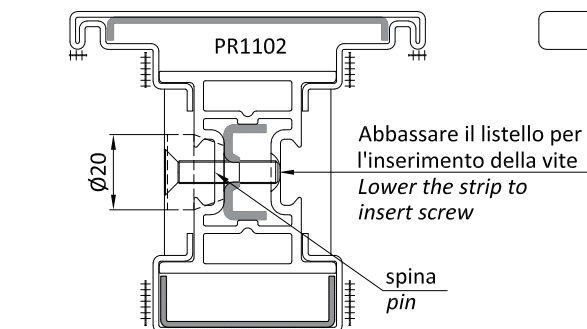

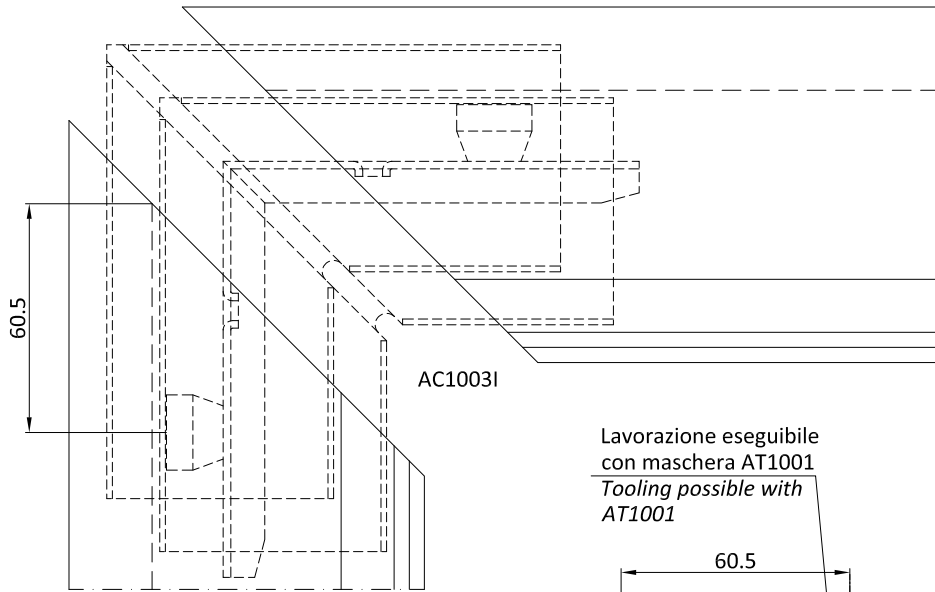

AC1003I

Lavorazione eseguibile
con maschera AT1001
*Tooling possible with
AT1001*

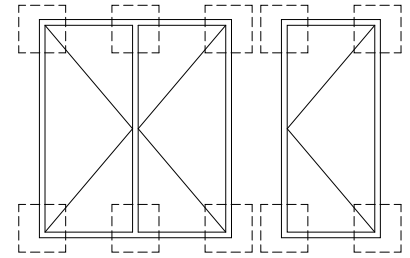
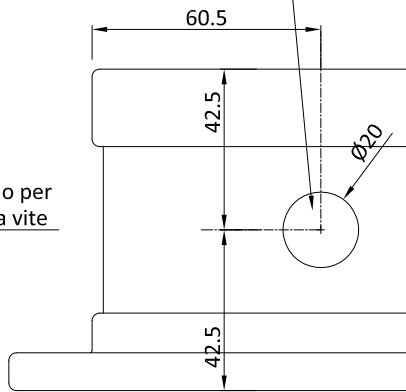
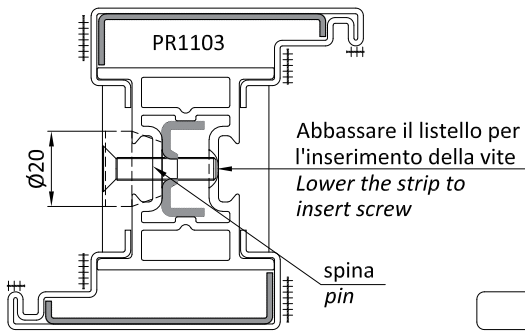

Saldare a TIG con materiale di riporto nelle zone indicate con #####

Sigillare tutte le superfici di contatto esterne con silicone o SL0019

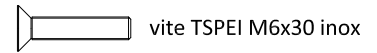

TIG welding with filler material in the areas indicated with #####

Seal all the external contact surfaces with silicone or SL0019

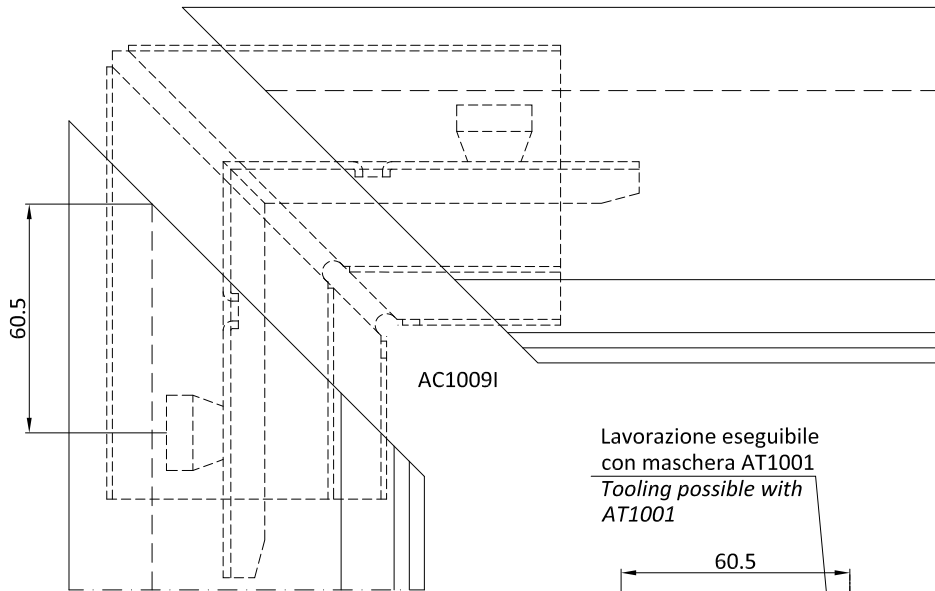

AC1009I

Lavorazione eseguibile
con maschera AT1001
*Tooling possible with
AT1001*

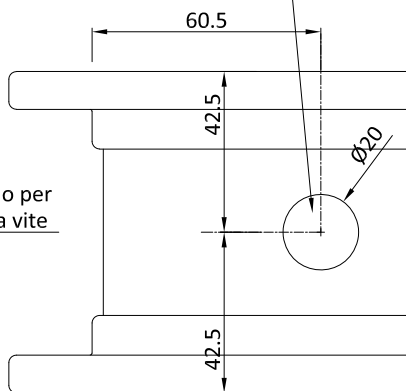
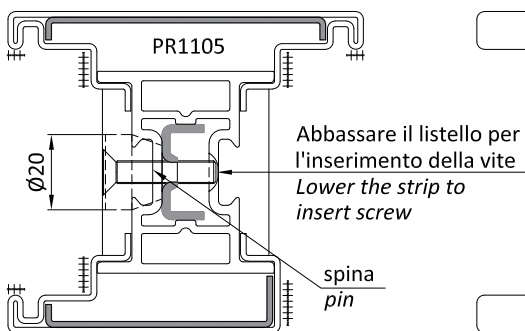

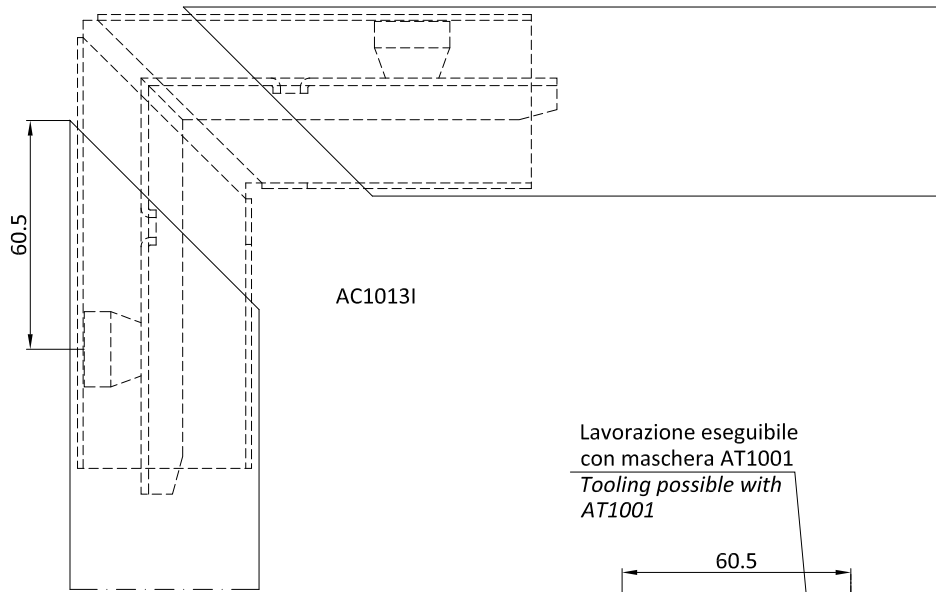

AC1013I

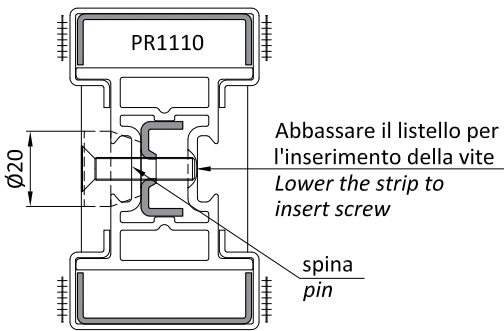

Lavorazione eseguibile con maschera AT1001
Tooling possible with AT1001

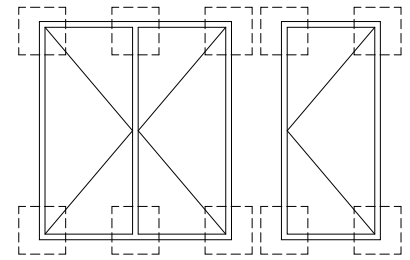
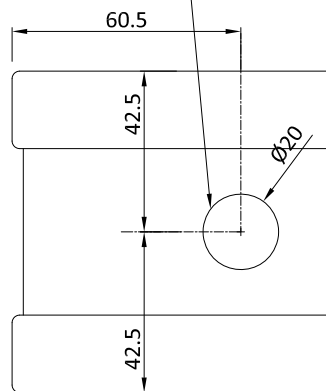

Saldare a TIG con materiale di riporto nelle zone indicate con #####

Sigillare tutte le superfici di contatto esterne con silicone o SL0019

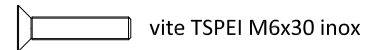

TIG welding with filler material in the areas indicated with #####

Seal all the external contact surfaces with silicone our SL0019

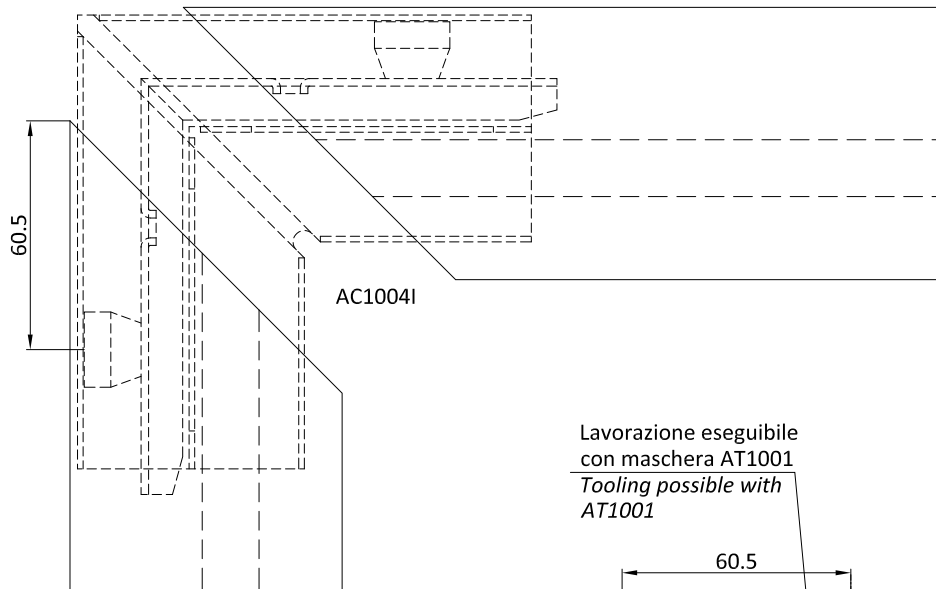

AC1004I

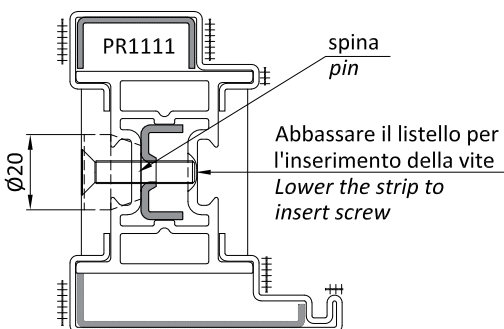

Lavorazione eseguibile con maschera AT1001
Tooling possible with AT1001

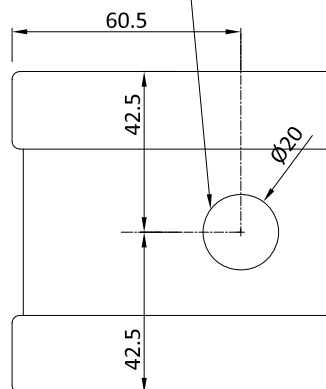

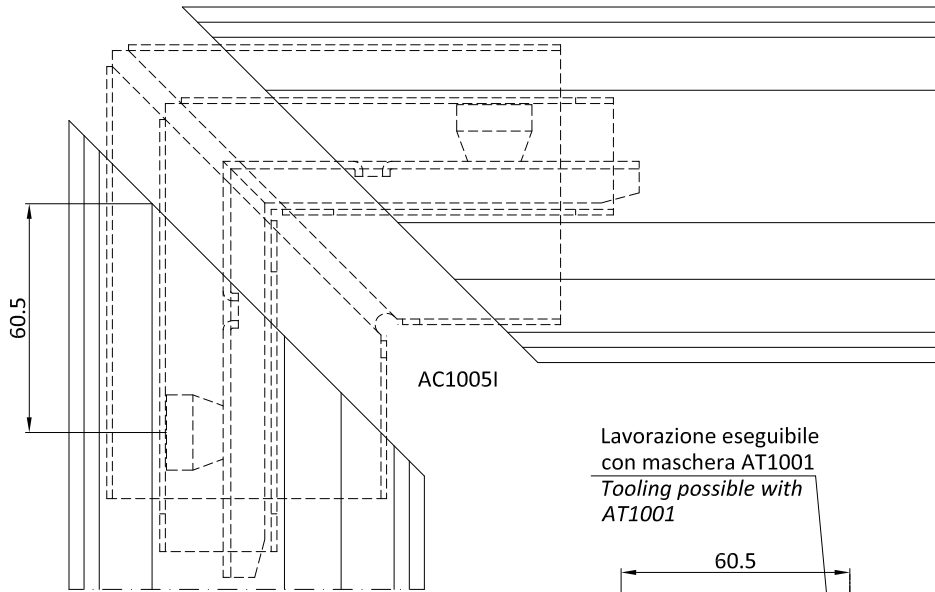

Lavorazione eseguibile
con maschera AT1001
Tooling possible with
AT1001

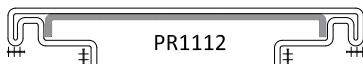
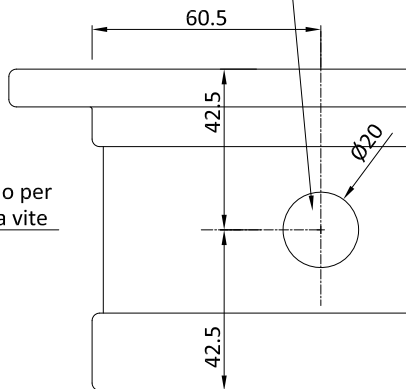

Ø20

Abbassare il listello per
l'inserimento della vite
Lower the strip to
insert screw

spina
pin

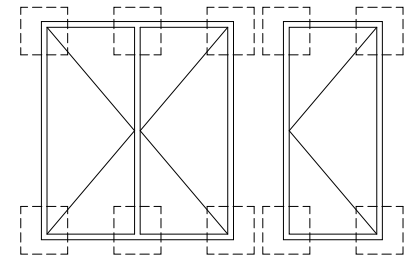

Saldare a TIG con materiale di riporto
nelle zone indicate con #####

Sigillare tutte le superfici di contatto
esterne con silicone o SL0019



TIG welding with filler material in the
areas indicated with #####

Seal all the external contact surfaces
with silicone our SL0019

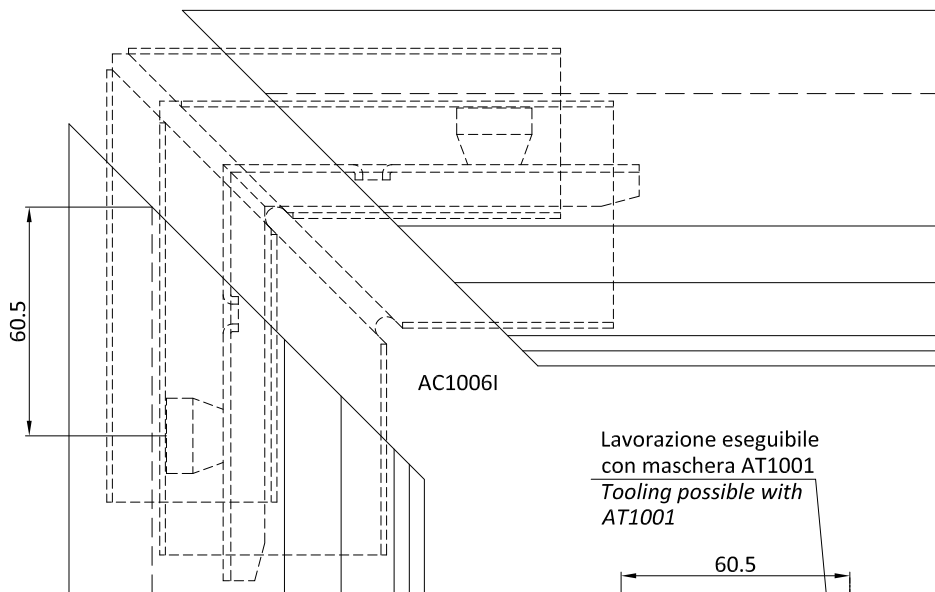

Lavorazione eseguibile
con maschera AT1001
Tooling possible with
AT1001

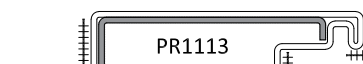
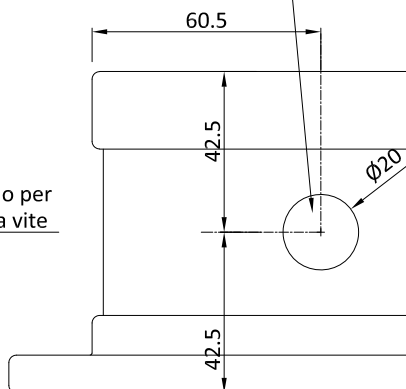

Ø20

Abbassare il listello per
l'inserimento della vite
Lower the strip to
insert screw

spina
pin

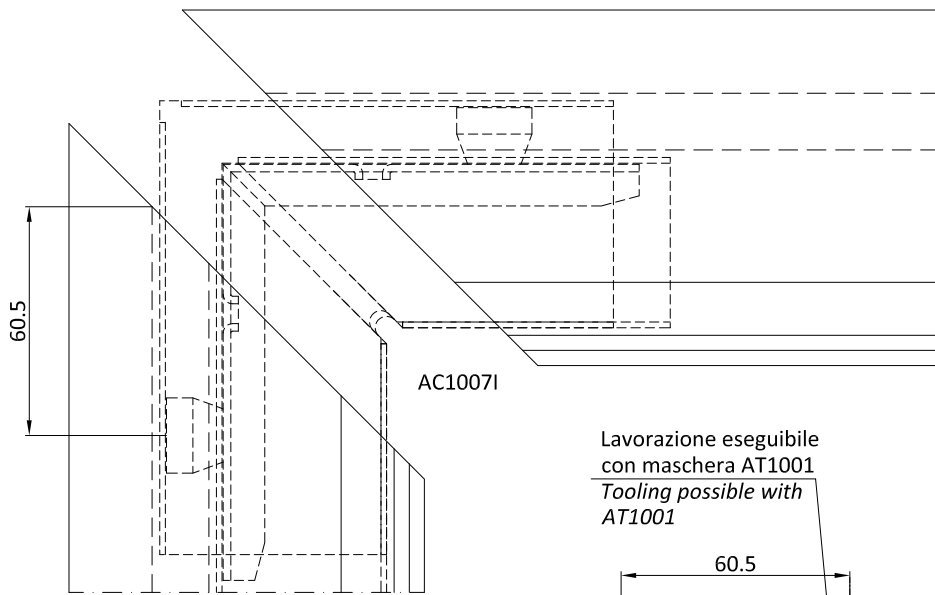

AC1007I

Lavorazione eseguibile
con maschera AT1001
*Tooling possible with
AT1001*

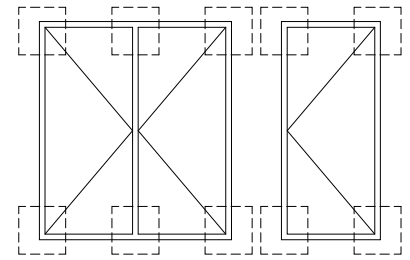
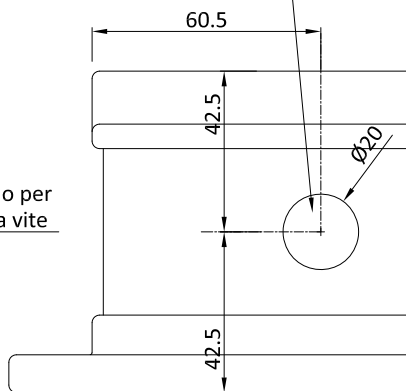
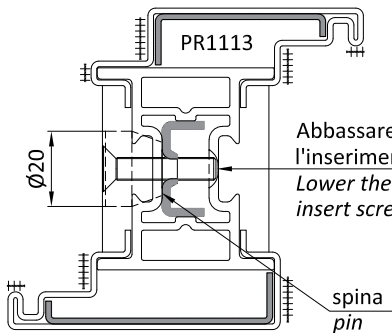

Saldare a TIG con materiale di riporto
nelle zone indicate con +++++

Sigillare tutte le superfici di contatto
esterne con silicone o SL0019



*TIG welding with filler material in the
areas indicated with +++++*

*Seal all the external contact surfaces
with silicone our SL0019*

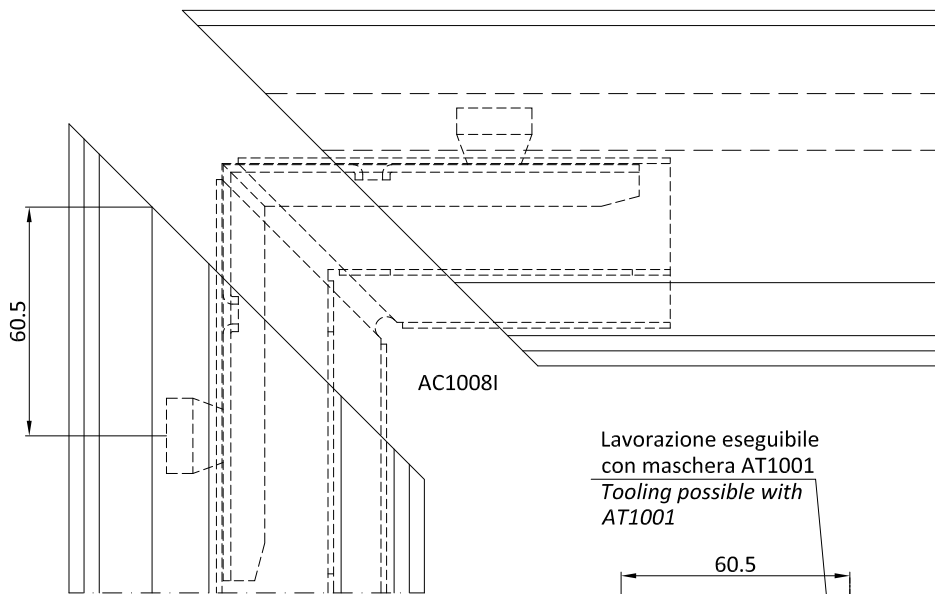

AC1008I

Lavorazione eseguibile
con maschera AT1001
*Tooling possible with
AT1001*

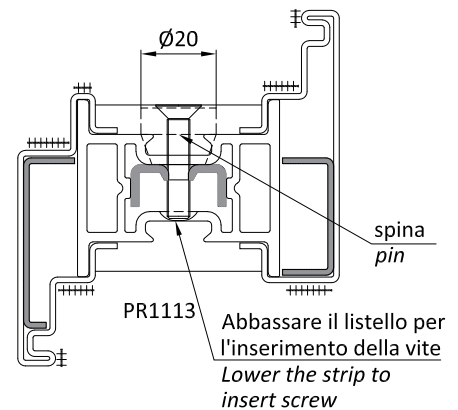
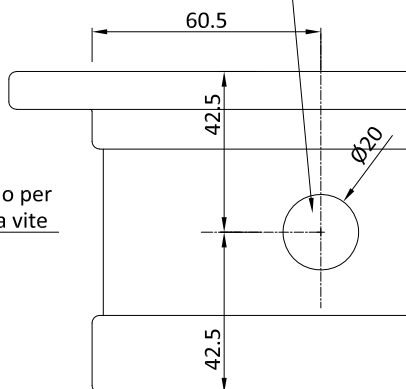
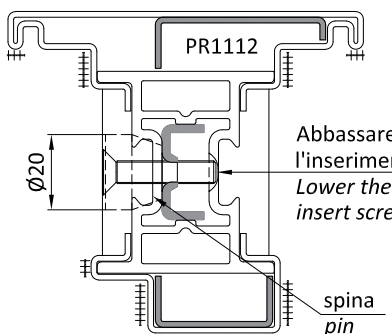

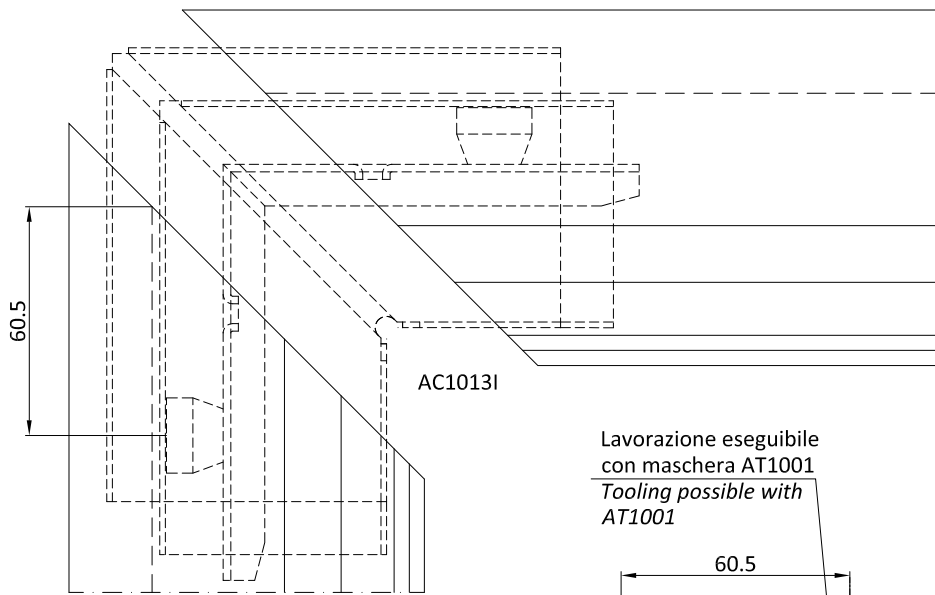

AC1013I

Lavorazione eseguibile
con maschera AT1001
Tooling possible with
AT1001

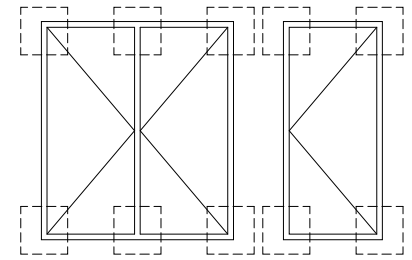

Saldare a TIG con materiale di riporto
nelle zone indicate con +++++

Sigillare tutte le superfici di contatto
esterne con silicone o SL0019



TIG welding with filler material in the
areas indicated with +++++

Seal all the external contact surfaces
with silicone our SL0019

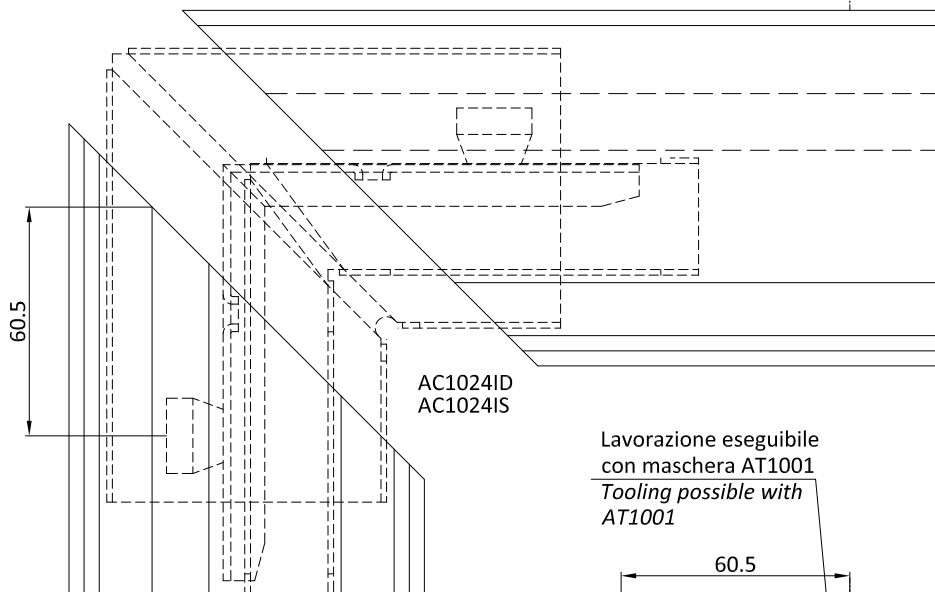
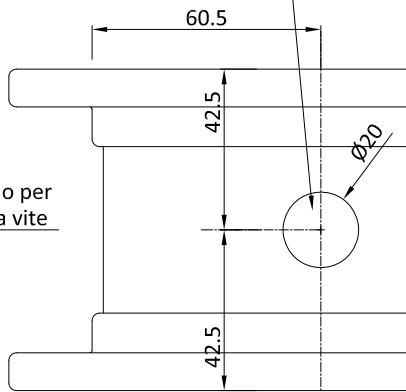
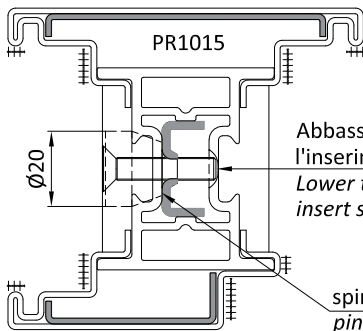

AC1024ID
AC1024IS

Lavorazione eseguibile
con maschera AT1001
Tooling possible with
AT1001

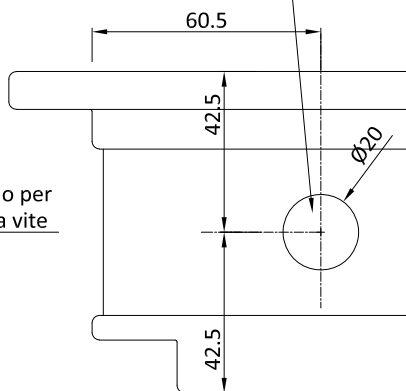
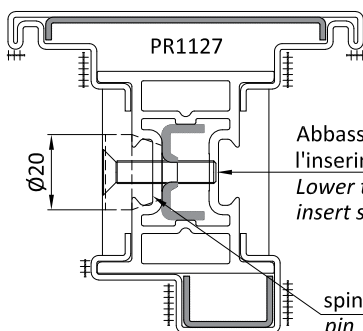
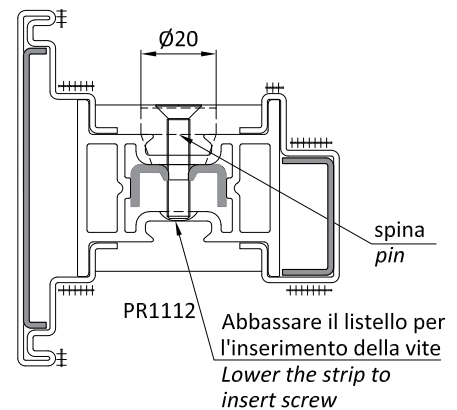

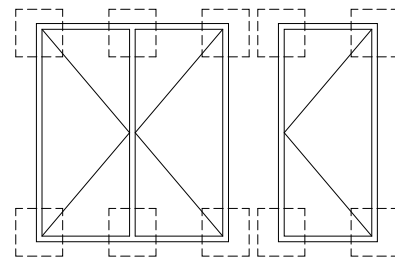
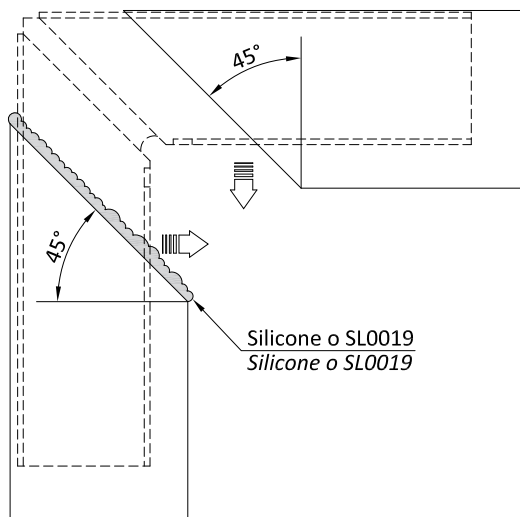

- 1) inserire la squadretta
- 2) siliconare nelle zone indicate
- 3) accostare i profili
- 4) procedere con la saldatura (vedasi pagine successive)

- 1) insert the bracket
- 2) seal in the specified areas
- 3) align the profiles
- 4) weld (see following pages)

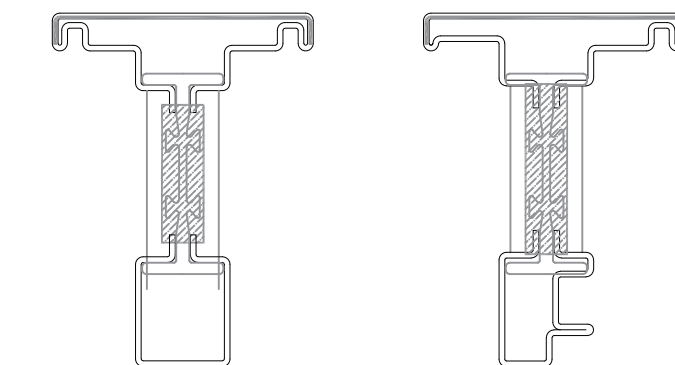
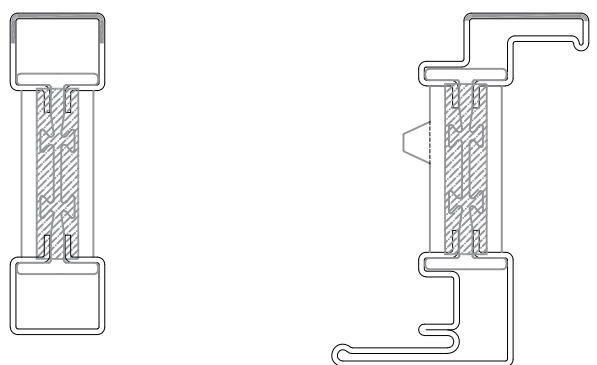
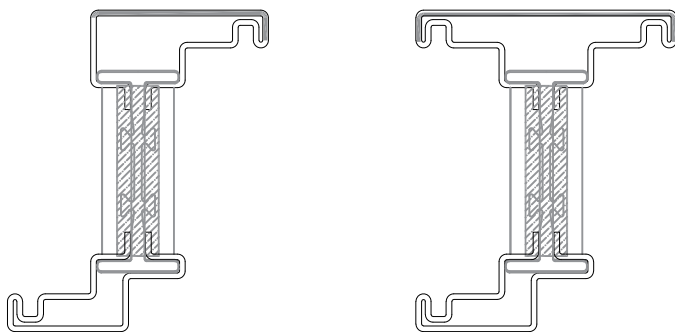
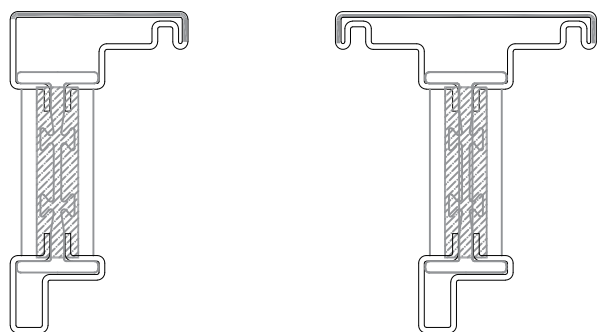
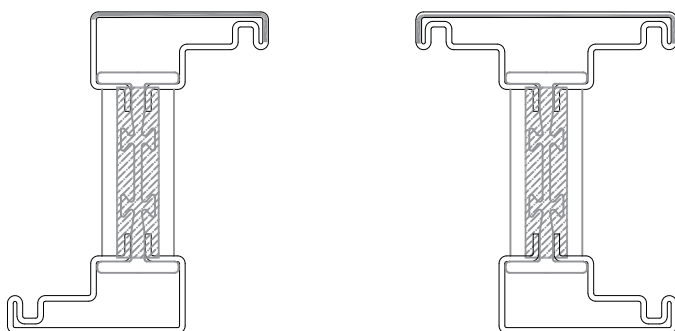
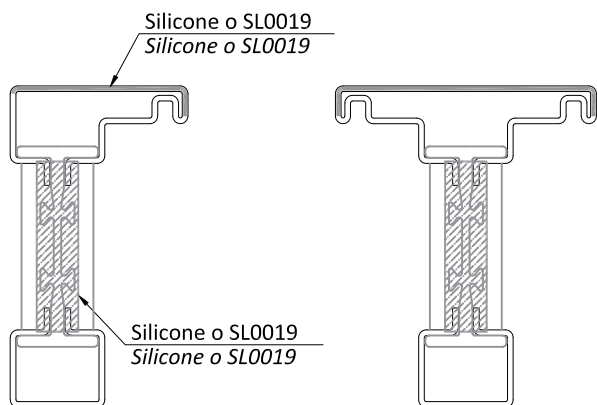

■ Sigillare con silicone o sigillante a freddo SL0019 nelle zone evidenziate (sempre lato esterno profilo)
 ■ Seal with silicone or cold-working sealant SL0019 in the areas marked (always on the outer side of the profile)

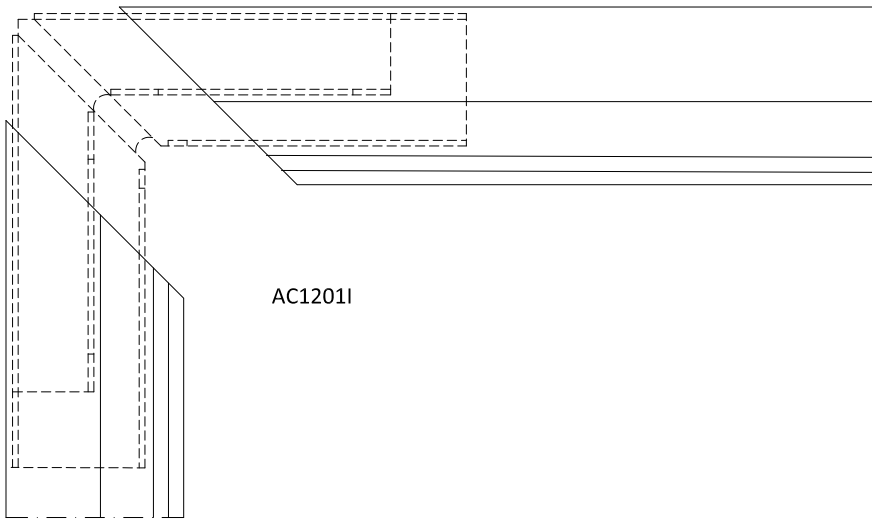

AC1201I

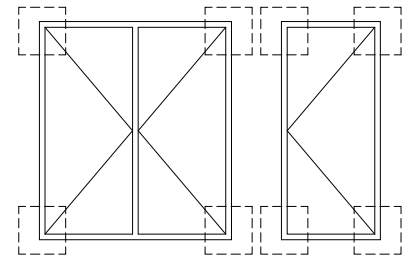

Saldare a TIG con materiale di riporto nelle zone indicate con +++++

Sigillare tutte le superfici di contatto esterne con silicone o SL0019

 Rivetti svasati Ø 4

TIG welding with filler material in the areas indicated with +++++

Seal all the external contact surfaces with silicone our SL0019

 Countersunk rivets Ø 4

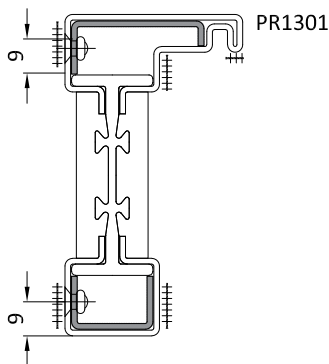

PR1301

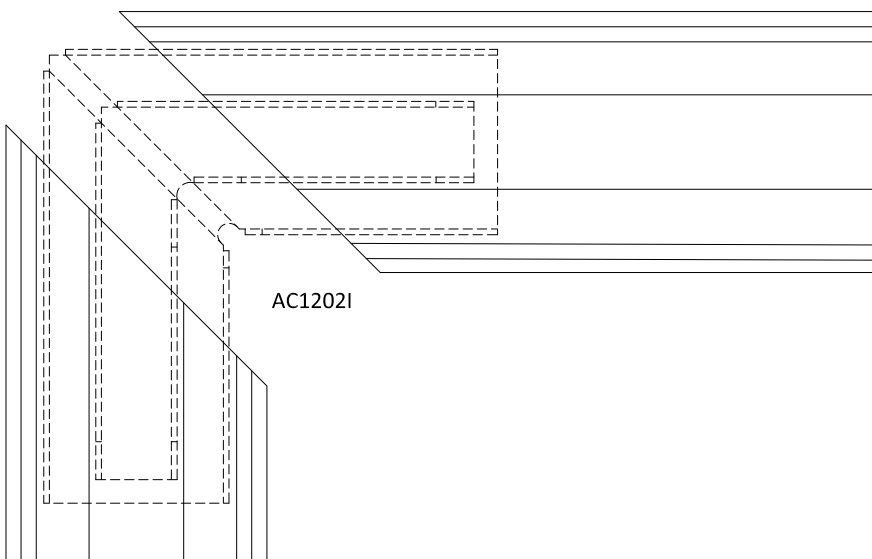

AC1202I

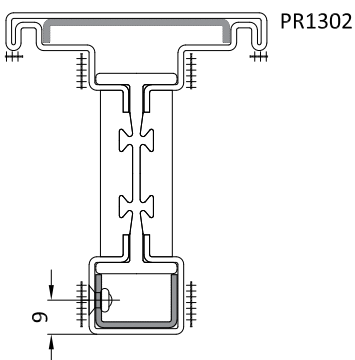

PR1302

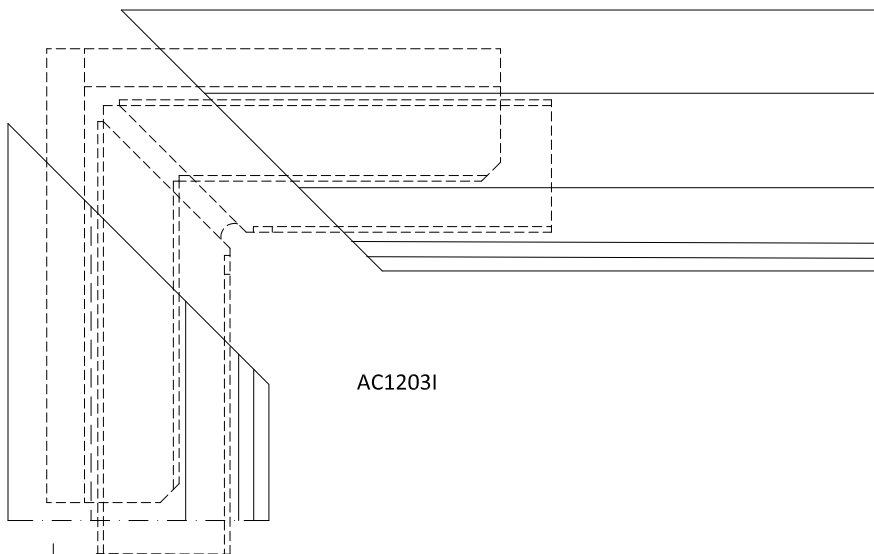

AC1203I

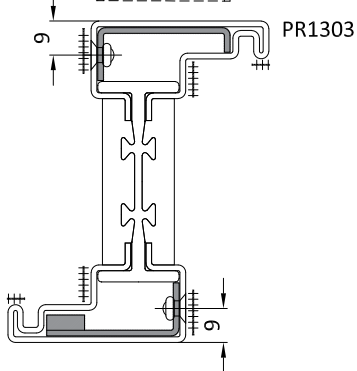

PR1303

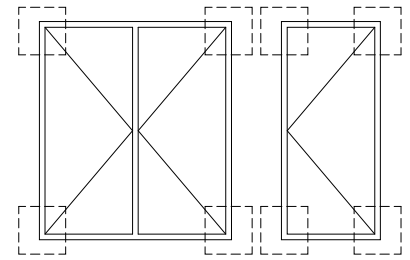

Saldare a TIG con materiale di riporto nelle zone indicate con +++++

Sigillare tutte le superfici di contatto esterne con silicone o SL0019

 Rivetti svasati Ø 4

TIG welding with filler material in the areas indicated with +++++

Seal all the external contact surfaces with silicone our SL0019

 Countersunk rivets Ø 4

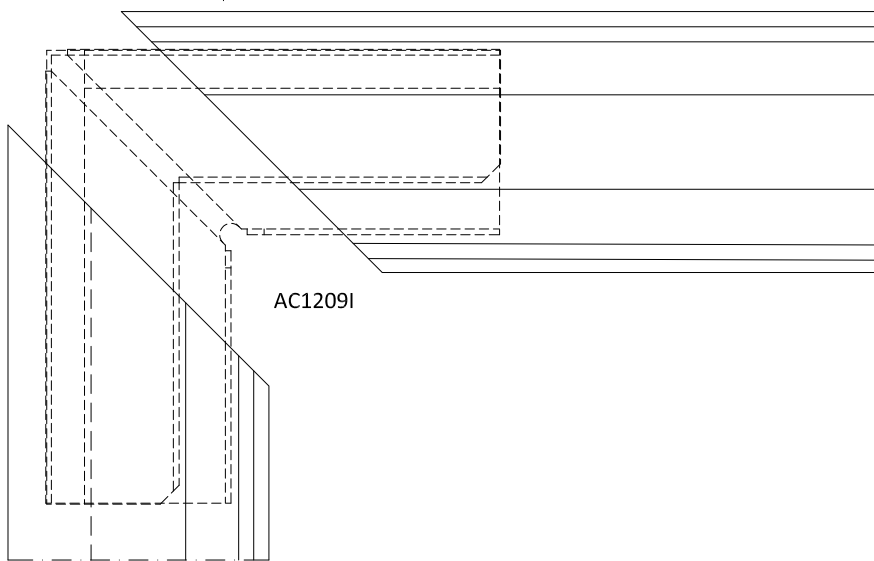

AC1209I

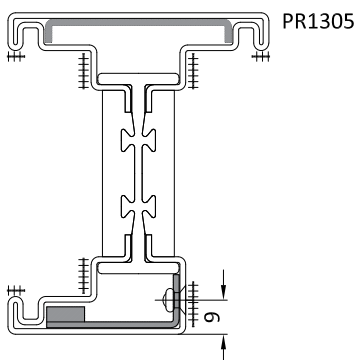

PR1305

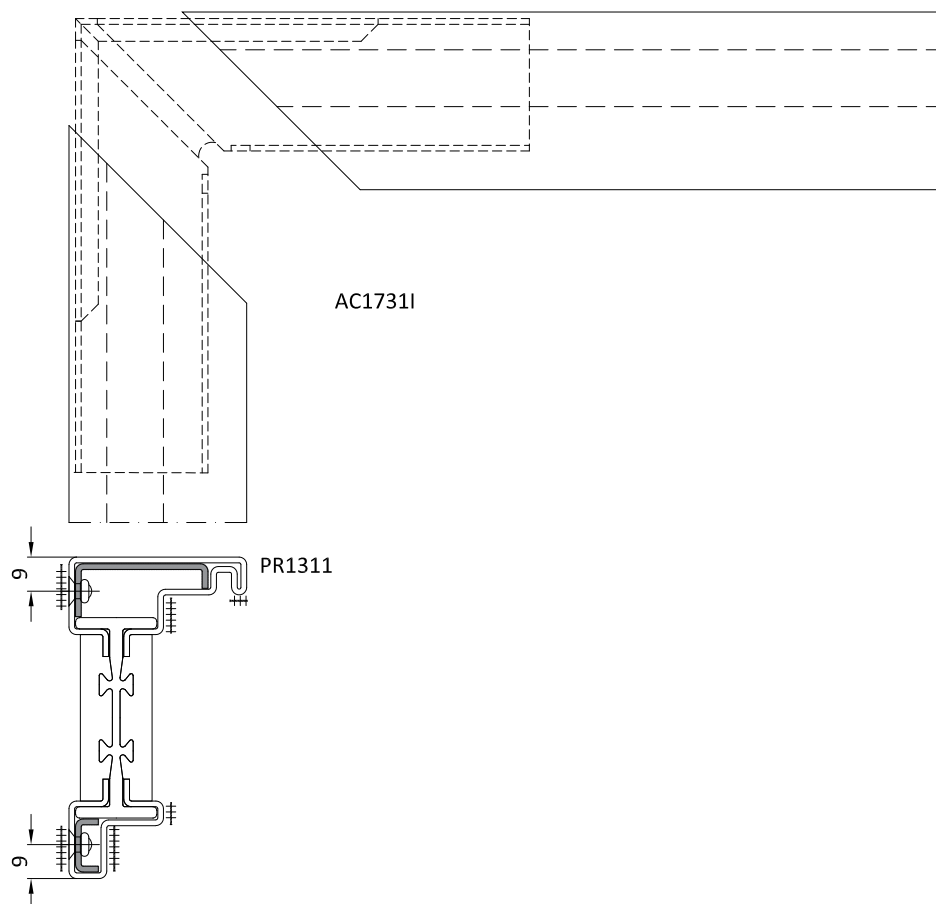

AC1731I

PR1311

PR1315

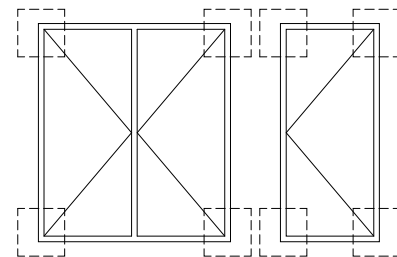

Saldare a TIG con materiale di riporto nelle zone indicate con #####

Sigillare tutte le superfici di contatto esterne con silicone o SL0019

 Rivetti svasati Ø 4

TIG welding with filler material in the areas indicated with #####

Seal all the external contact surfaces with silicone our SL0019

 Countersunk rivets Ø 4

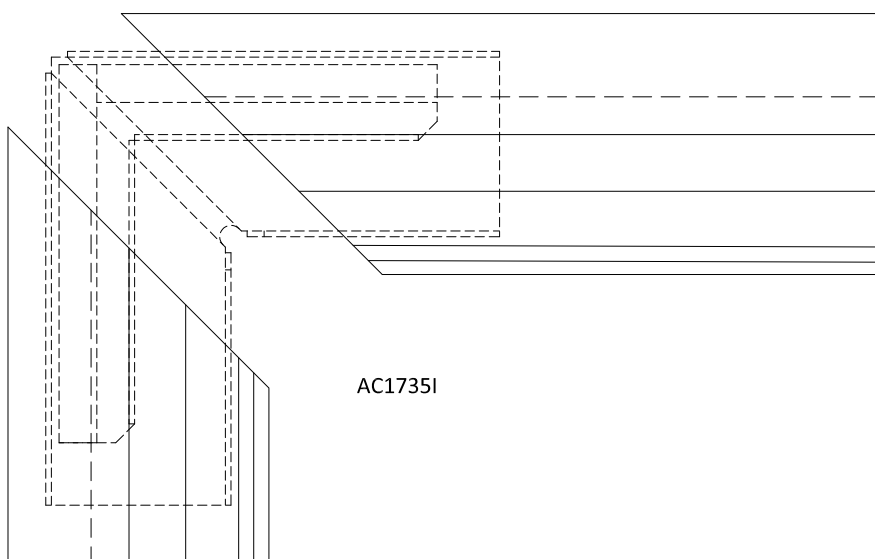

AC1735I

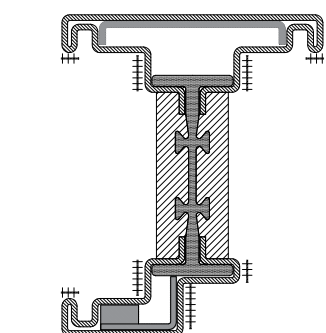

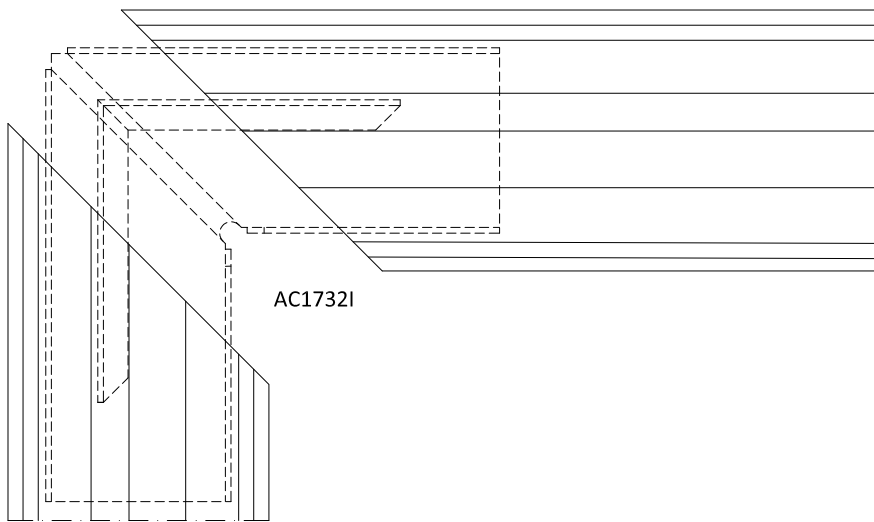

AC1732I

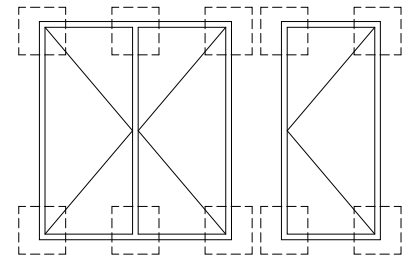

Saldare a TIG con materiale di riporto nelle zone indicate con +++++

Sigillare tutte le superfici di contatto esterne con silicone o SL0019

 Rivetti svasati Ø 4

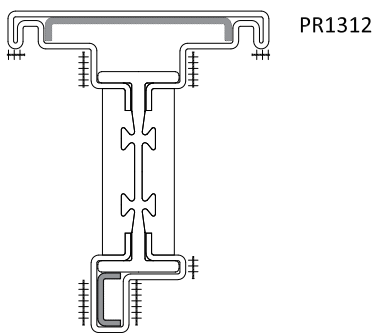

PR1312

TIG welding with filler material in the areas indicated with +++++

Seal all the external contact surfaces with silicone our SL0019

 Countersunk rivets Ø 4

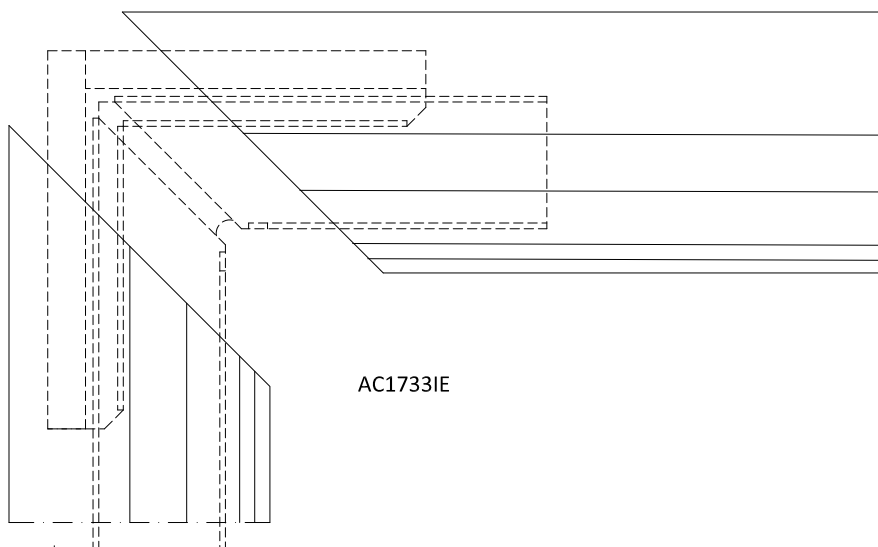

AC1733IE

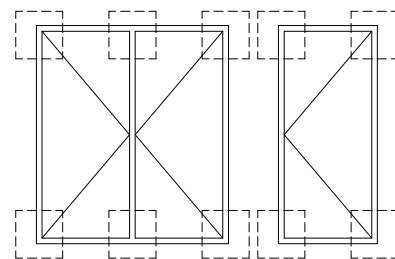

Saldare a TIG con materiale di riporto nelle zone indicate con #####

Sigillare tutte le superfici di contatto esterne con silicone o SL0019

 Rivetti svasati Ø 4

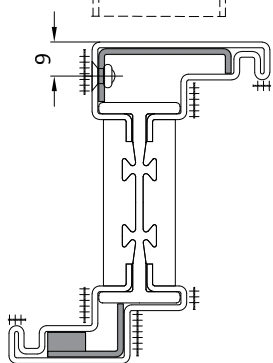

PR1313 (telaio | frame)

TIG welding with filler material in the areas indicated with #####

Seal all the external contact surfaces with silicone our SL0019

 Countersunk rivets Ø 4

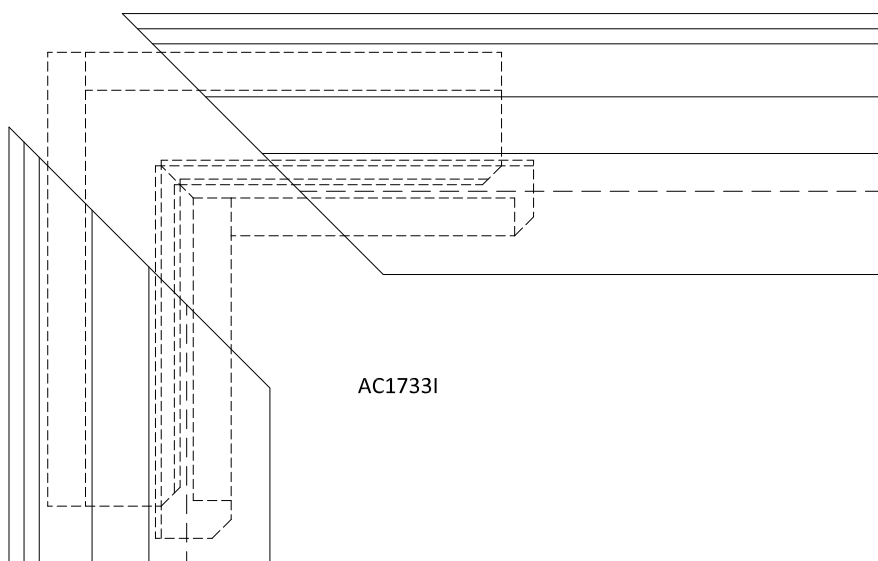

AC1733I

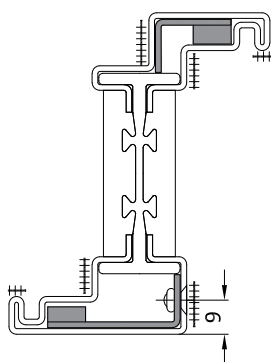

PR1313 (anta | leaf)

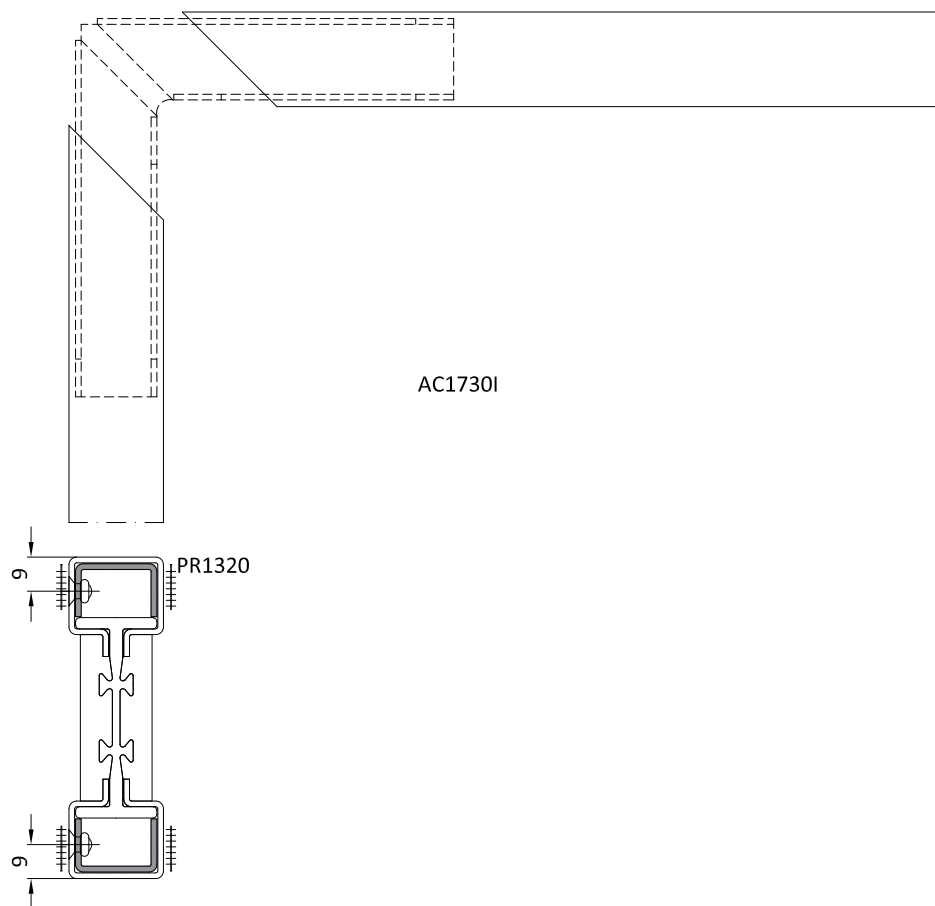

AC1730I

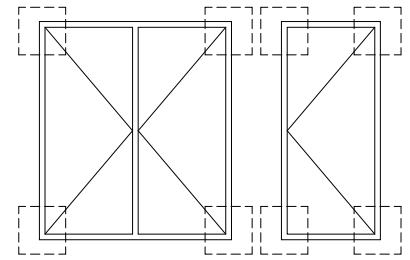

Saldare a TIG con materiale di riporto nelle zone indicate con #####

Sigillare tutte le superfici di contatto esterne con silicone o SL0019

 Rivetti svasati $\varnothing 4$

TIG welding with filler material in the areas indicated with #####

Seal all the external contact surfaces with silicone our SL0019

 Countersunk rivets $\varnothing 4$

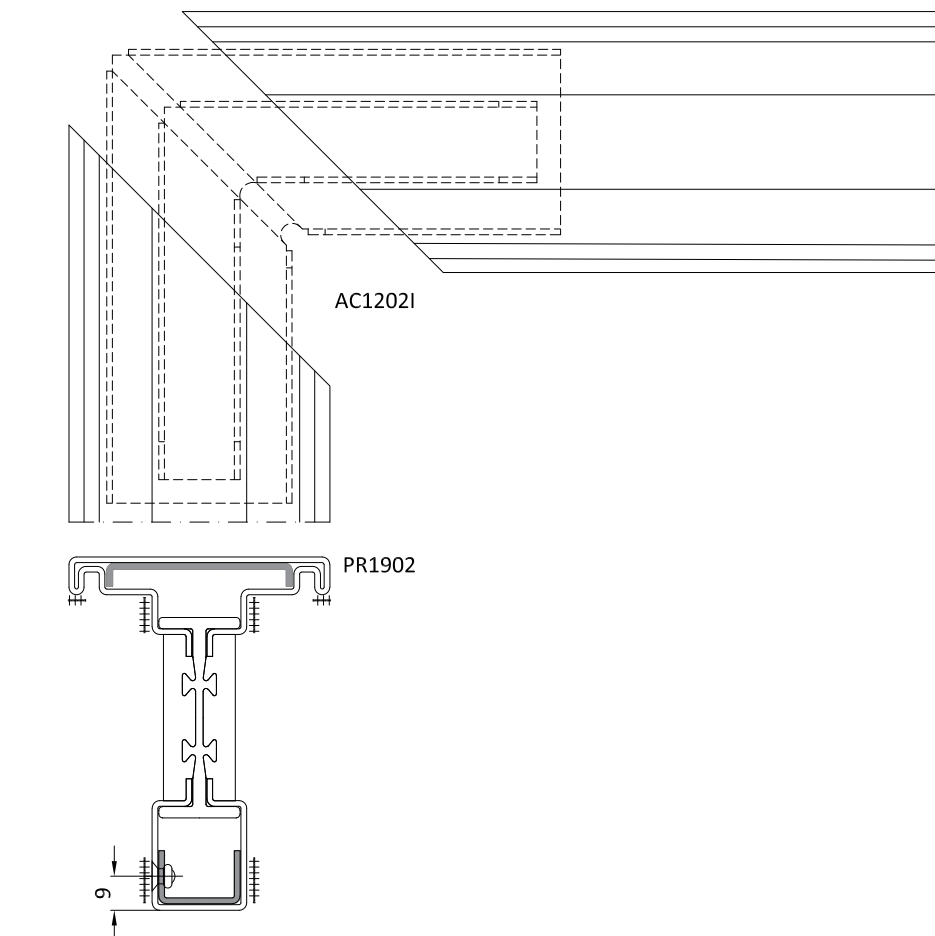

AC1202I

PR1902

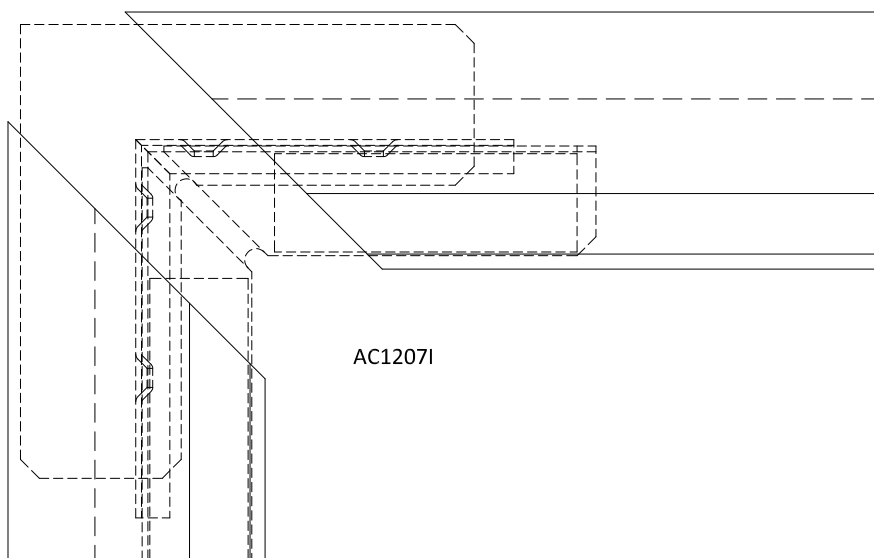

AC12071

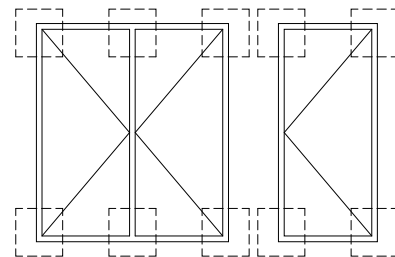

Saldare a TIG con materiale di riporto nelle zone indicate con +++++

Sigillare tutte le superfici di contatto esterne con silicone o SL0019

 Rivetti svasati $\varnothing 4$

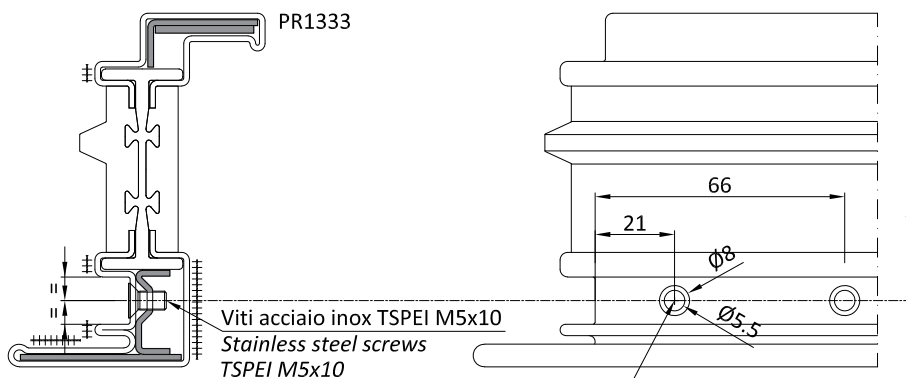

PR1333

Viti acciaio inox TSPEI M5x10
Stainless steel screws
TSPEI M5x10

TIG welding with filler material in the areas indicated with +++++

Seal all the external contact surfaces with silicone our SL0019

 Countersunk rivets $\varnothing 4$

Fori imbutiti per Viti TSPEI M5x10 con stampo AT1233
Deep-drawn holes for TSPEI M5x10 screws with
mould AT1233

Saldare a TIG con materiale di riporto nelle zone indicate con 

TIG welding with filler material in the areas indicated with 

Sigillare tutte le superfici di contatto esterne con silicone o SL0019

Seal all the external contact surfaces with silicone our SL0019

 Rivetti svasati $\varnothing 4$

 Countersunk rivets $\varnothing 4$

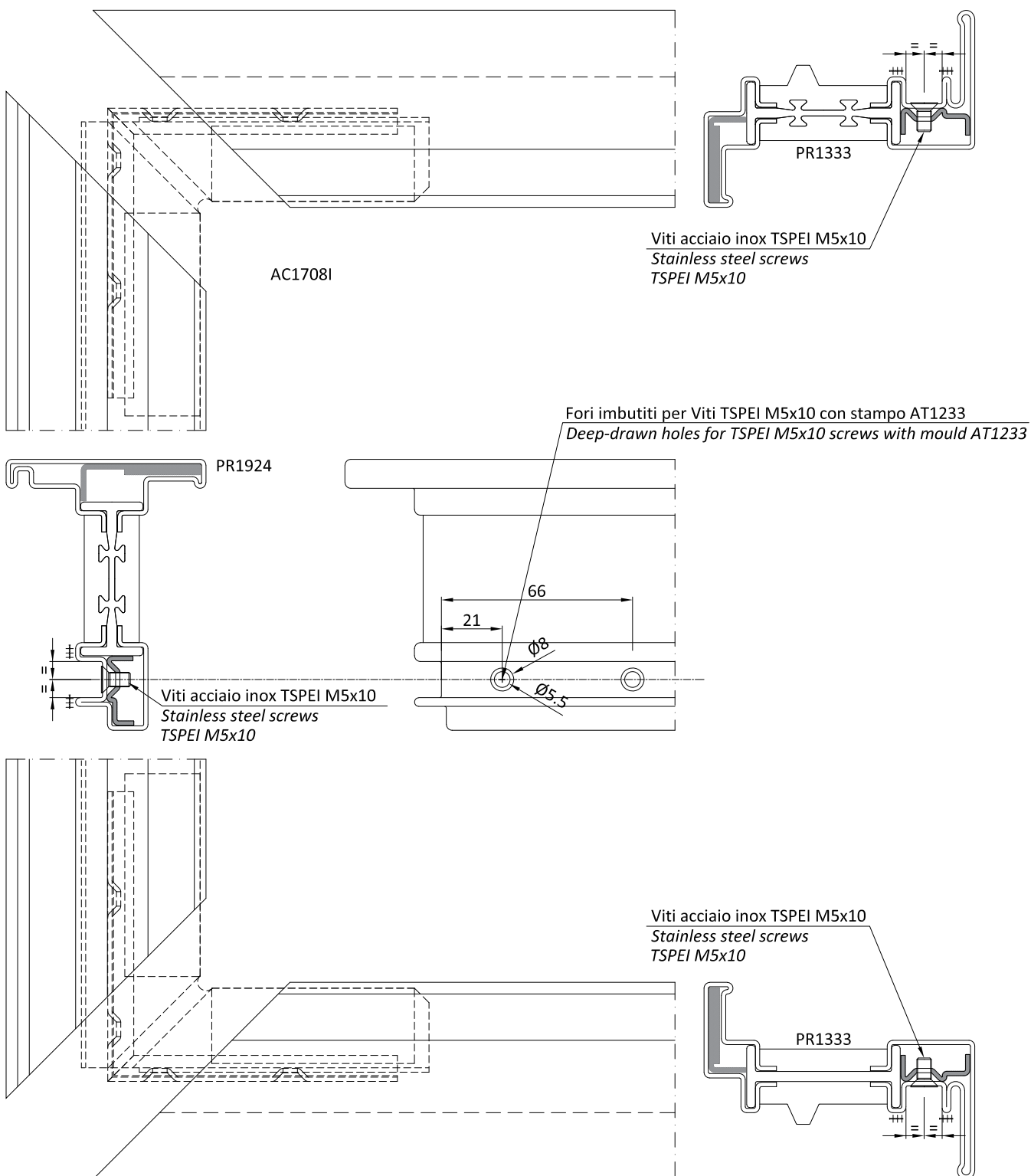
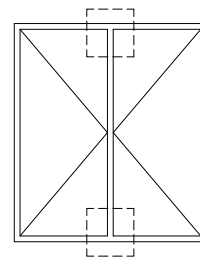

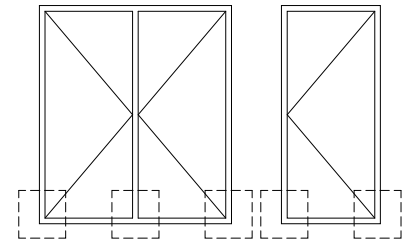
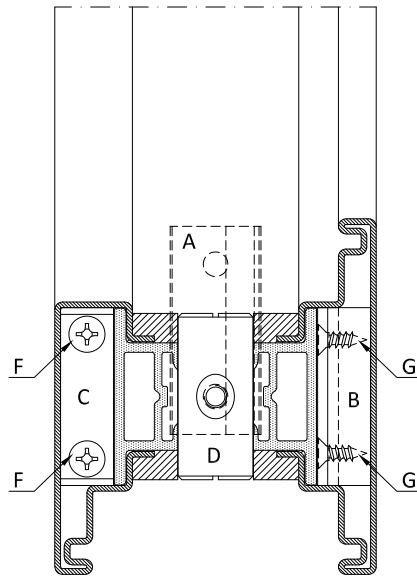
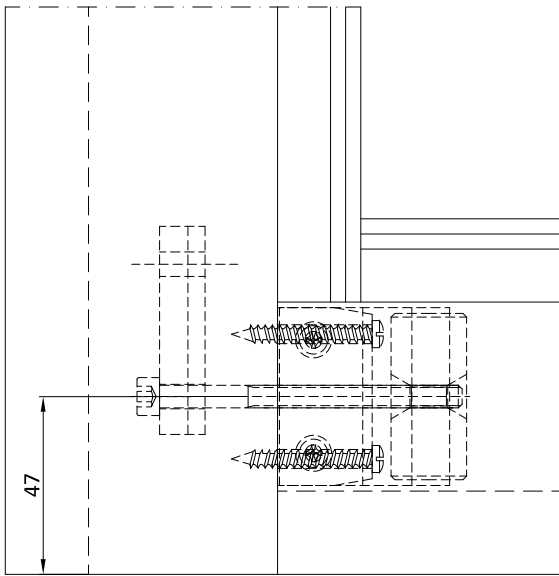

Saldare a TIG con materiale di riporto nelle zone indicate con

Sigillare tutte le superfici di contatto con silicone o SL0019

- A) Inserto di fissaggio
- B) Cavallotto di allineamento lato esterno
- C) Cavallotto di allineamento lato interno
- D) Tirante per cavallotto
- E) Vite acciaio inox TCEI M6x80
- F) Vite acciaio inox TC 4.8x38
- G) Vite autofilettante TSTC 3.9x9.5

TIG welding with filler material in the areas indicated with

Seal all the external contact surfaces with silicone or SL0019

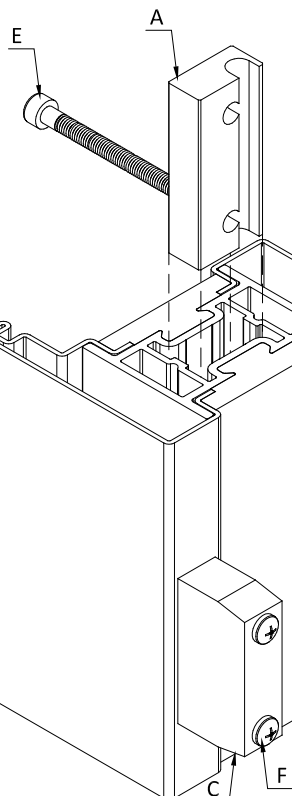
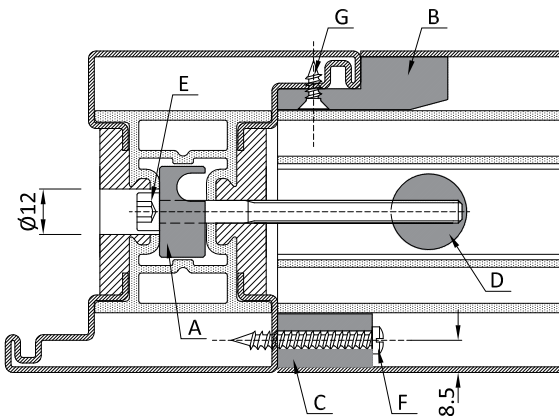

- A) Anchoring insert
- B) U-bolt for alignment outer side
- C) U-bolt for alignment inner side
- D) Adapter sleeve for U-bolt
- E) Stainless steel screws TCEI M6x80
- F) Stainless steel screws TC 4.8x38
- G) Self-threading screws TSTC 3.9x9.5

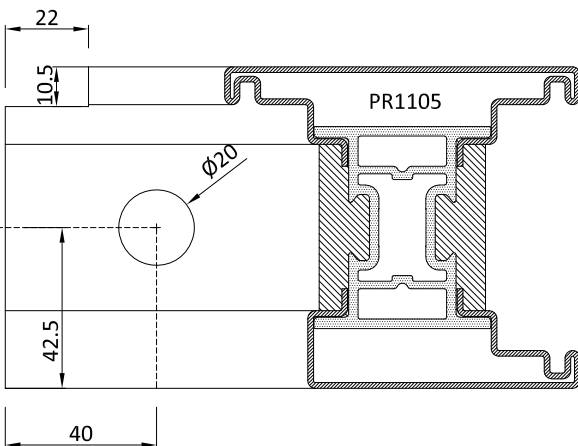
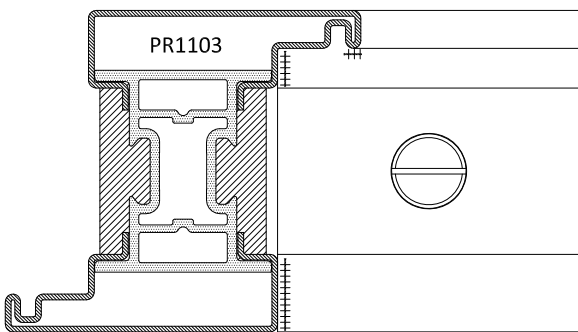

Lavorazione valida per profili PR1101 - PR1102 - 1105
Tooling valid for profiles PR1101 - PR1102 - PR1105

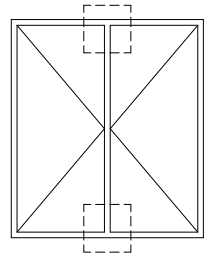
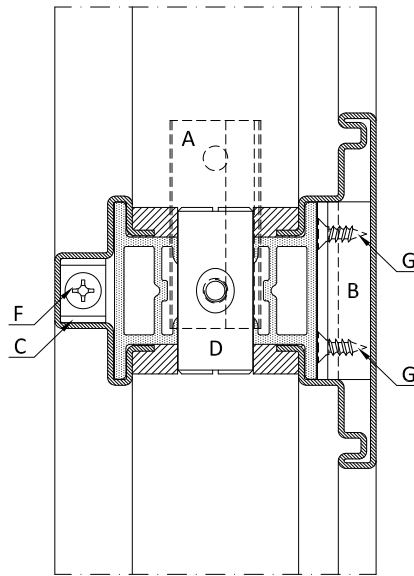
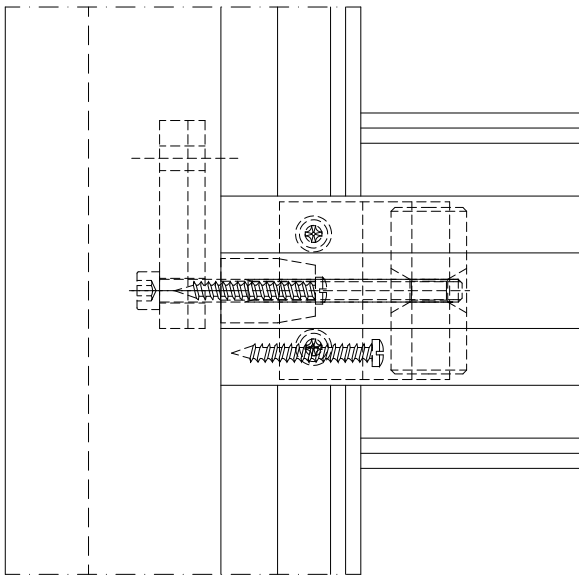

Saldare a TIG con materiale di riporto nelle zone indicate con

Sigillare tutte le superfici di contatto con silicone o SL0019

- A) Inserto di fissaggio
- B) Cavallotto di allineamento lato esterno
- C) Cavallotto di allineamento lato interno
- D) Tirante per cavallotto
- E) Vite acciaio inox TCEI M6x80
- F) Vite acciaio inox TC 4.8x38
- G) Vite autofilettante TSTC 3.9x9.5

TIG welding with filler material in the areas indicated with

Seal all the external contact surfaces with silicone or SL0019

- A) Anchoring insert
- B) U-bolt for alignment outer side
- C) U-bolt for alignment inner side
- D) Adapter sleeve for U-bolt
- E) Stainless steel screws TCEI M6x80
- F) Stainless steel screws TC 4.8x38
- G) Self-threading screws TSTC 3.9x9.5

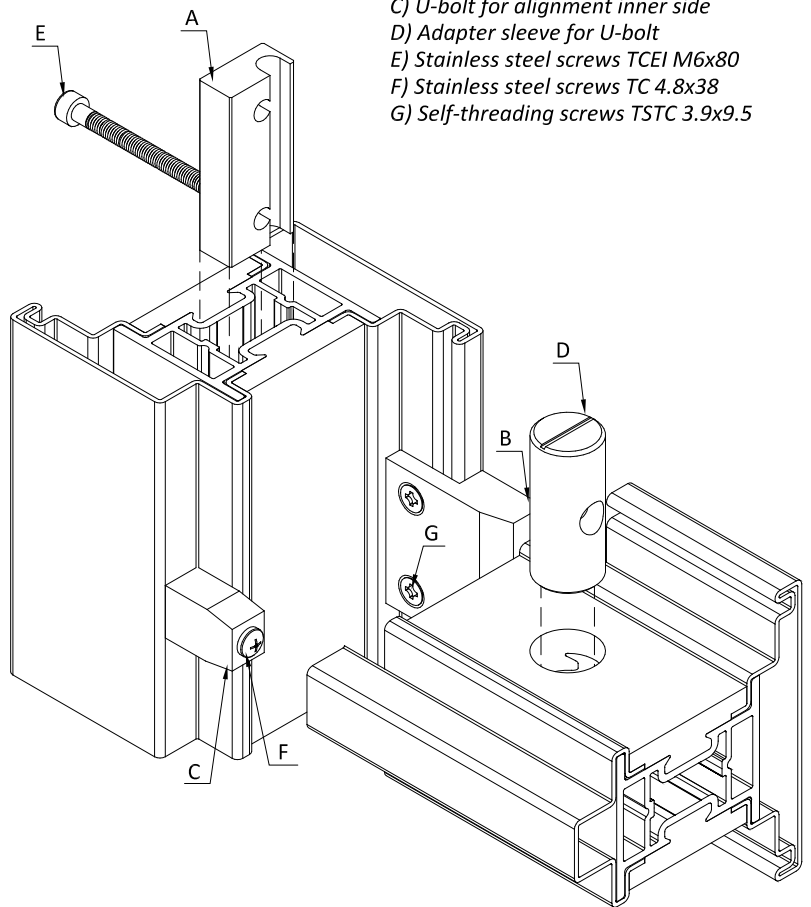
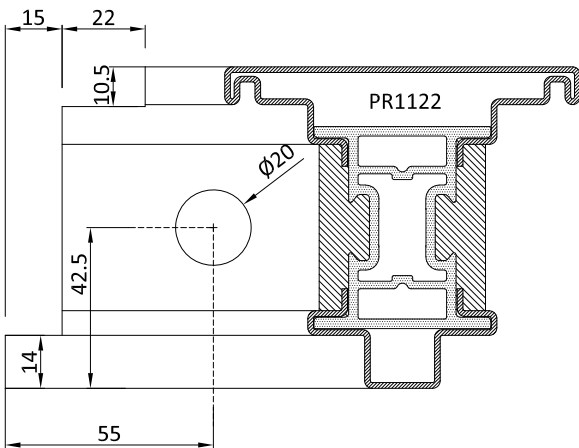
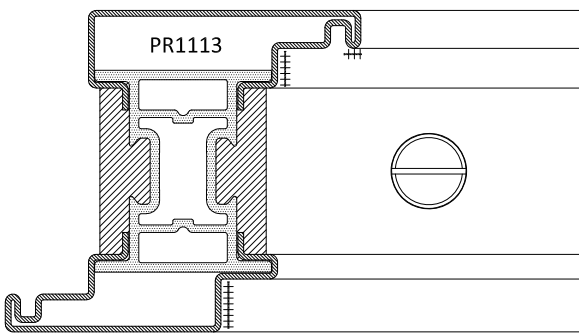
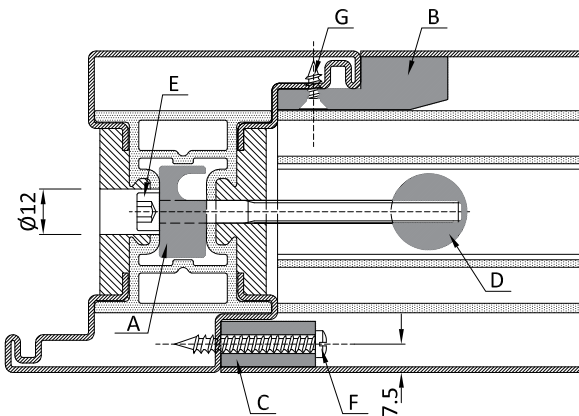

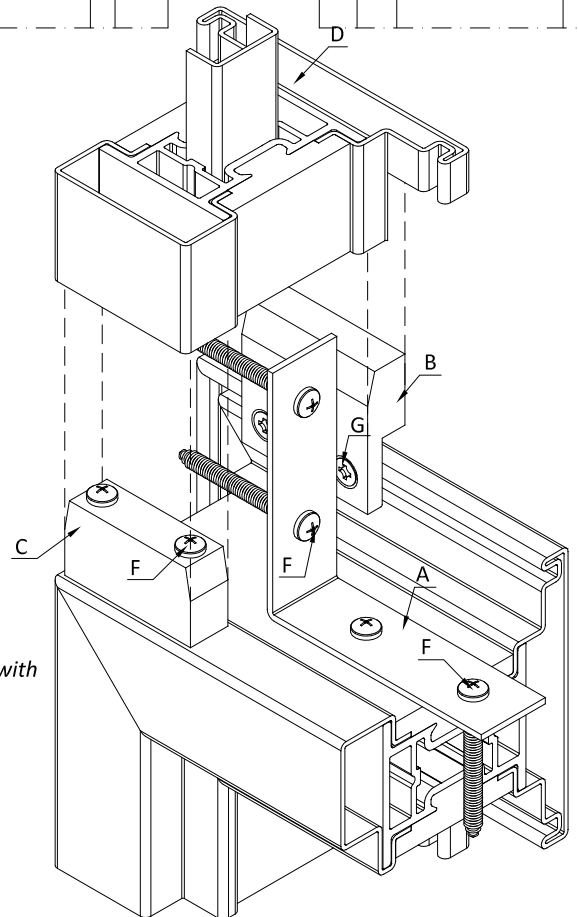
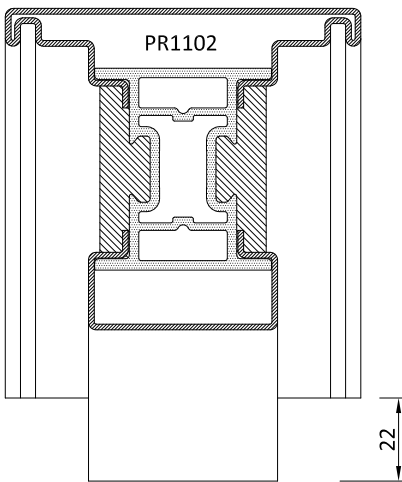
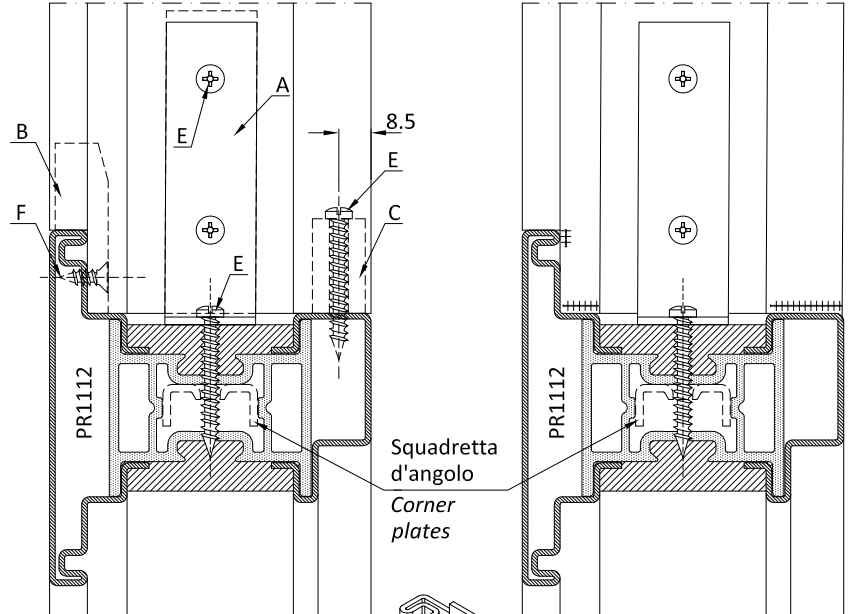
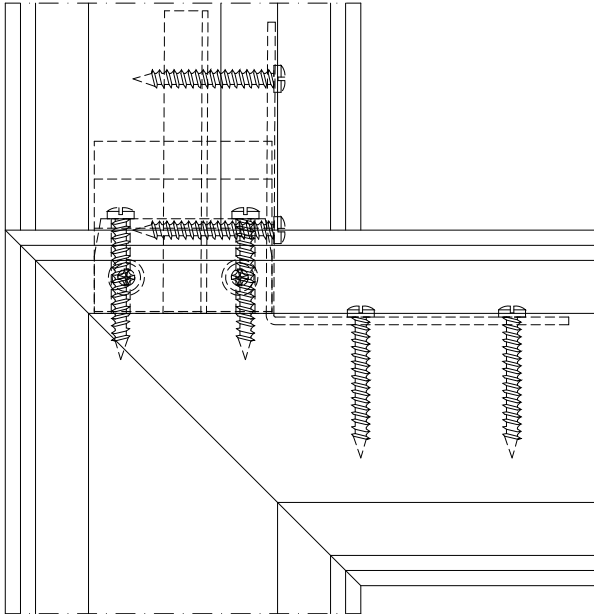
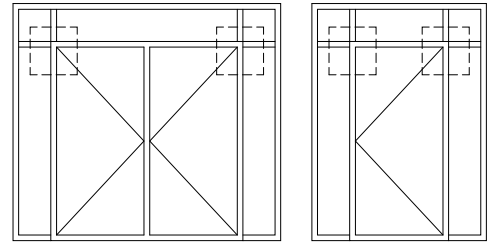
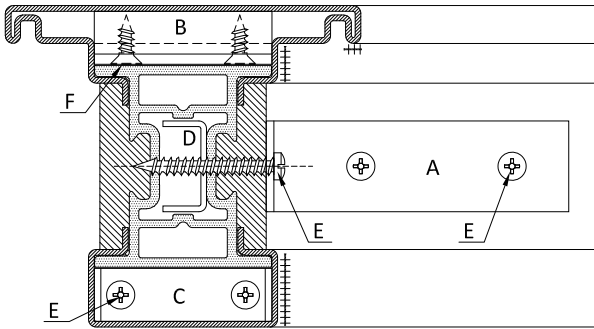

Saldare a TIG con materiale di riporto nelle zone indicate con +++++

TIG welding with filler material in the areas indicated with +++++

Sigillare tutte le superfici di contatto con silicone o SL0019

Seal all the external contact surfaces with silicone or SL0019

- A) Squadretta giunzione 90°
- B) Cavallotto di allineamento lato esterno
- C) Cavallotto di allineamento lato interno
- D) Rinforzo interno
- E) Vite acciaio inox TC 4.8x38
- F) Vite autofilettante TSTC 3.9x9.5

- A) Corner bracket 90°
- B) U-bolt for alignment outer side
- C) U-bolt for alignment inner side
- D) Internal reinforcement
- E) Stainless steel screws TC 4.8x38
- F) Self-threading screws TSTC 3.9x9.5

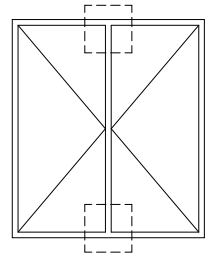
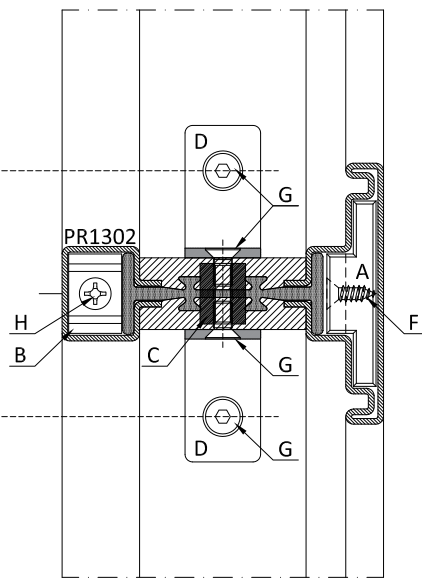
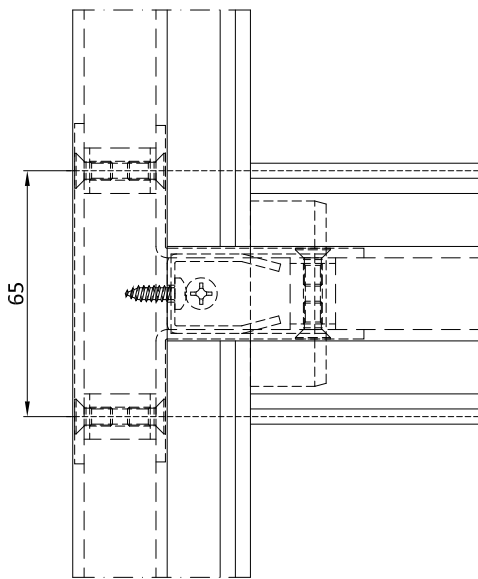

Saldare a TIG con materiale di riporto nelle zone indicate con +++++

Sigillare tutte le superfici di contatto con silicone o SL0019

- A) Cavallotto di allineamento lato interno
- B) Cavallotto di allineamento lato esterno
- C) Bussola filettata
- D) Squadretta di tiraggio
- E) Piastrina di fissaggio
- F) Vite acciaio inox TPS 4.2x13
- G) Vite acciaio inox TSPEI M5x10
- H) Vite autofilettante TC 4.2x13

TIG welding with filler material in the areas indicated with +++++

Seal all the external contact surfaces with silicone or SL0019

- A) U-bolt for alignment inner side
- B) U-bolt for alignment outer side
- C) Threaded bush
- D) Corner bracket
- E) Fixing plate
- F) Stainless steel screws TPS 4.2x13
- G) Stainless steel screws TSPEI M5x10
- H) Self-threading screws TC 4.2x13

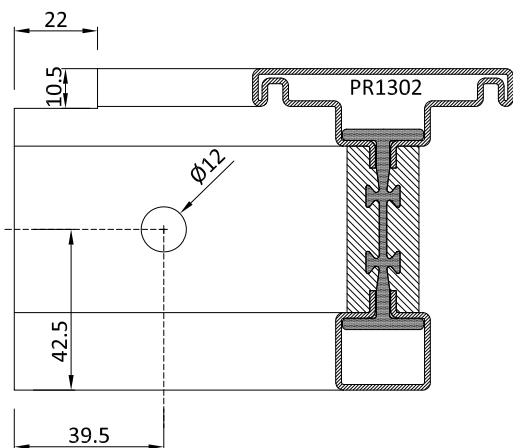
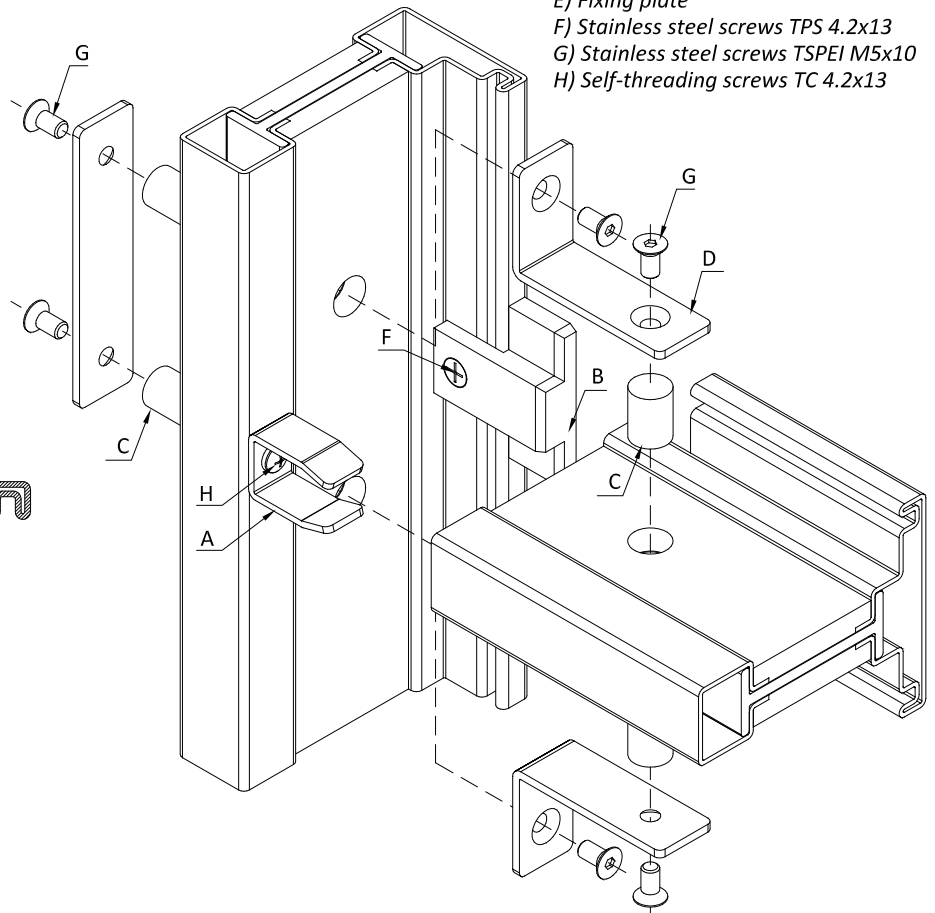
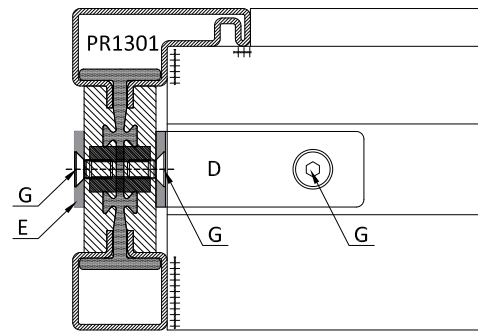
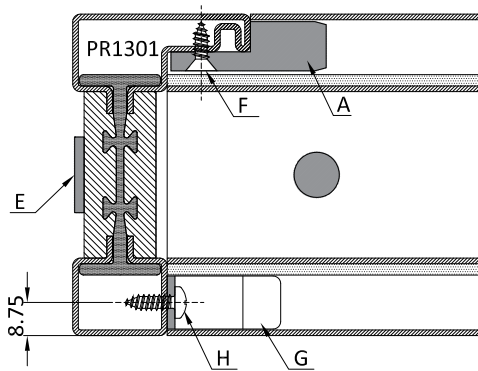

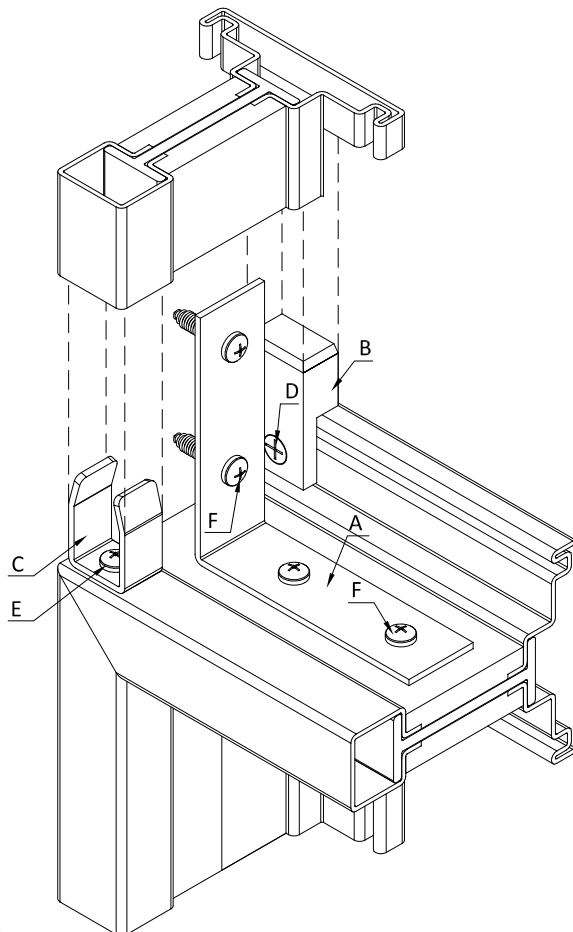
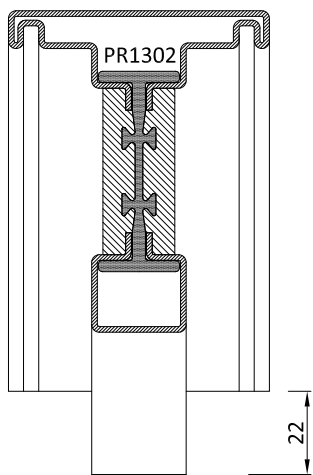
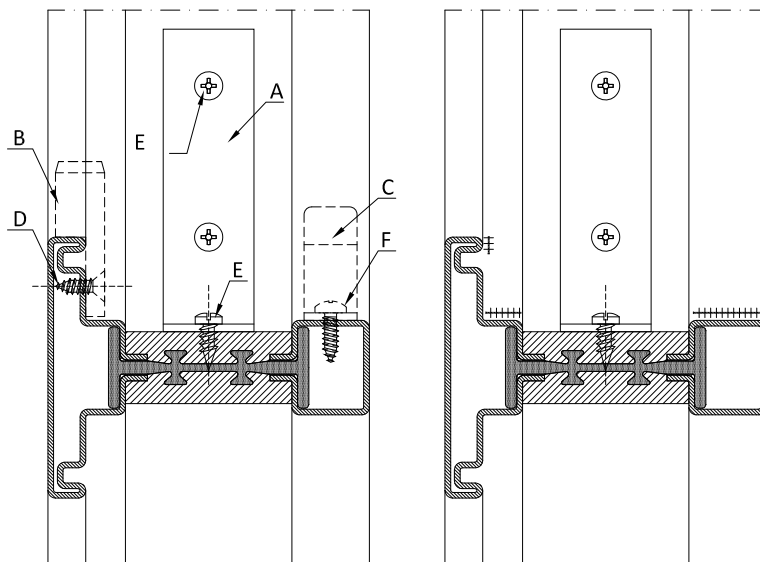
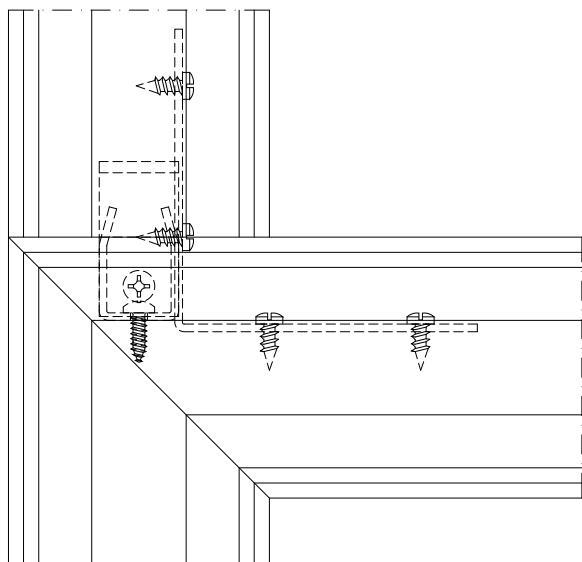
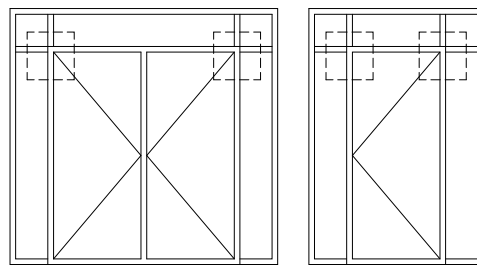
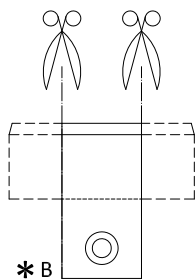
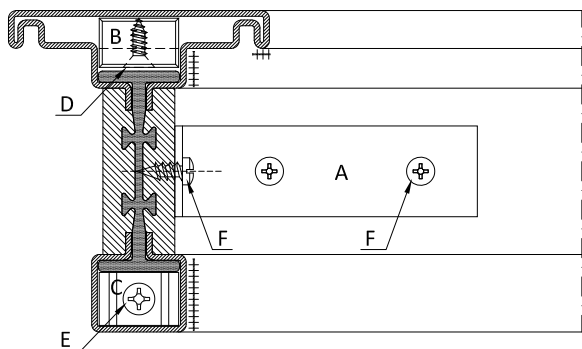

Saldare a TIG con materiale di riporto nelle zone indicate con +++++

TIG welding with filler material in the areas indicated with +++++

Sigillare tutte le superfici di contatto con silicone o SL0019

Seal all the external contact surfaces with silicone or SL0019

- A) Squadretta giunzione 90°
- B) Cavallotto di allineamento lato esterno
- C) Cavallotto di allineamento lato interno
- D) Vite acciaio inox TPS 4.2x13
- E) Vite autofilettante TC 4.2x13
- F) Vite autofilettante TE 4.8x20

- A) Corner bracket 90°
- B) U-bolt for alignment outer side
- C) U-bolt for alignment inner side
- D) Stainless steel screws TPS 4.2x13
- E) Self-threading screws TC 4.2x13
- F) Self-threading screws TE 4.8x20

* Tagliare le alette del cavallotto B come da disegno

* Angles of U-connection piece B have to be cut according the drawing

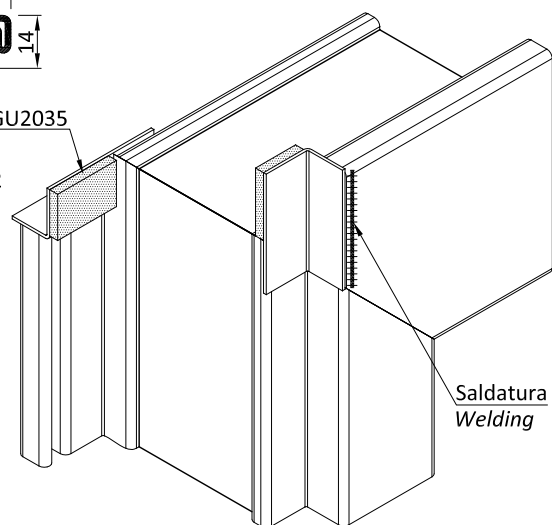
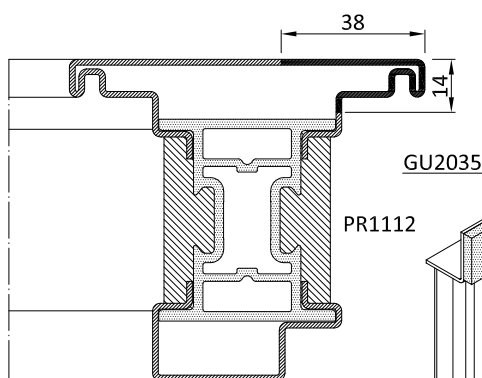
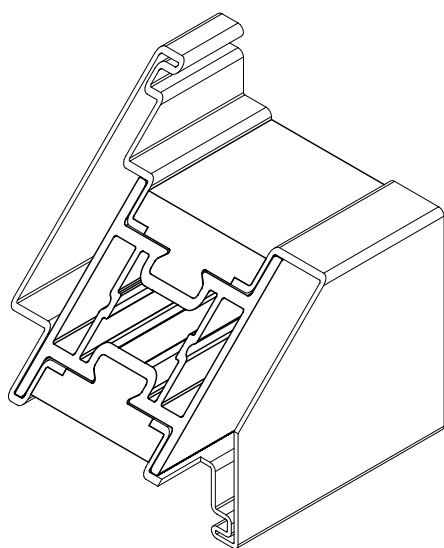
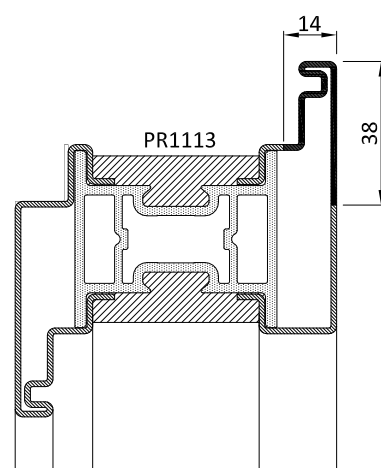
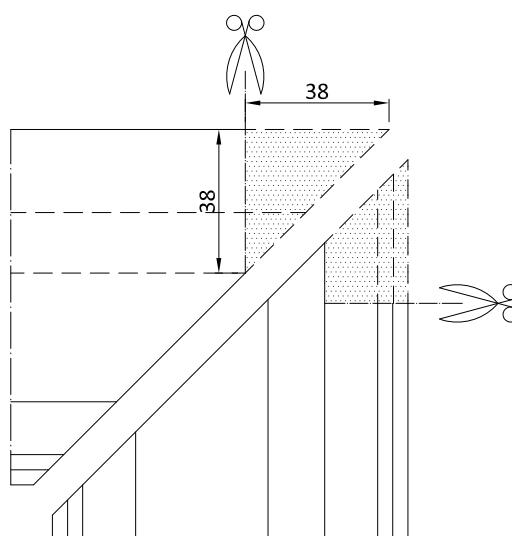
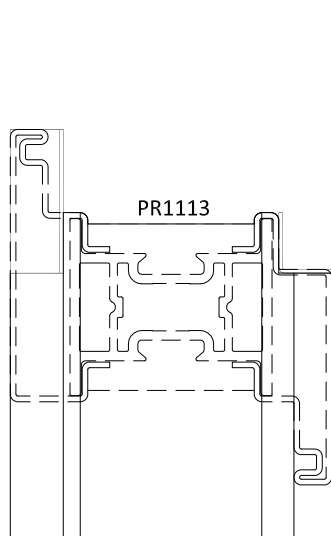
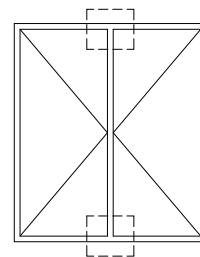
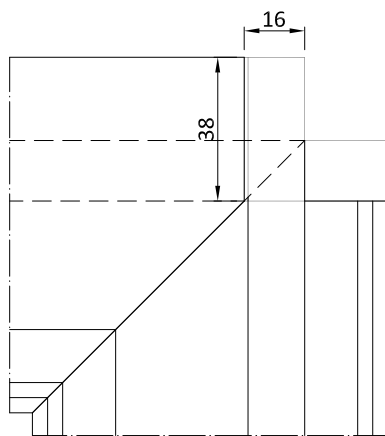
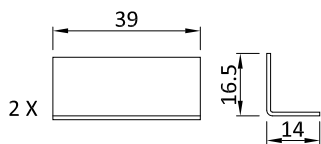

Nota: Saldare e sigillare l'accessorio secondo la tipologia e la mano di apertura

Note: Weld and seal the AC1014 according to the typology and the hand of opening

Nota: i fondini sono forniti di dimensioni maggiori da rifilare dopo la saldatura

Note: strike plates are provided with larger dimensions. They have to be trimmed after welding

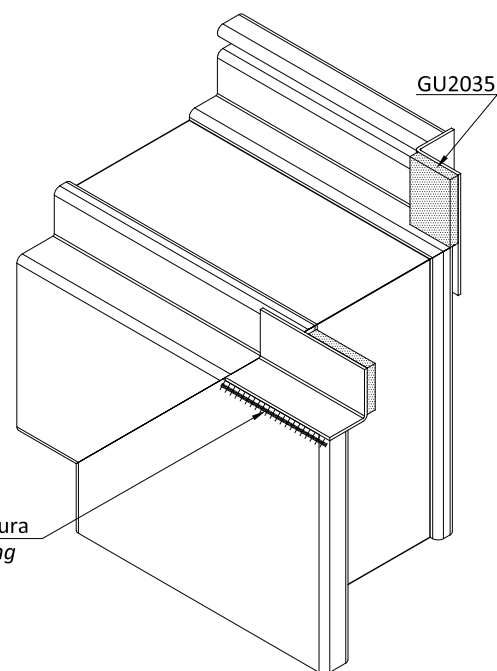
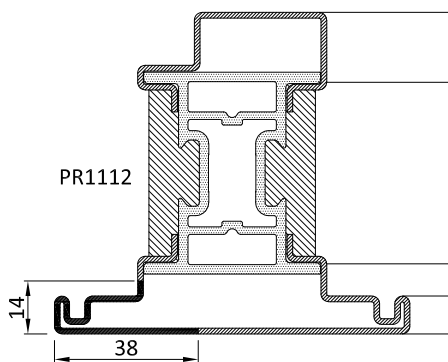
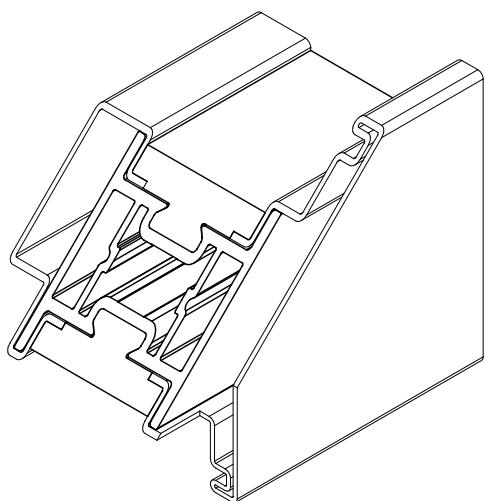
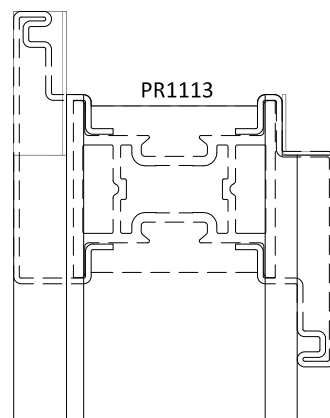
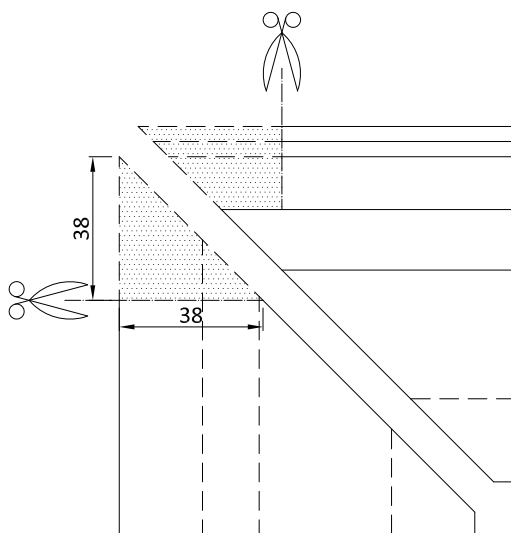
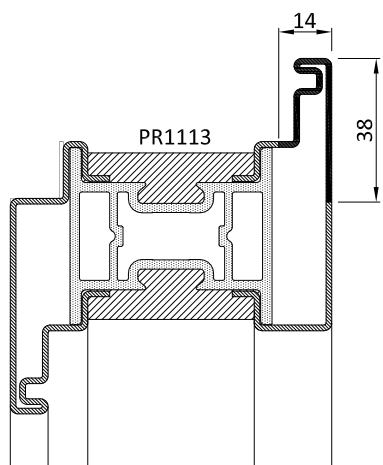
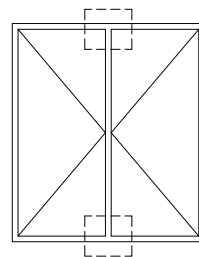
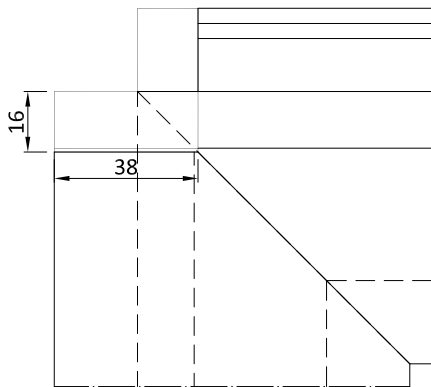
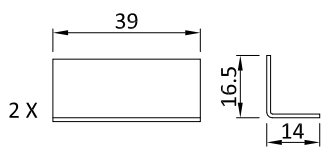

Nota: Saldare e sigillare l'accessorio secondo la tipologia e la mano di apertura
Note: Weld and seal the AC1014 according to the typology and the hand of opening

Nota: i fondini sono forniti di dimensioni maggiori da rifilare dopo la saldatura
Note: strike plates are provided with larger dimensions. They have to be trimmed after welding

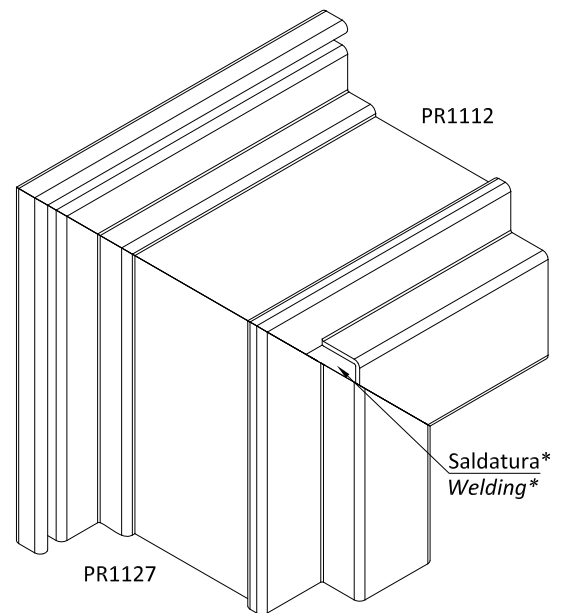
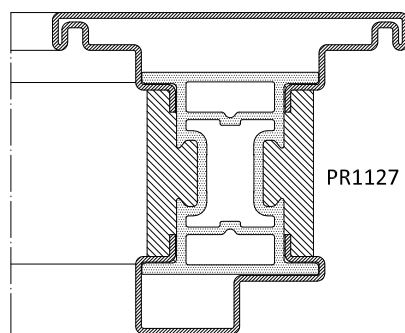
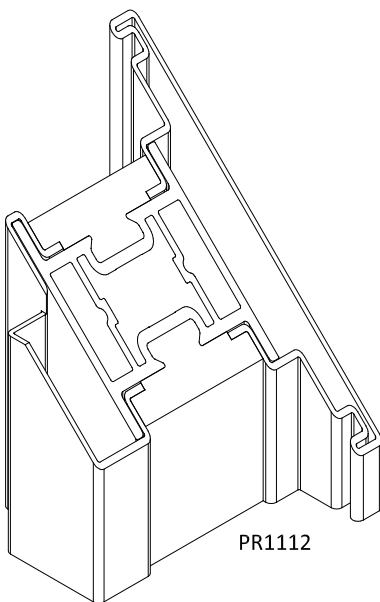
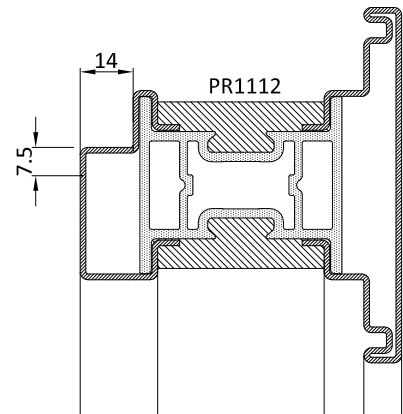
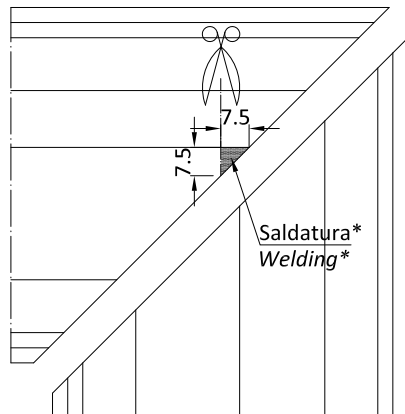
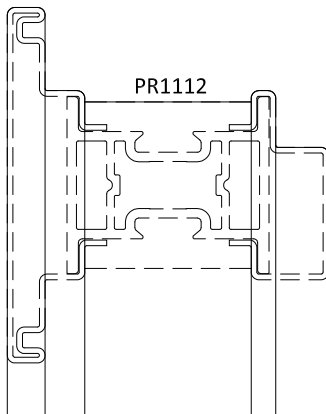
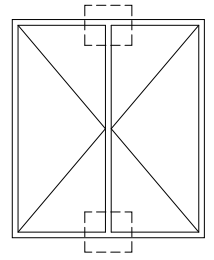
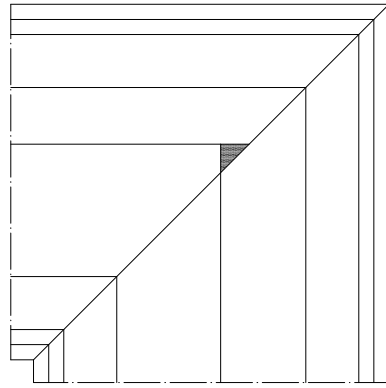

* Saldare con materiale di riporto
* Welding with filler material

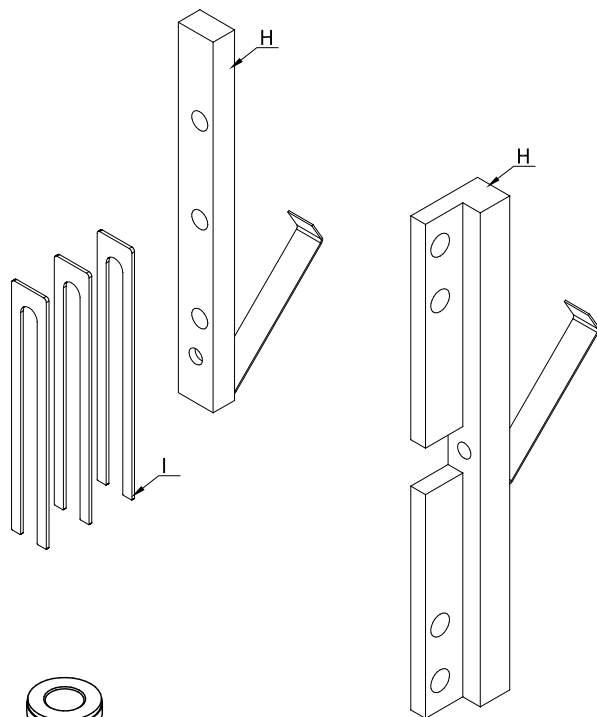
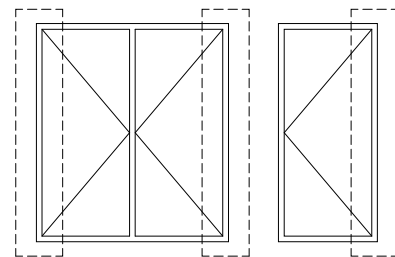

- A) Corpo cerniera A
- B) Corpo cerniera B
- C) Perno
- D) Distanziatore
- E) Tappo a vite
- F) Boccola antifrizione
- G) Distanziatore
- H) Rinforzi interni
- I) Distanziale di regolazione
- L) Viti acciaio inox TSPEI M6 x 16
- M) Vite acciaio inox testa a bottone M6 x 10
- N) Spina inox Ø 6 x 10 da inserire dopo la regolazione dell'anta
- O) Grano M5 x 6

- A) Body of the hinge A
- B) Body of the hinge B
- C) Pin
- D) Spacer
- E) Screw cap
- F) Antifriction bushing
- G) Spacer
- H) Internal reinforcements
- I) Regulating spacer
- L) Stainless steel screws TSPEI M6 x 16
- M) Stainless steel button head screws M6 x 10
- N) Stainless steel pin Ø 6 x 10 to insert after regulating the leaf
- O) Dowel M5x6

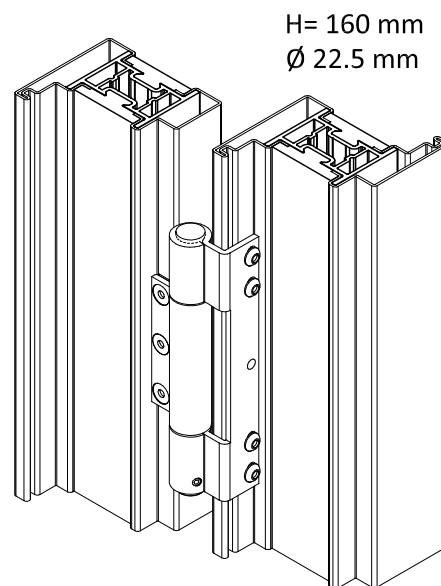
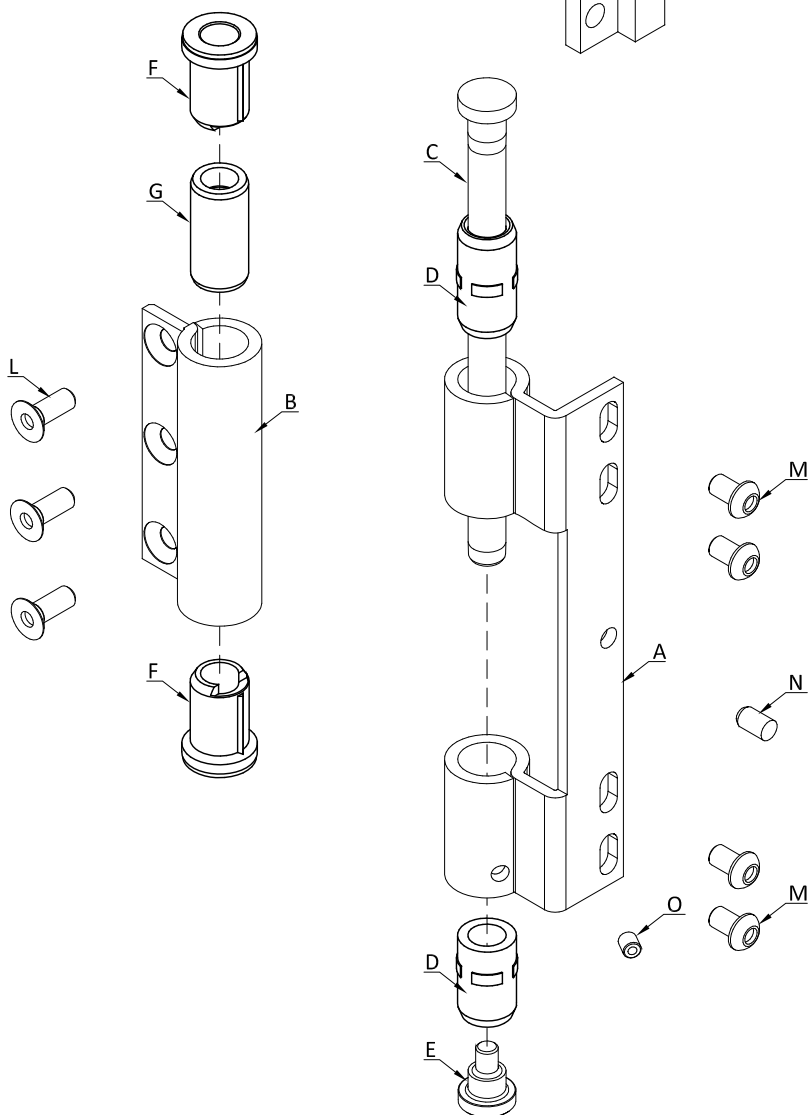

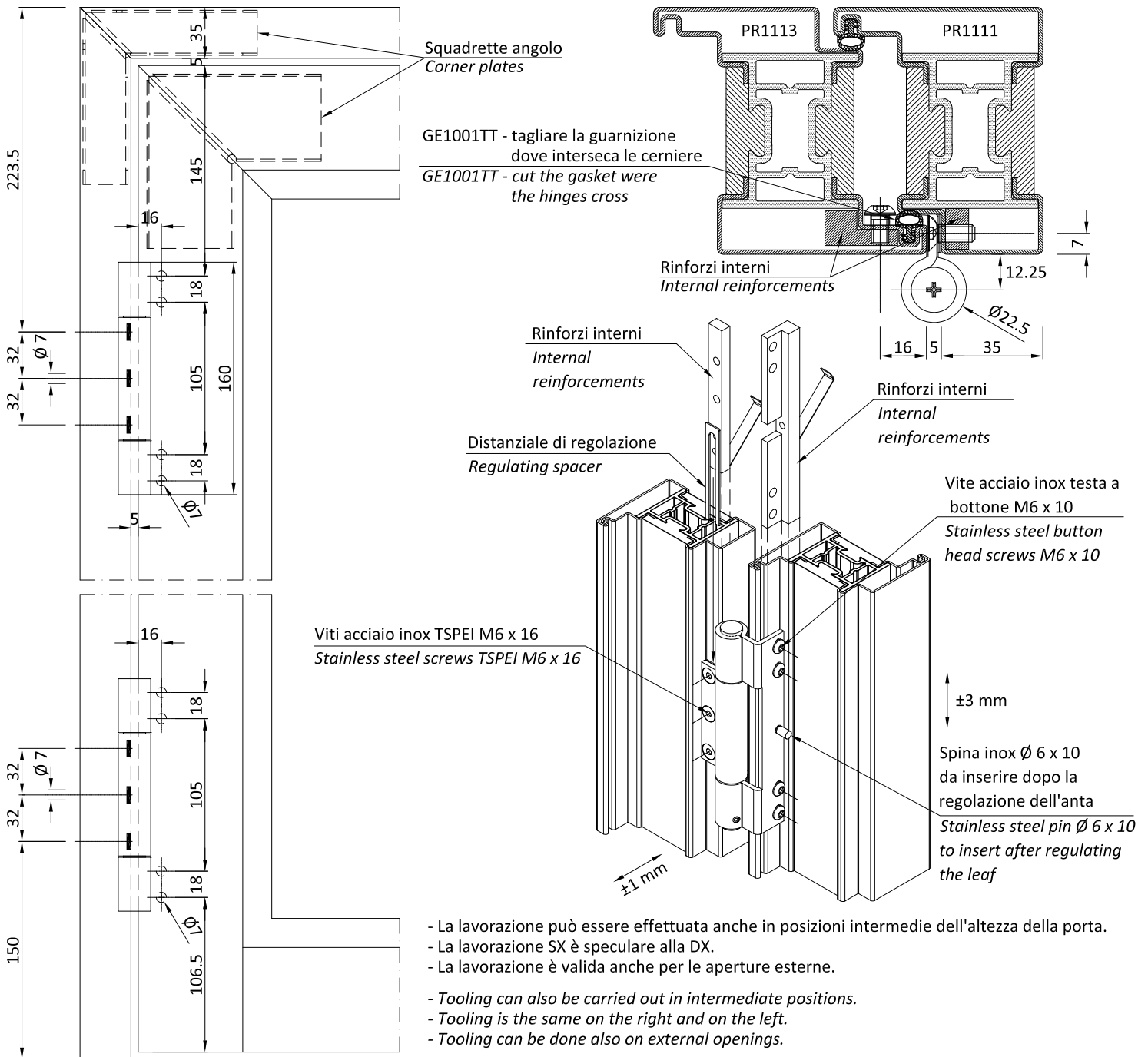
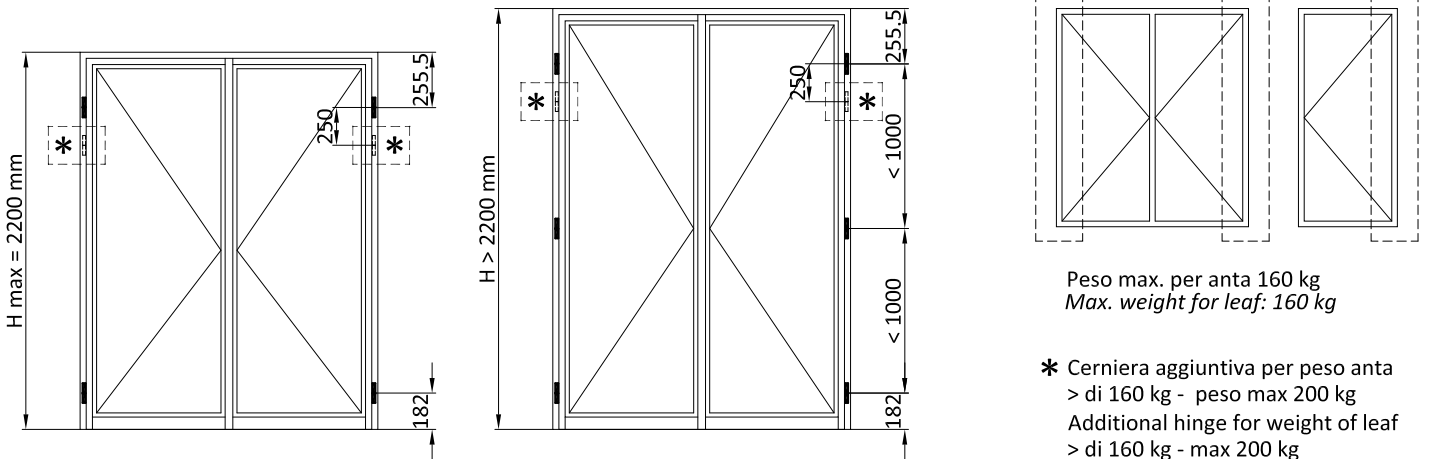

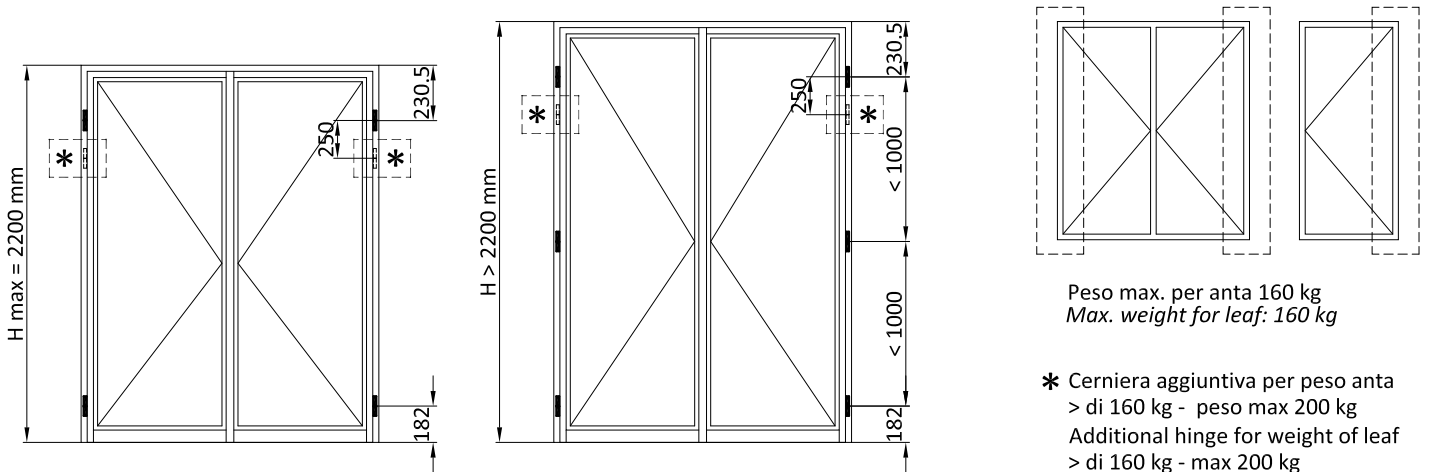

* Cerniera aggiuntiva per peso anta > di 160 kg - peso max 200 kg
Additional hinge for weight of leaf > di 160 kg - max 200 kg

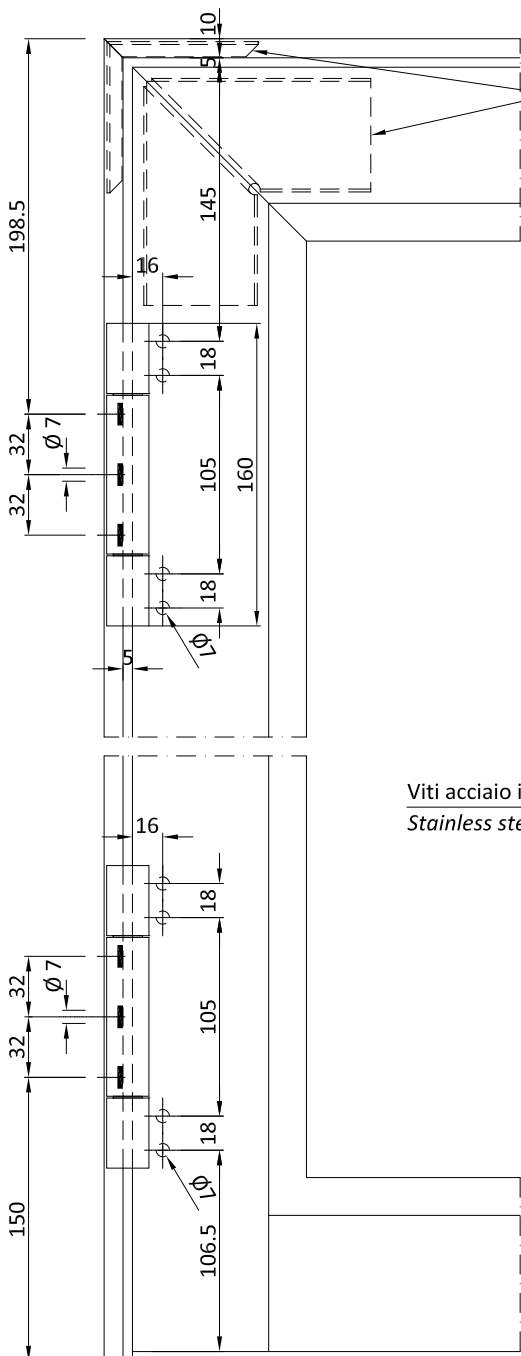

Squadrette angolo
Corner plates

GE1001TT - tagliare la guarnizione dove interseca le cerniere
GE1001TT - cut the gasket where the hinges cross

Rinforzi interni
Internal reinforcements

Distanziale di regolazione
Regulating spacer

Viti acciaio inox TSPEI M6 x 16
Stainless steel screws TSPEI M6 x 16

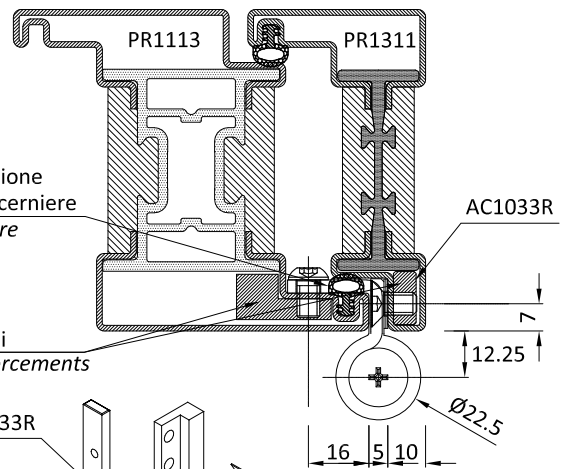

AC1033R

Rinforzi interni
Internal stiffeners

Vite acciaio inox testa a bottone M6 x 10
Stainless steel button head screws M6 x 10

±3 mm

Spina inox Ø 6 x 10 da inserire dopo la regolazione dell'anta
Stainless steel pin Ø 6 x 10 to insert after regulating the leaf

±1 mm

- La lavorazione può essere effettuata anche in posizioni intermedie dell'altezza della porta.
- La lavorazione SX è speculare alla DX.
- La lavorazione è valida anche per le aperture esterne.
- *Tooling can also be carried out in intermediate positions.*
- *Tooling is the same on the right and on the left.*
- *Tooling can be done also on external openings.*

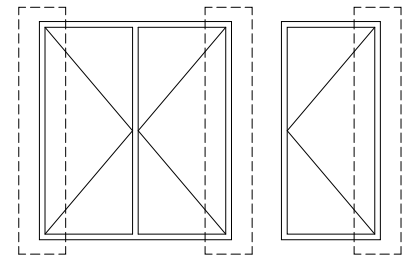
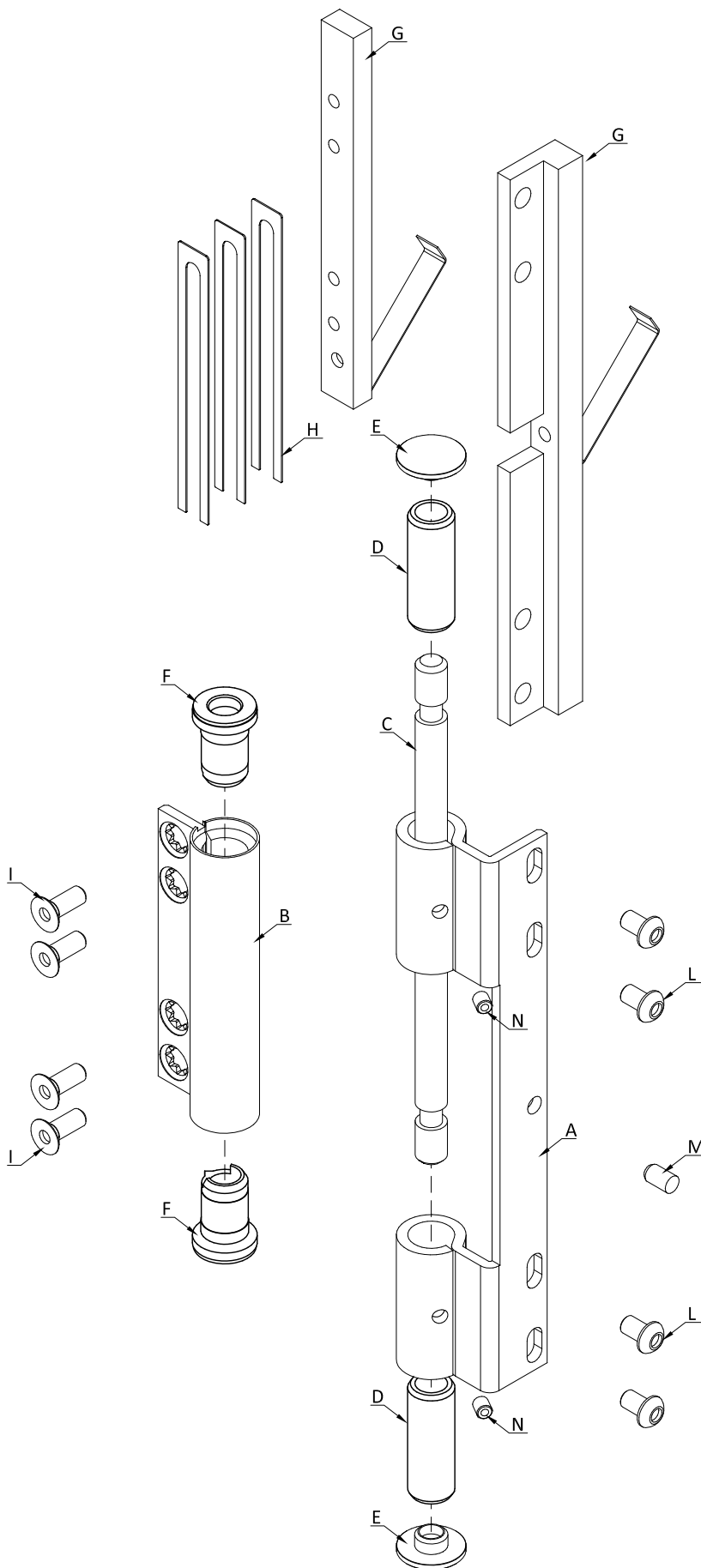

- A) Corpo cerniera A
- B) Corpo cerniera B
- C) Perno
- D) Distanziatore
- E) Tappo di finitura
- F) Boccola antifrizione
- G) Rinforzi interni
- H) Distanziale di regolazione
- I) Viti acciaio inox TSPEI M6 x 16
- L) Vite acciaio inox testa a bottone M6 x 10
- M) Spina inox $\varnothing 6 \times 10$ da inserire dopo la regolazione dell'anta
- N) Grano M5 x 6

- A) Body of the hinge A
- B) Body of the hinge B
- C) Pin
- D) Spacer
- E) Ending cap
- F) Antifriction bushing
- G) Internal reinforcements
- H) Regulating spacer
- I) Stainless steel screws TSPEI M6 x 16
- L) Stainless steel button head screws M6 x 10
- M) Stainless steel pin $\varnothing 6 \times 10$ to insert after regulating the leaf
- N) Dowel M5x6

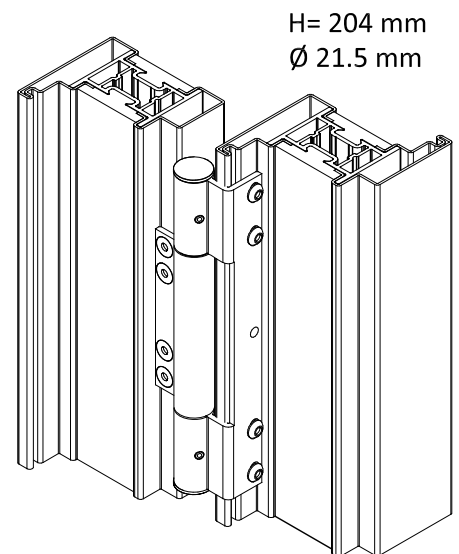

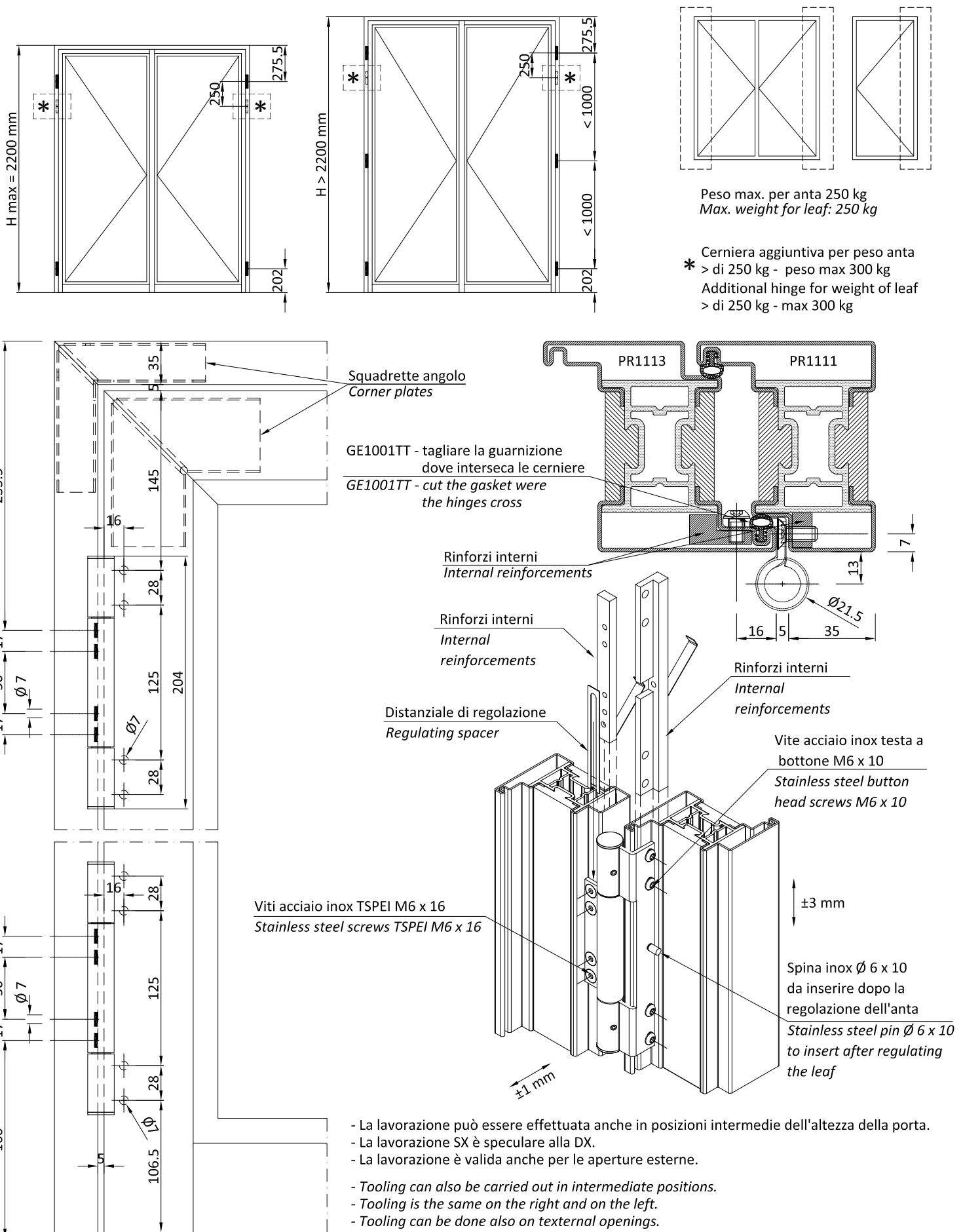

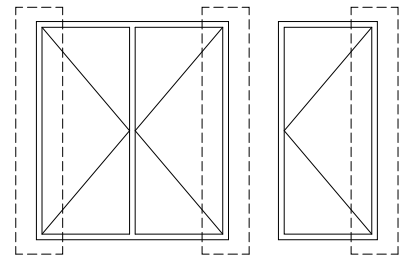
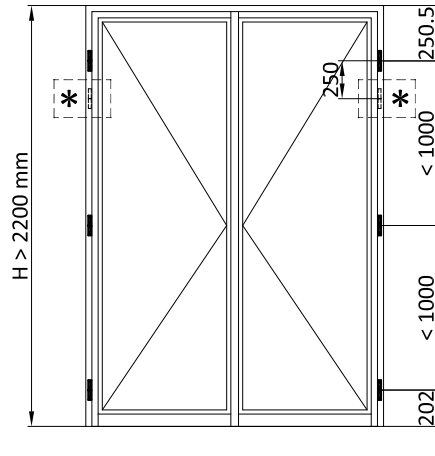
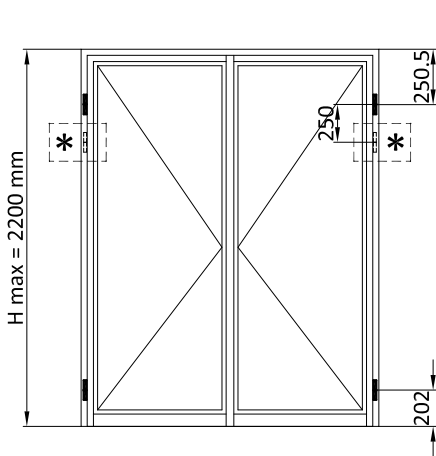

Peso max. per anta 250 kg
Max. weight for leaf: 250 kg

* Cerniera aggiuntiva per peso anta > di 250 kg - peso max 300 kg
Additional hinge for weight of leaf > di 250 kg - max 300 kg

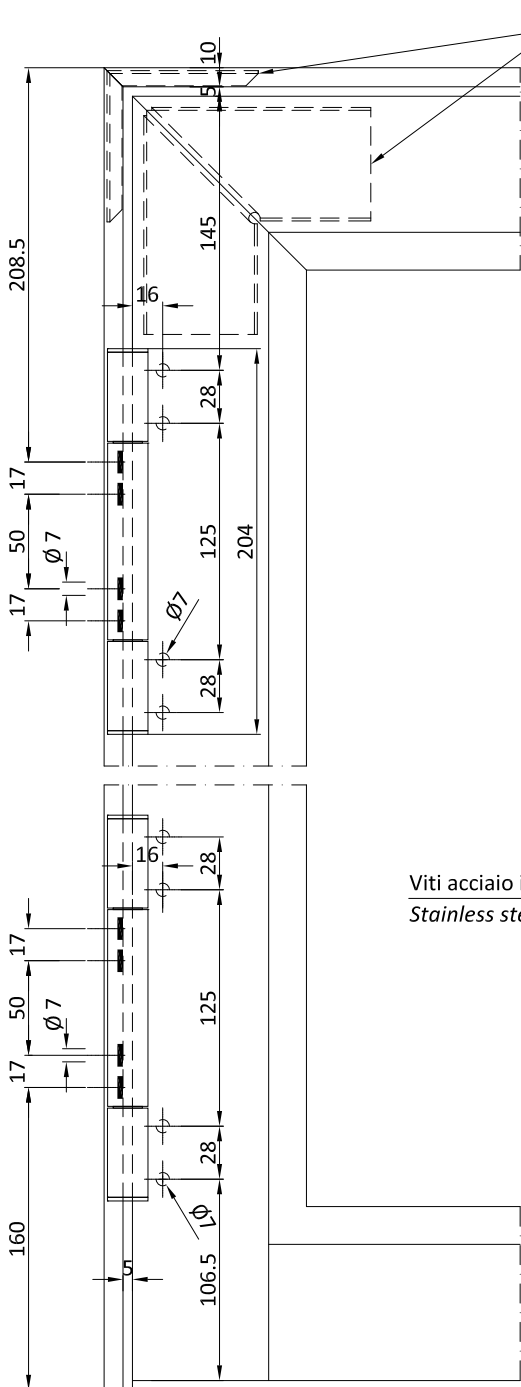

Squadrette angolo
Corner plates

GE1001TT - tagliare la guarnizione dove interseca le cerniere
GE1001TT - cut the gasket were the hinges cross

Rinforzi interni
Internal reinforcements

Distanziale di regolazione
Regulating spacer

Viti acciaio inox TSPEI M6 x 16
Stainless steel screws TSPEI M6 x 16

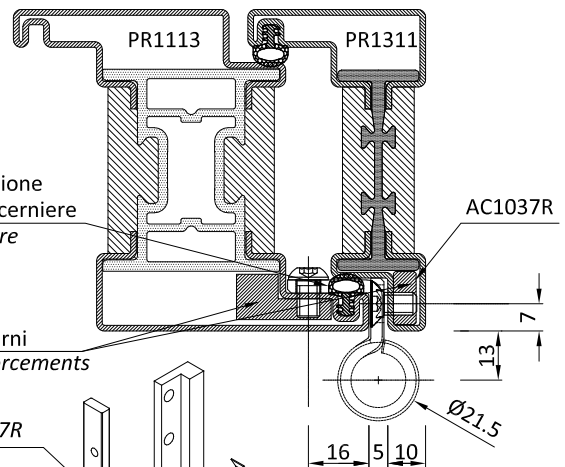

AC1037R

Rinforzi interni
Internal reinforcements

Vite acciaio inox testa a bottone M6 x 10
Stainless steel button head screws M6 x 10

±3 mm

Spina inox Ø 6 x 10 da inserire dopo la regolazione dell'anta
Stainless steel pin Ø 6 x 10 to insert after regulating the leaf

±1 mm

- La lavorazione può essere effettuata anche in posizioni intermedie dell'altezza della porta.
- La lavorazione SX è speculare alla DX.
- La lavorazione è valida anche per le aperture esterne.
- Tooling can also be carried out in intermediate positions.
- Tooling is the same on the right and on the left.
- Tooling can be done also on external openings.



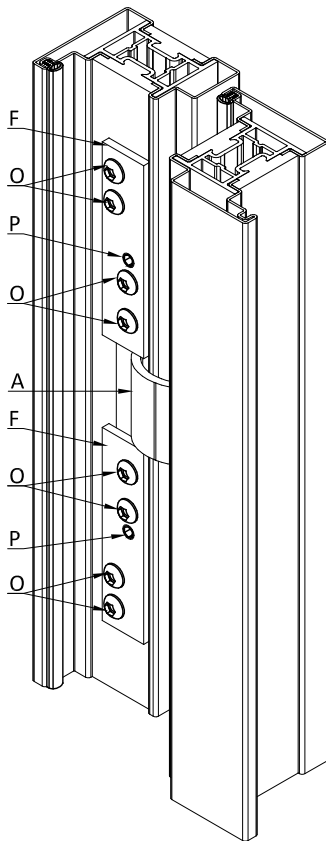

- A) Corpo cerniera A
- B) Corpo cerniera B
- C) Perno
- D) Cuscinetto
- E) Seger
- F) Piastra
- G) Contro-piastra A
- H) Contro-piastra B
- I) Spessore
- L) Staffa di fissaggio
- M) Contropiastra C
- N) n°2 x Vite TPEI M8x12 mm
- O) n°10 x Vite TCEI M8x30 mm
- P) Grano M10x25 mm punta conica

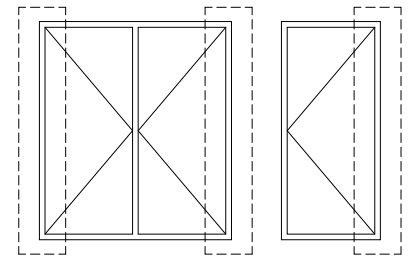

- A) Body hinge A
- B) Body hinge B
- C) Pin
- D) Bearing
- E) Seger
- F) Plate
- G) Retainer plate A
- H) Retainer plate B
- I) Shim
- L) Anchoring bracket
- M) Counter-plate C
- N) n° 2 x Screws TPEI M8x12 mm
- O) n°10 x Screws TCEI M8x30 mm
- P) Dowel M10x25mm cone point

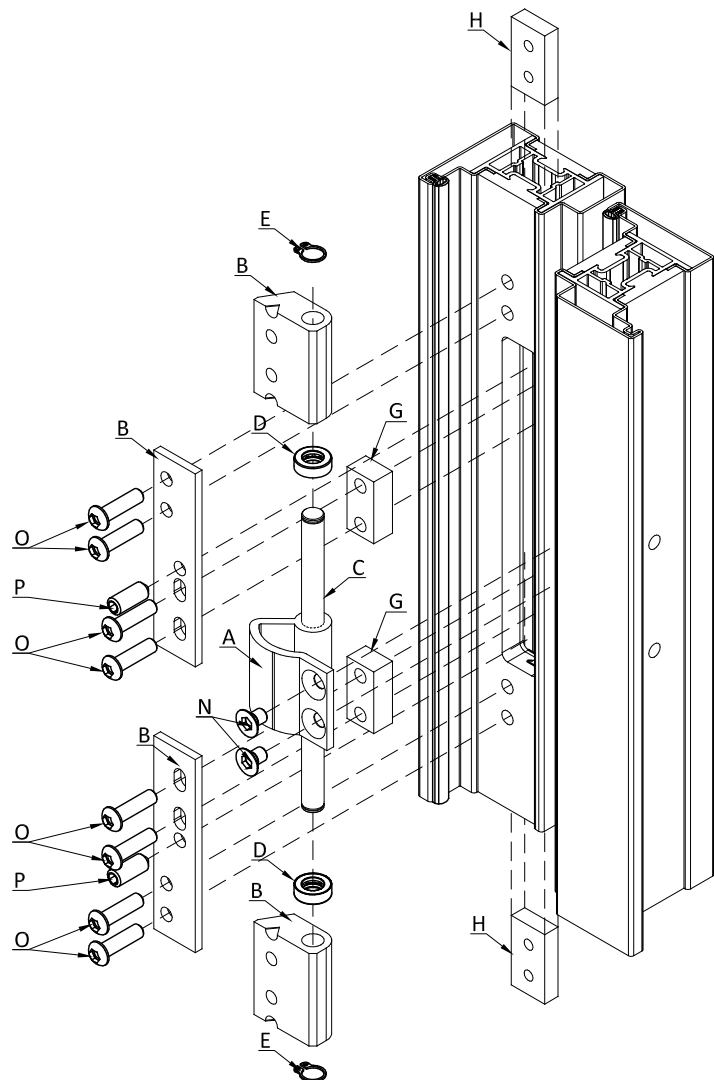
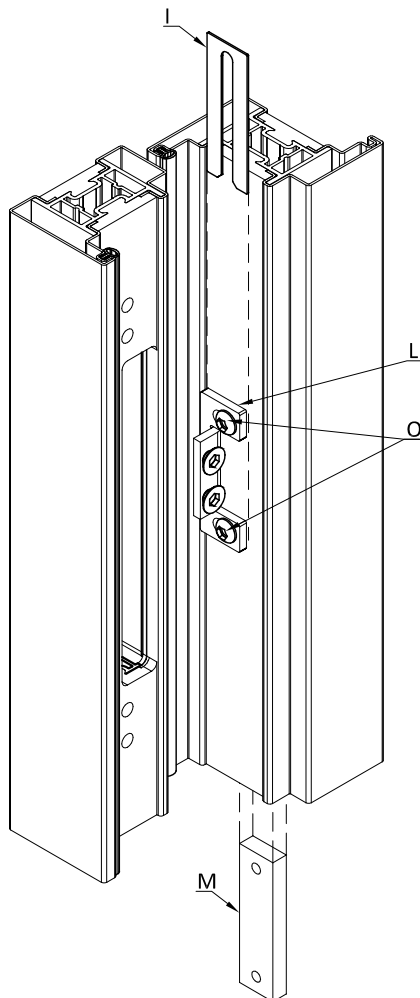

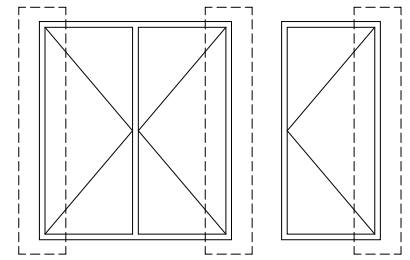
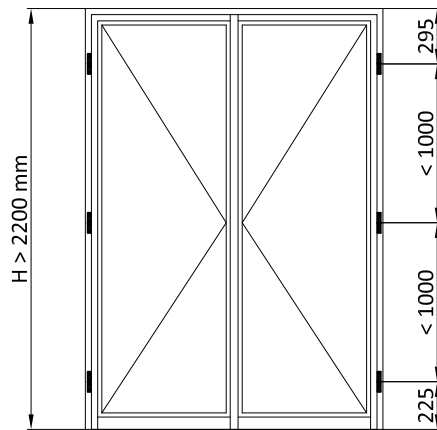
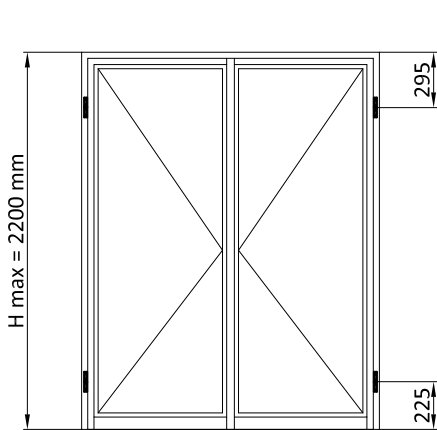

Peso max. per anta 180 kg
Massima apertura 96°
Max. weight for leaf: 180 kg
Maximum opening 96°

Lavorazione eseguibile con fresa AT1068
Tooling possible with milling cutter AT1068

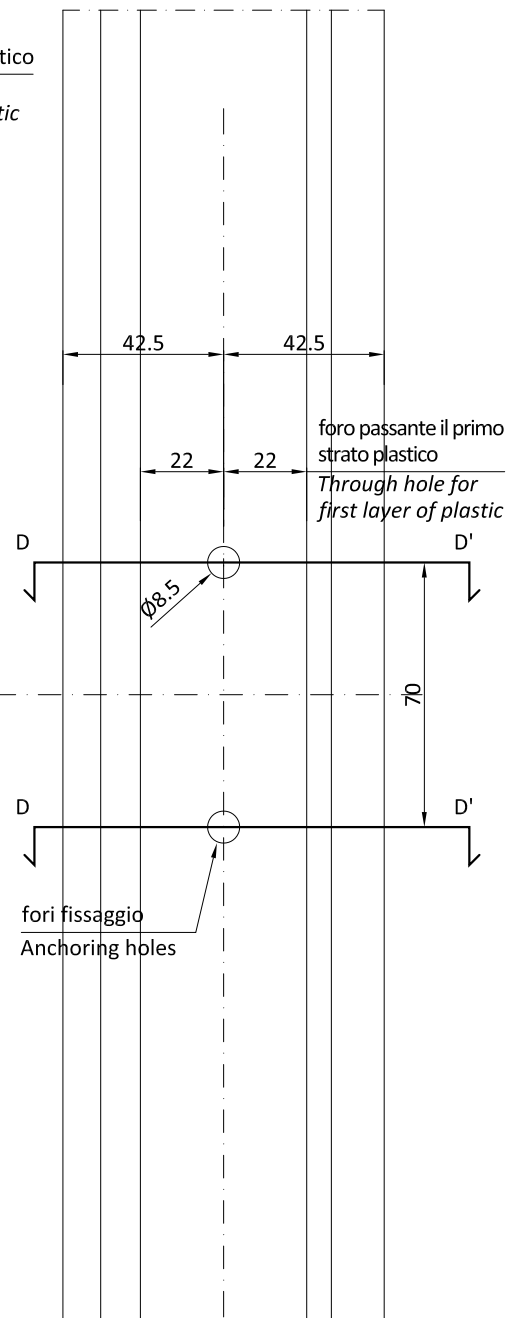
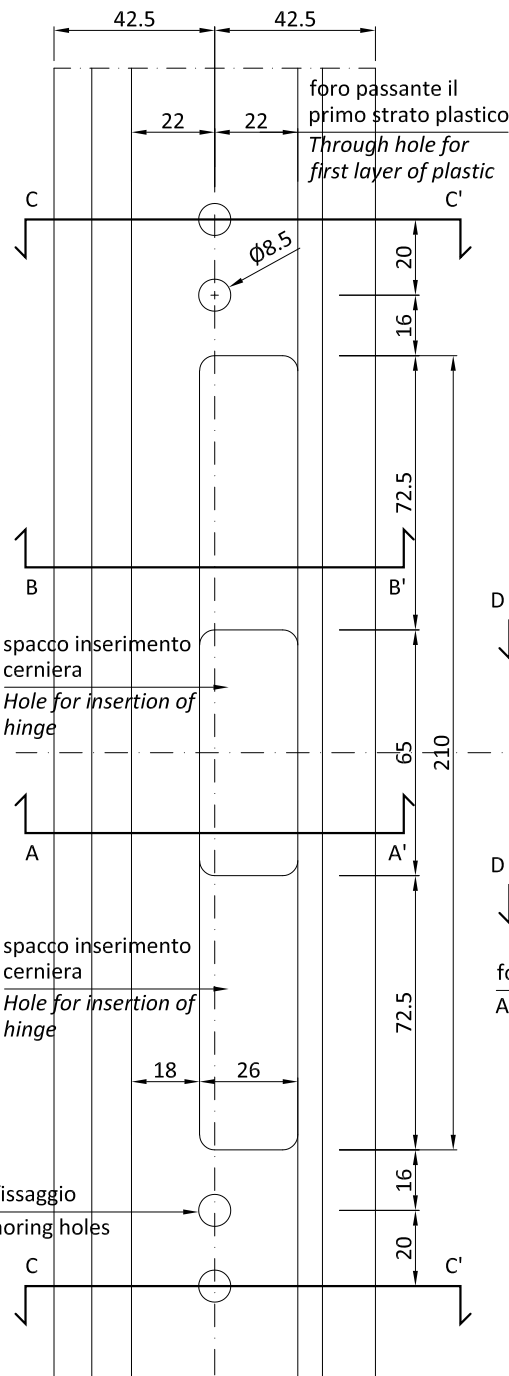
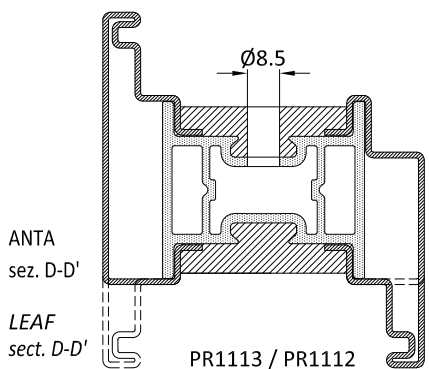
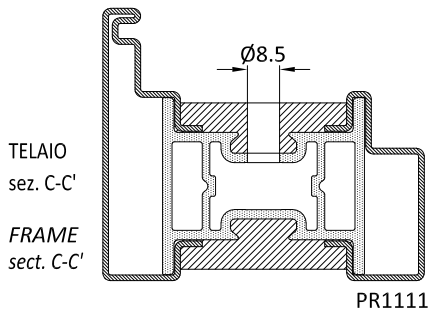
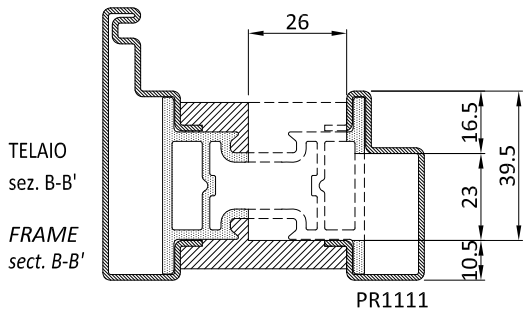
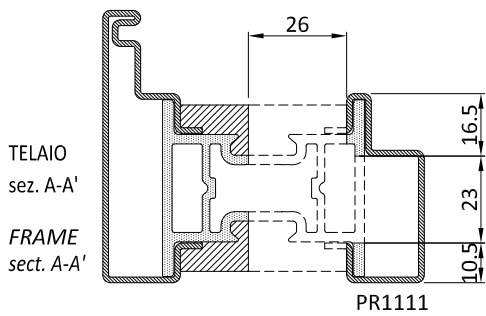

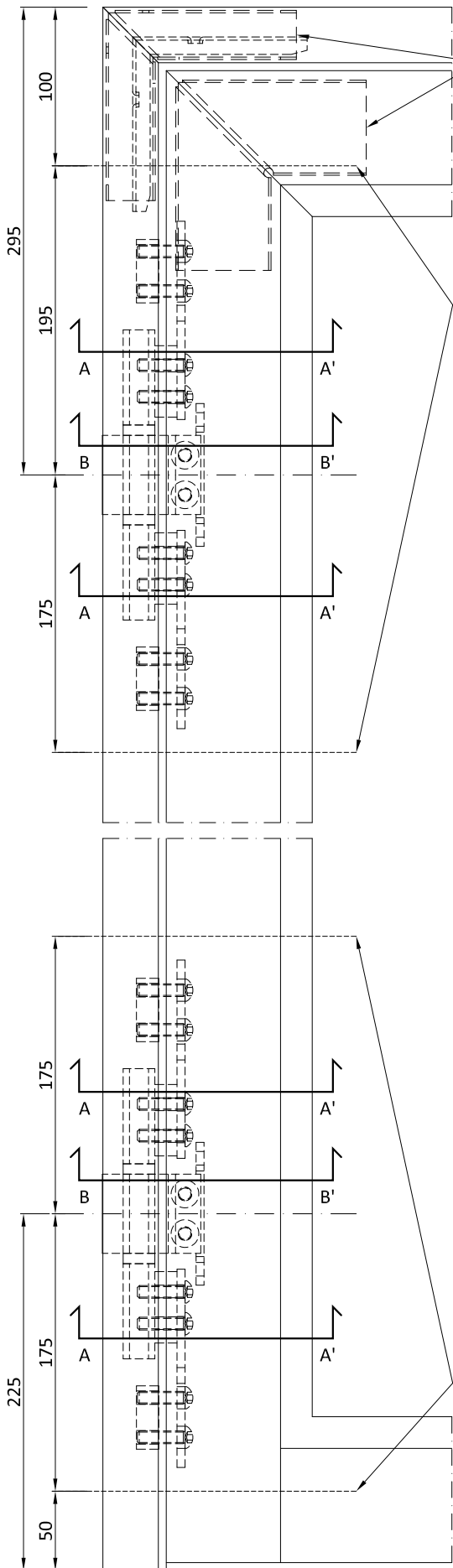

Squadrette angolo
Corner plates

Fissaggio a muro
Anchoring to the wall

Fissaggio a muro
Anchoring to the wall

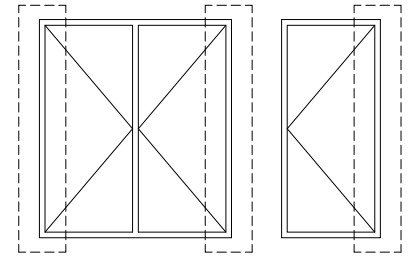

Peso max. per anta 180 kg
Massima apertura 96°
Max. weight for leaf: 180 kg
Maximum opening 96°

Lavorazione eseguibile con fresa AT1068
Tooling possible with milling cutter AT1068

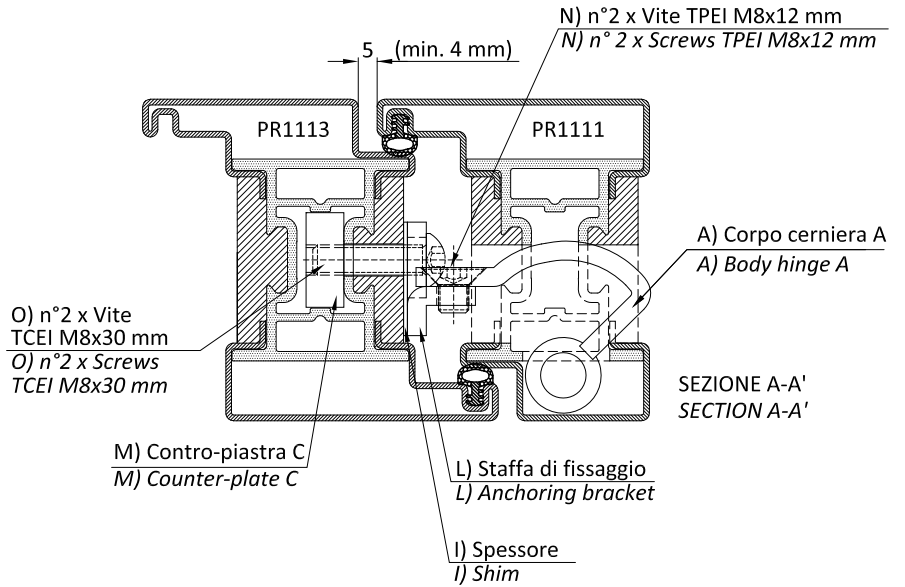

O) n°2 x Vite
TCEI M8x30 mm
O) n°2 x Screws
TCEI M8x30 mm

M) Contro-piastra C
M) Counter-plate C

L) Staffa di fissaggio
L) Anchoring bracket

I) Spessore
I) Shim

A) Corpo cerniera A
A) Body hinge A

SEZIONE A-A'
SECTION A-A'

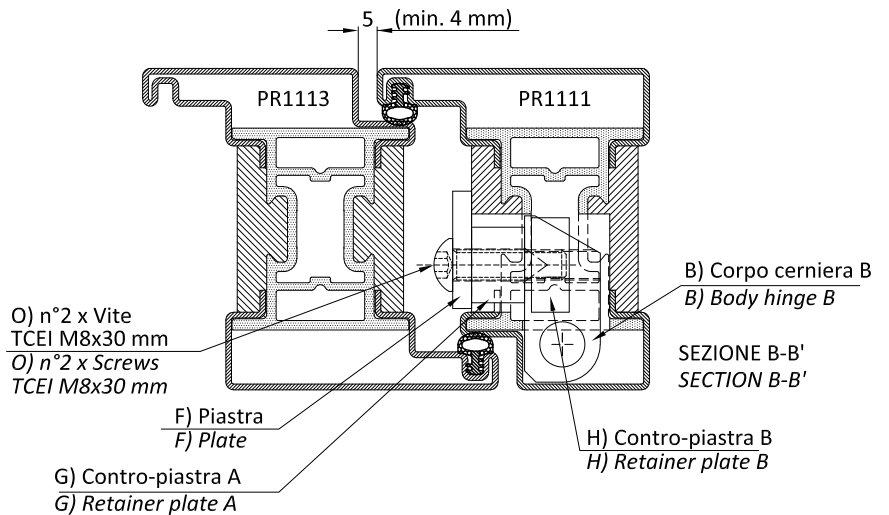

O) n°2 x Vite
TCEI M8x30 mm
O) n°2 x Screws
TCEI M8x30 mm

F) Piastra
F) Plate

G) Contro-piastra A
G) Retainer plate A

B) Corpo cerniera B
B) Body hinge B

SEZIONE B-B'
SECTION B-B'

H) Contro-piastra B
H) Retainer plate B

- La lavorazione può essere effettuata anche in posizioni intermedie dell'altezza della porta.
- La lavorazione SX è speculare alla DX.
- La lavorazione è valida anche per le aperture esterne.
- Tooling can also be carried out in intermediate positions.
- Tooling is the same on the right and on the left.
- Tooling can be done also on external openings.

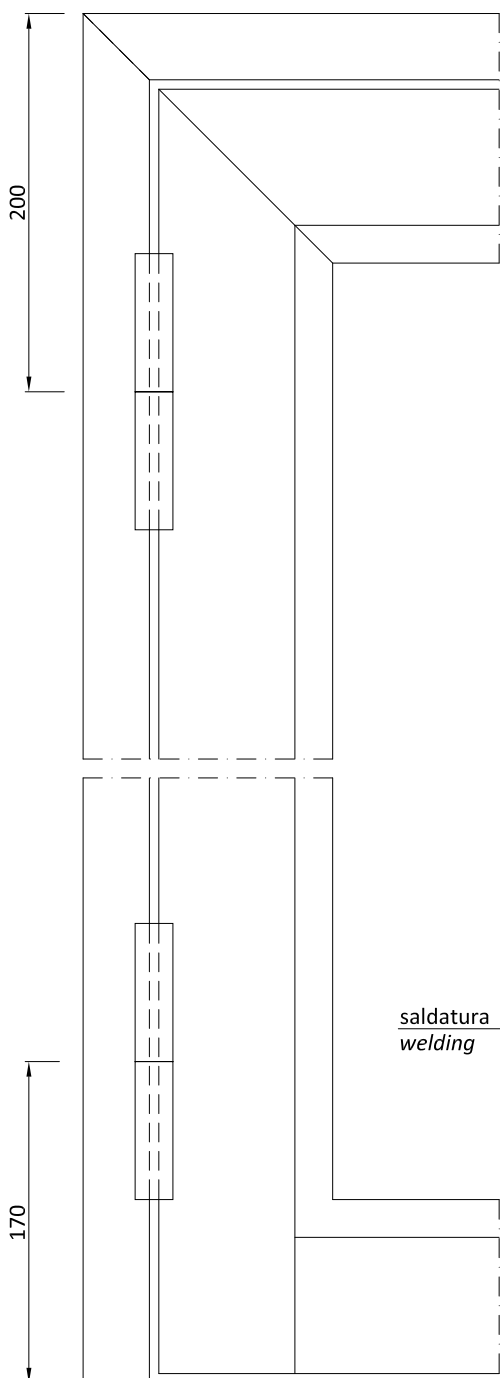
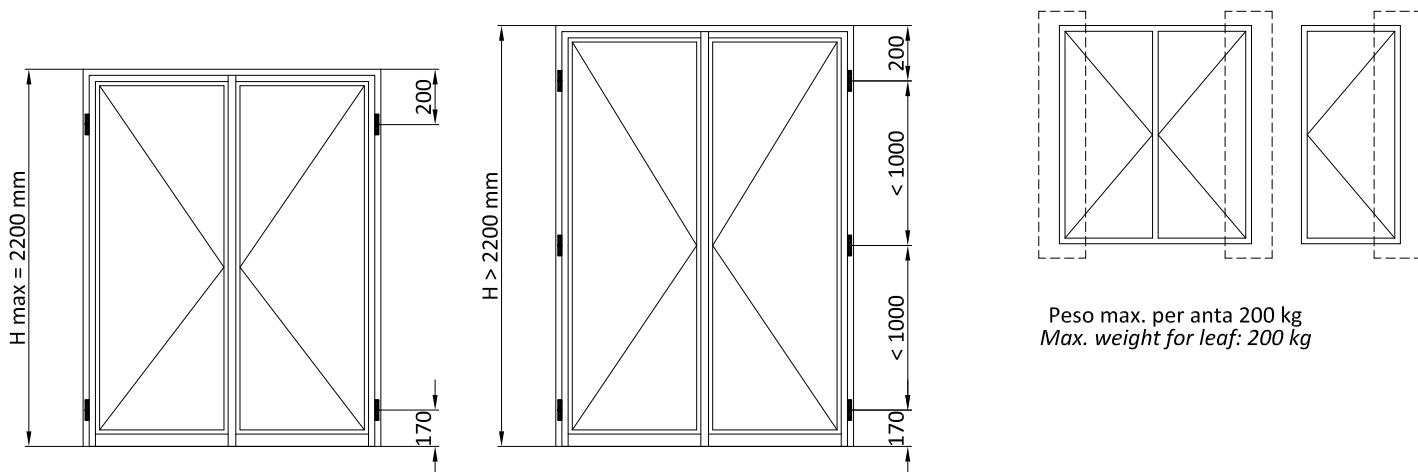

Posizionare le cerniere come da disegno saldandole sui lati.
Position the hinges as in the drawing, welding them on the sides.

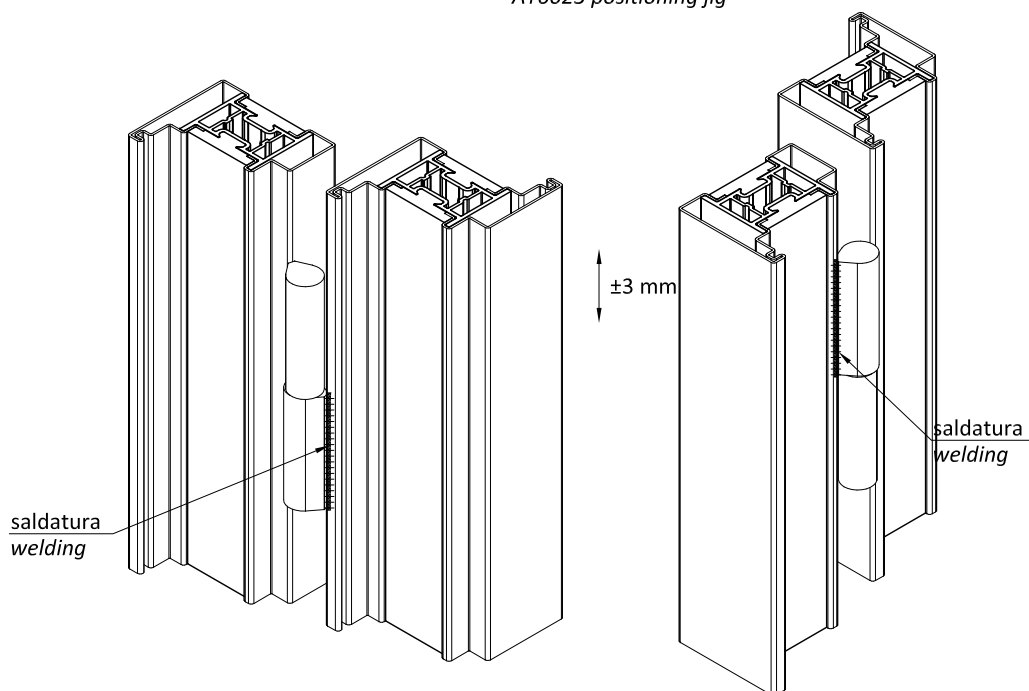
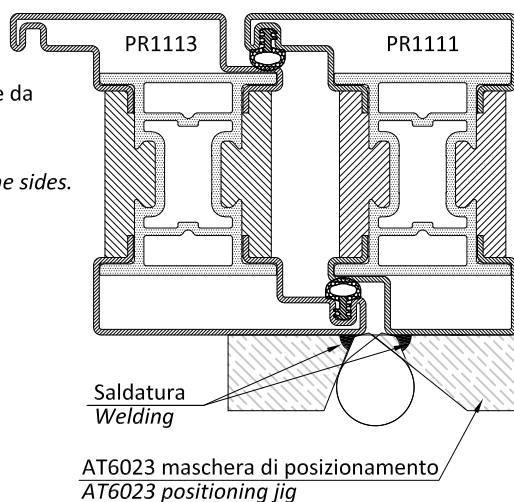

- La lavorazione può essere effettuata anche in posizioni intermedie dell'altezza della porta.
- La lavorazione SX è speculare alla DX.
- La lavorazione è valida anche per le aperture esterne.
- Tooling can be carried out also in intermediate positions regarding the height of the door.
- Tooling on left is the same as that on the right.
- Tooling can be done also on external openings.

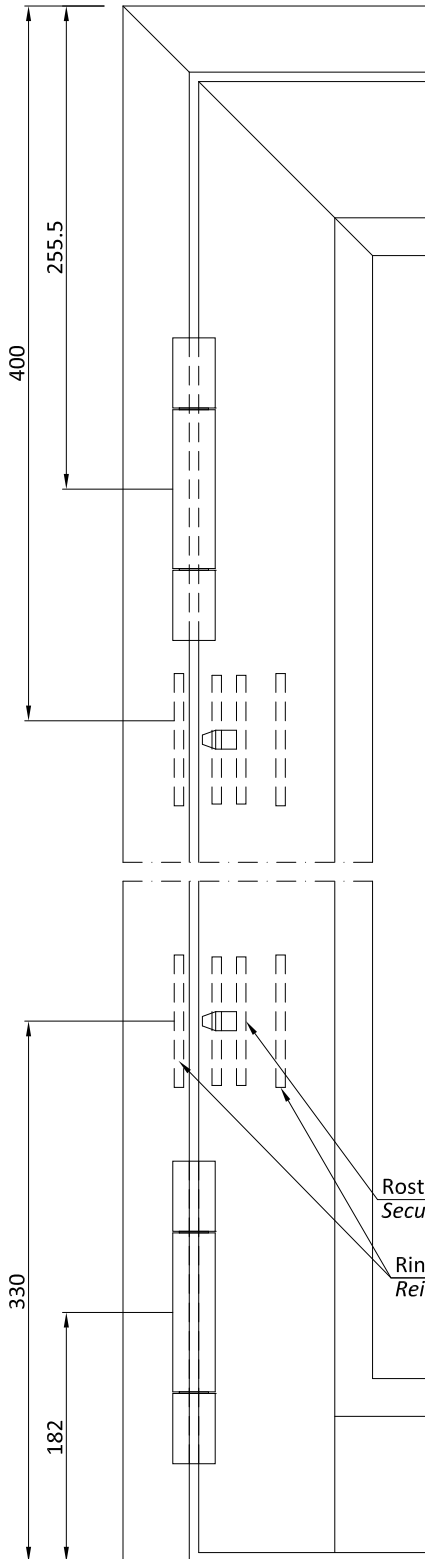
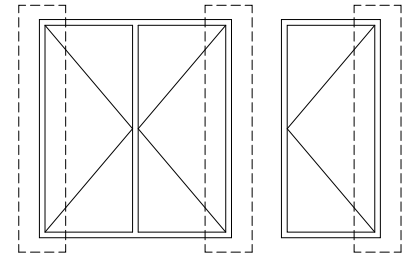
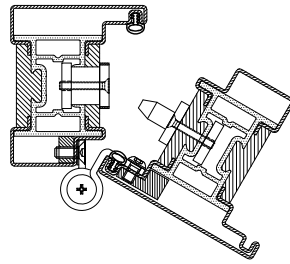
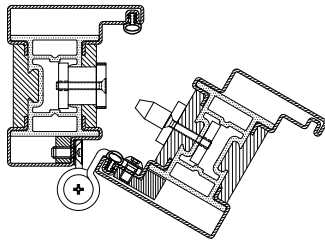

Rostro AC1080I
Security pin AC1080I

Rinforzo
Reinforcement

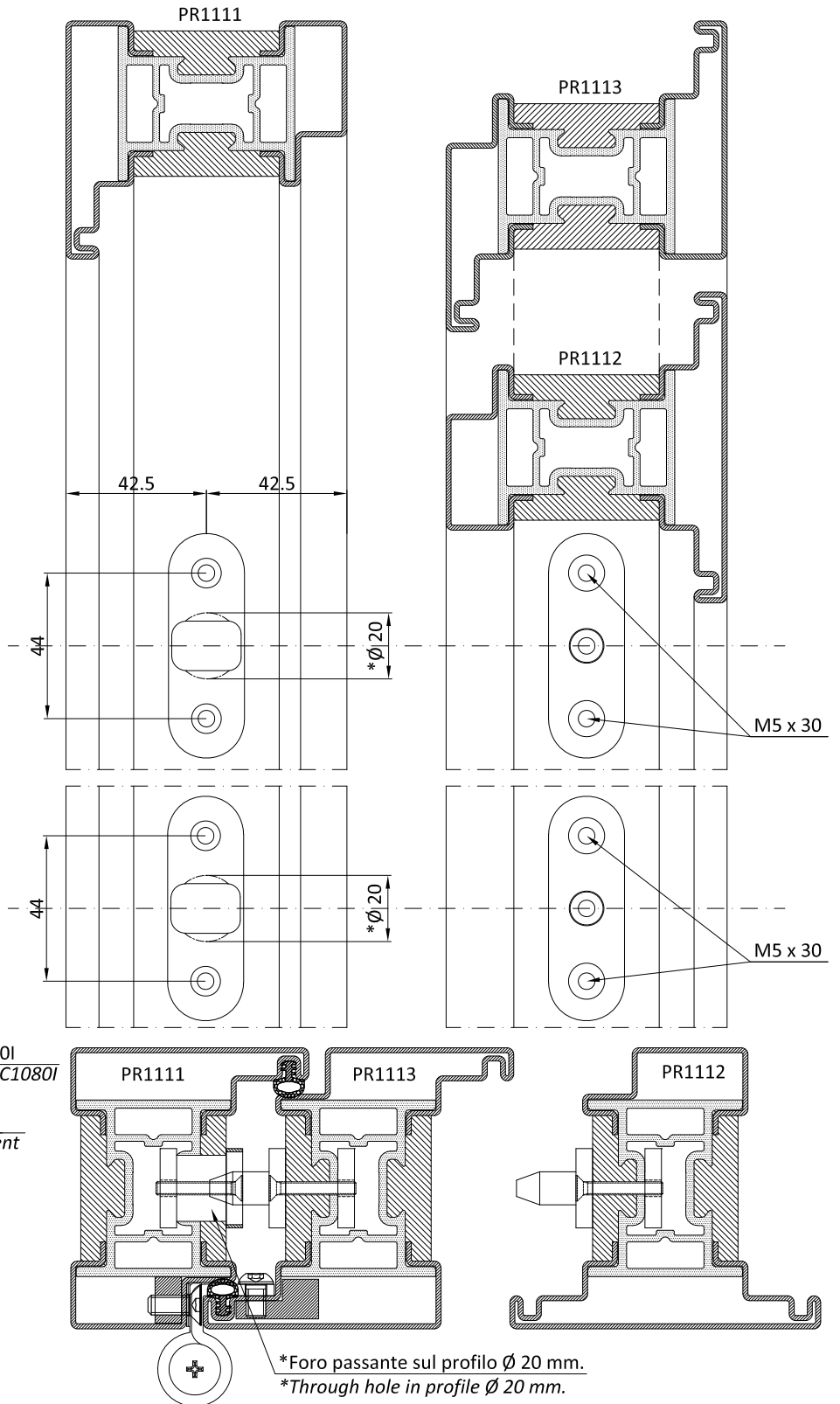

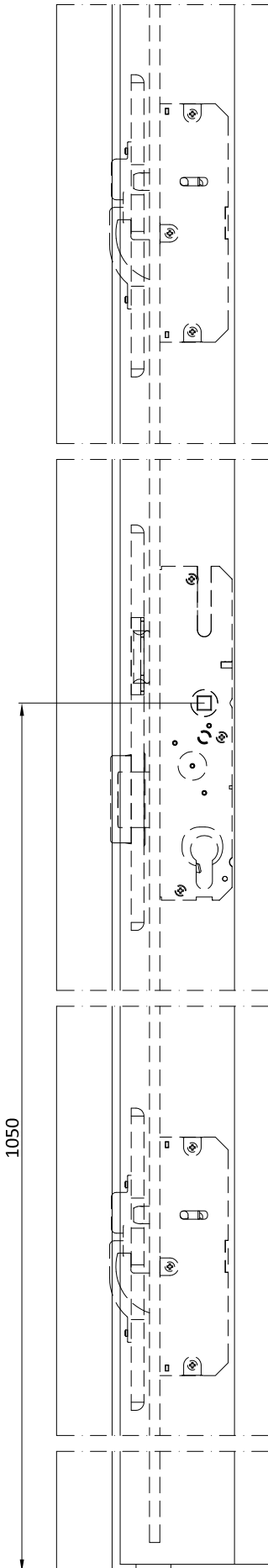

AC1065WD/S _ AC1066WD/S

- 1) Serratura
- 2) Frontalino
- 3) Scrocco
- 4) Catenaccio
- 5) Incontro per serratura
- 6) Deviatori (n°2 pezzi sup + inf.)
- 7) Catenaccio (n°2 pezzi sup + inf.)
- 8) Incontro (n°2 pezzi sup + inf.)

AC1065WD/S _ AC1066WD/S

- 1) Lock
- 2) Front plate
- 3) Spring latch
- 4) Bolt
- 5) Strike plate
- 6) Diverters (n° 2 items upper + lower)
- 7) Bolt (n° 2 items upper + lower)
- 8) Plate (no. 2 items upper + lower)

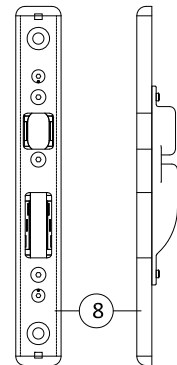
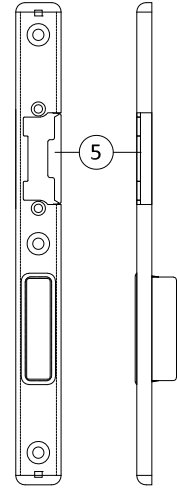
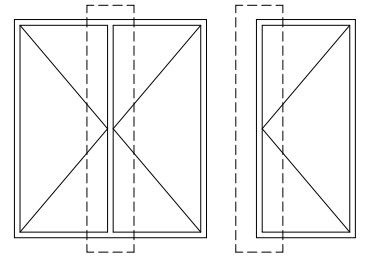
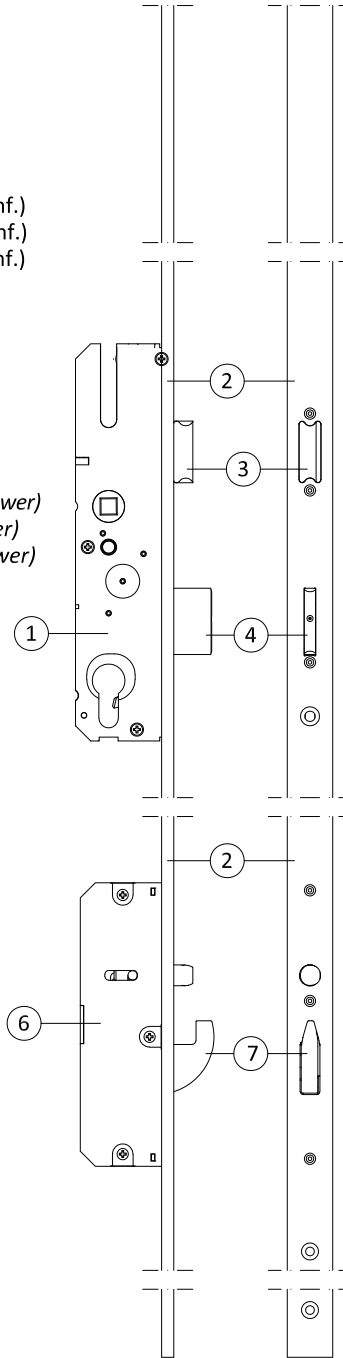

SCHEMA UTILIZZO SERRATURE
DIAGRAM FOR THE USE OF LOCKS

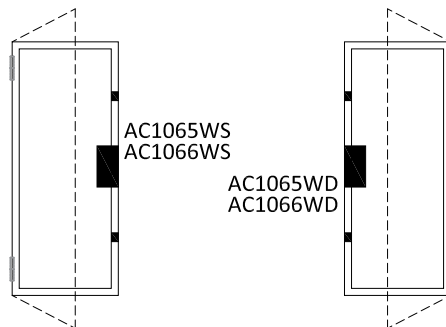

APERTURA INTERNA _ VISTA INTERNA
INWARDS OPENING _ INTERIOR ELEVATION

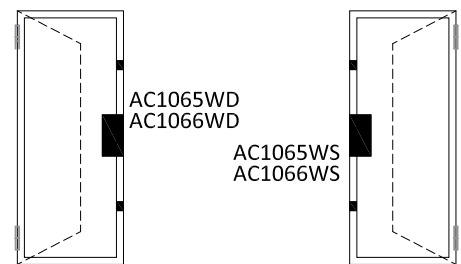

APERTURA ESTERNA _ VISTA INTERNA
OUTWARDS OPENING _ INTERIOR ELEVATION

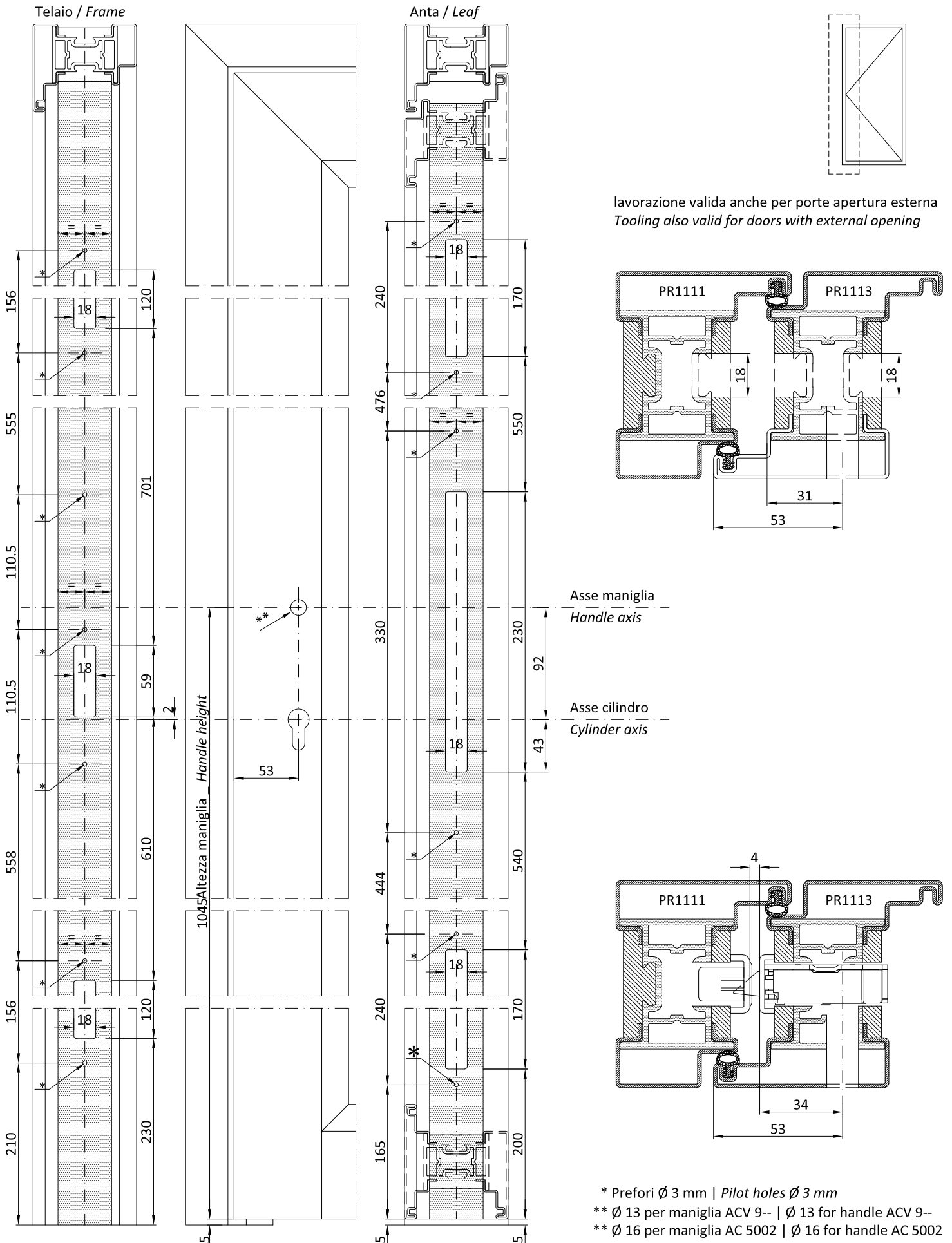

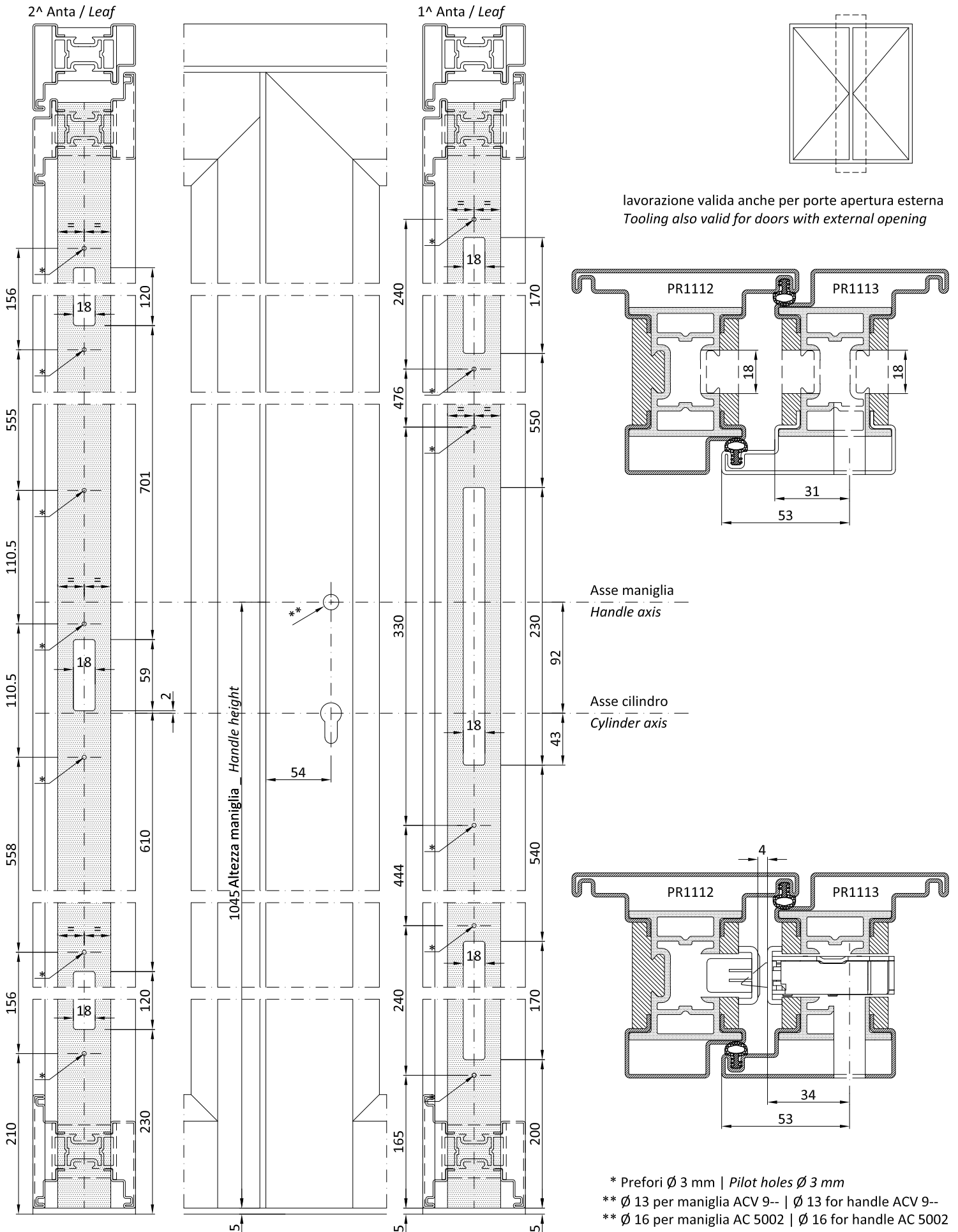

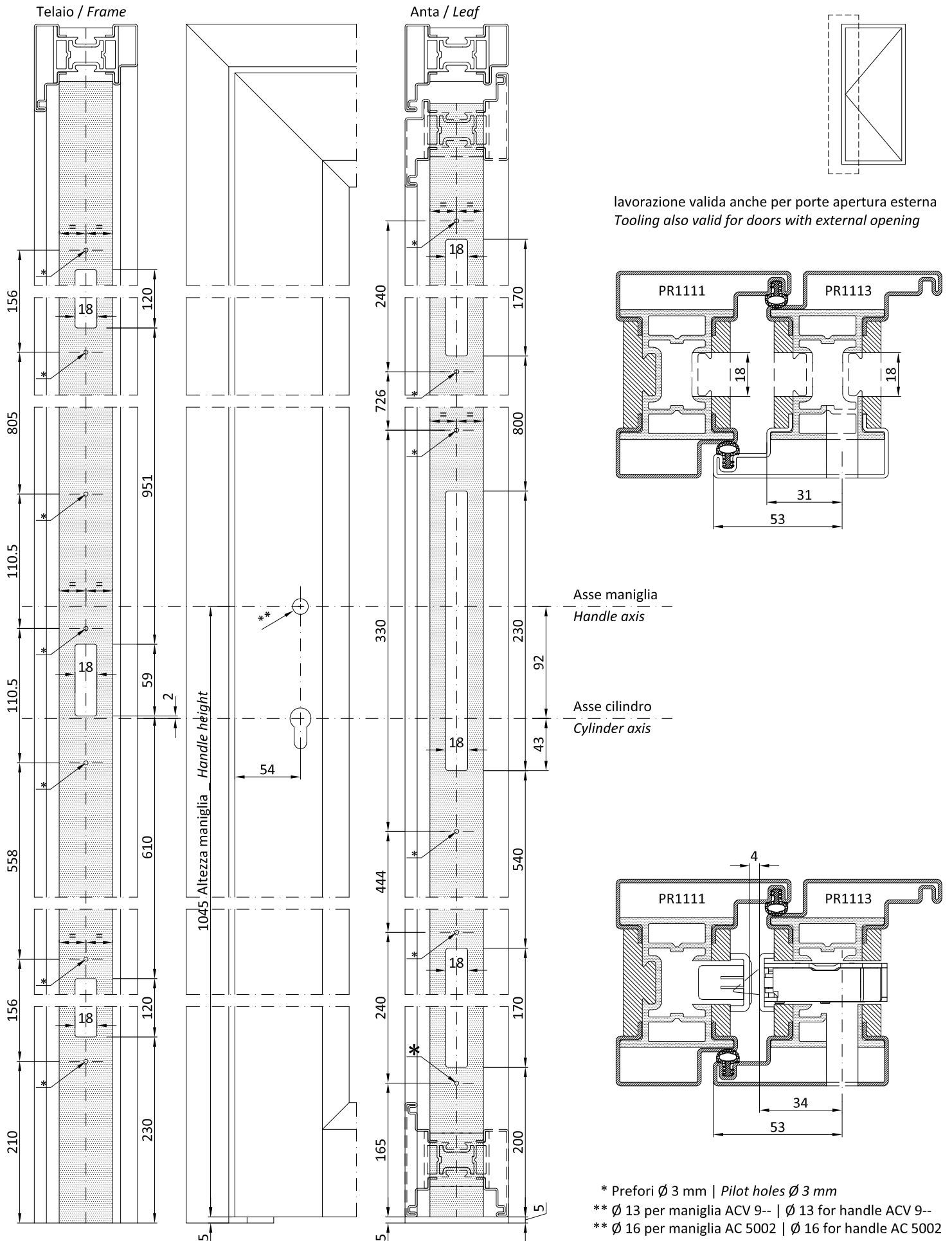

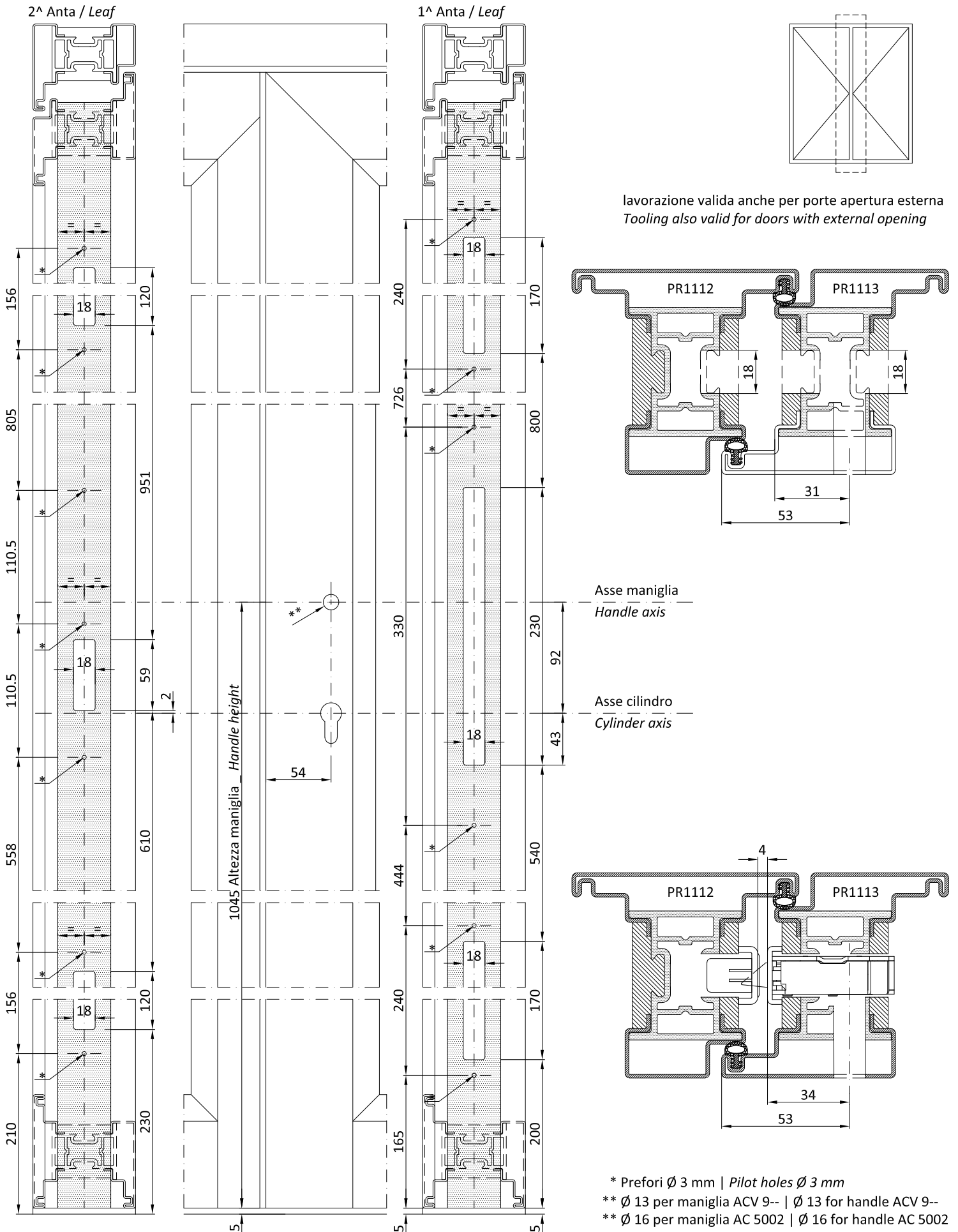

lavorazione valida anche per porte apertura esterna
Tooling also valid for doors with external opening

Asse maniglia
Handle axis

Asse cilindro
Cylinder axis

- * Prefori Ø 3 mm | Pilot holes Ø 3 mm
- ** Ø 13 per maniglia ACV 9-- | Ø 13 for handle ACV 9--
- ** Ø 16 per maniglia AC 5002 | Ø 16 for handle AC 5002

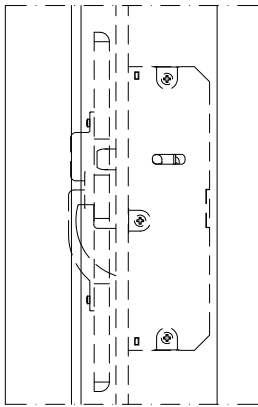

AC1067WD/S

- 1) Serratura
- 2) Frontalino
- 3) Scrocco
- 4) Catenaccio
- 5) Incontro per serratura
- 6) Deviatori (n°3 pezzi sup + inf.)
- 7) Catenaccio (n°3 pezzi sup + inf.)
- 8) Incontro (n°3 pezzi sup + inf.)

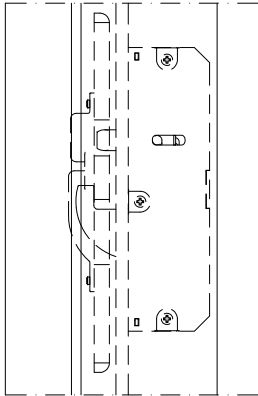
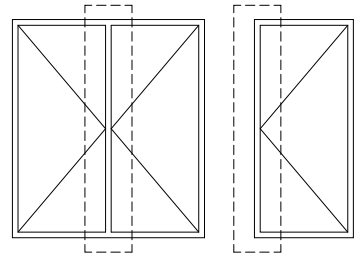

AC1067WD/S

- 1) Lock
- 2) Front plate
- 3) Spring latch
- 4) Bolt
- 5) Strike plate
- 6) Diverters (n° 3 items upper + lower)
- 7) Bolt (n° 3 items upper + lower)
- 8) Plate (n° 3 items upper + lower)

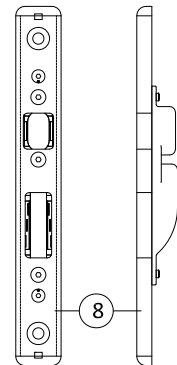
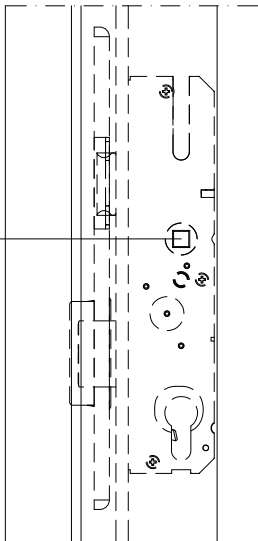
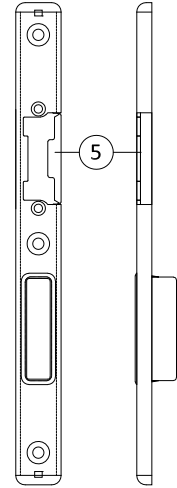
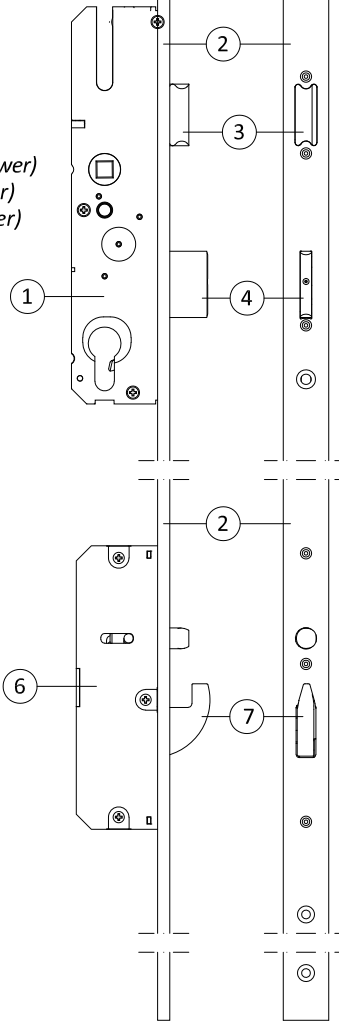

1050

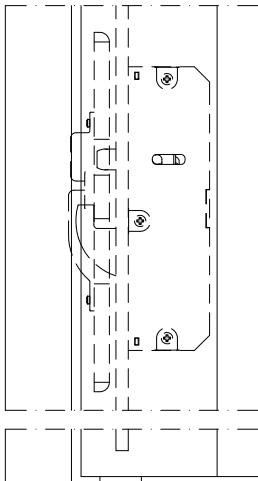

SCHEMA UTILIZZO SERRATURE
DIAGRAM FOR THE USE OF LOCKS

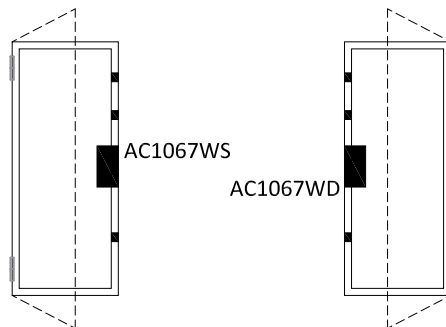

APERTURA INTERNA _ VISTA INTERNA
INWARDS OPENING _ INTERIOR ELEVATION

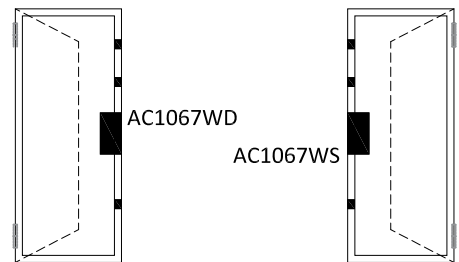

APERTURA ESTERNA _ VISTA INTERNA
OUTWARDS OPENING _ INTERIOR ELEVATION

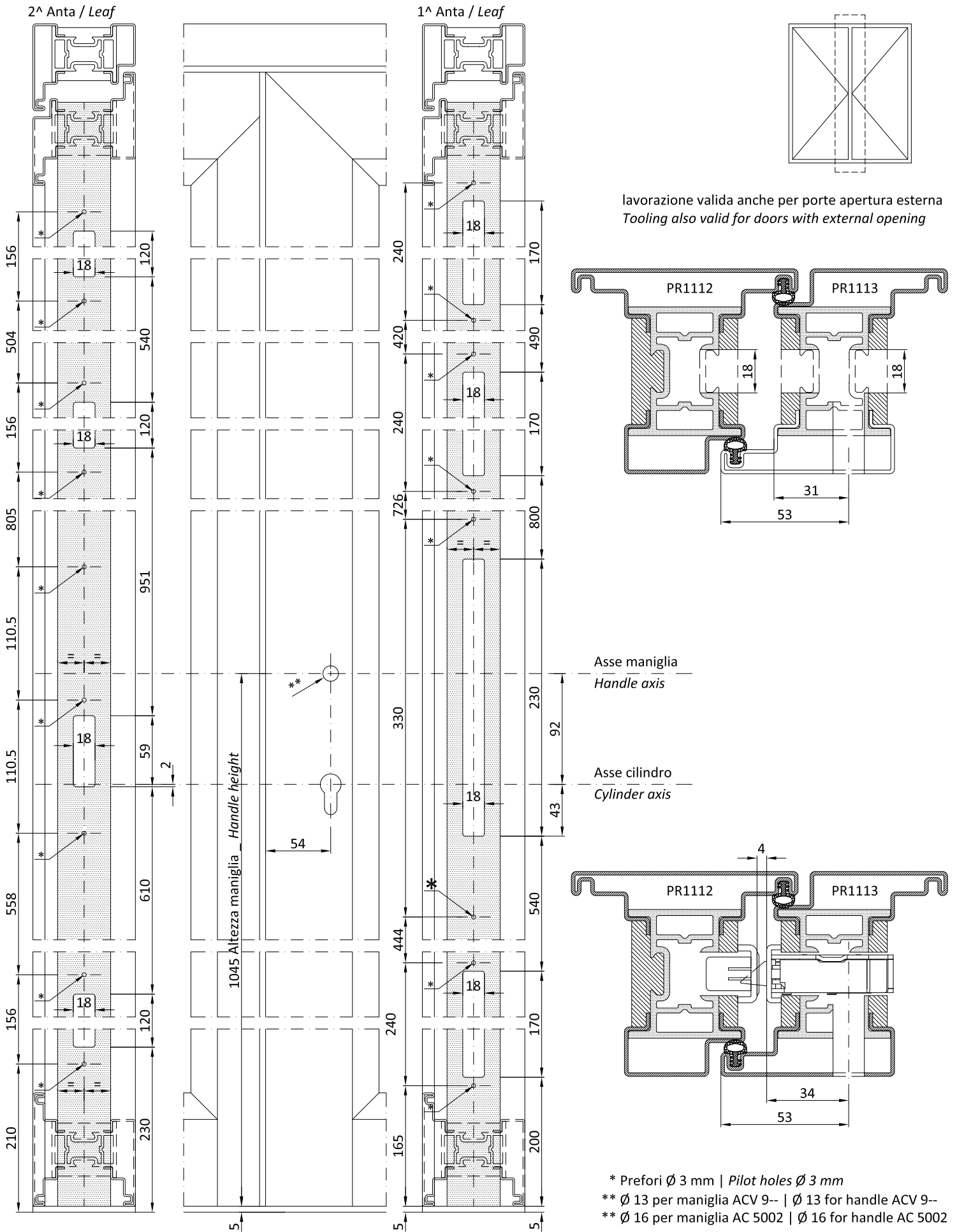

lavorazione valida anche per porte apertura esterna
Tooling also valid for doors with external opening

Asse maniglia
Handle axis

Asse cilindro
Cylinder axis

- * Prefori Ø 3 mm | Pilot holes Ø 3 mm
- ** Ø 13 per maniglia ACV 9-- | Ø 13 for handle ACV 9--
- ** Ø 16 per maniglia AC 5002 | Ø 16 for handle AC 5002

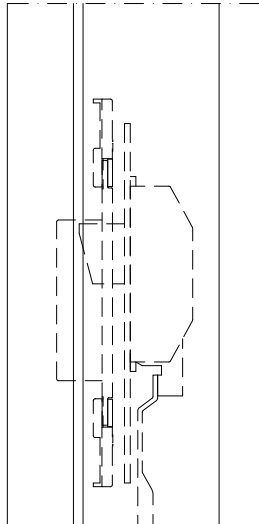

AC1070

- 1) Serratura
- 2) Frontalino
- 3) Riduttore di collegamento
- 4) Scrocco
- 5) Catenaccio
- 6) Incontro per serratura
- 7) Vite inox TS M5x50
- 8) Perno fissaggio asta

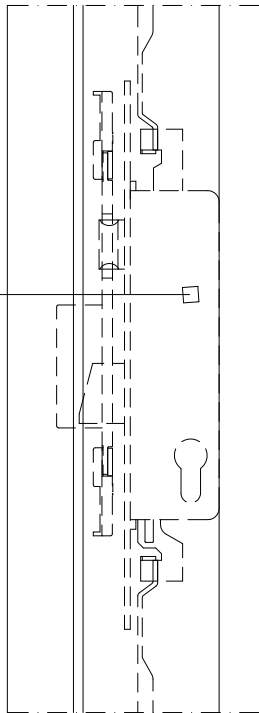
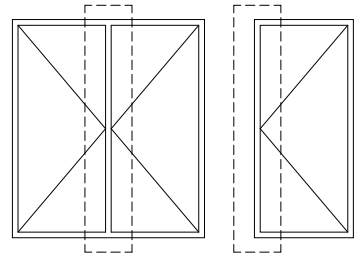

AC1075

- 9) Deviatori (n°2 pezzi sup + inf.)
- 10) Frontalino (n°2 pezzi sup + inf.)
- 11) Catenaccio (n°2 pezzi sup + inf.)
- 12) Aste inox (n°2 pezzi sup + inf.)
- 13) Incontro (n°2 pezzi sup + inf.)

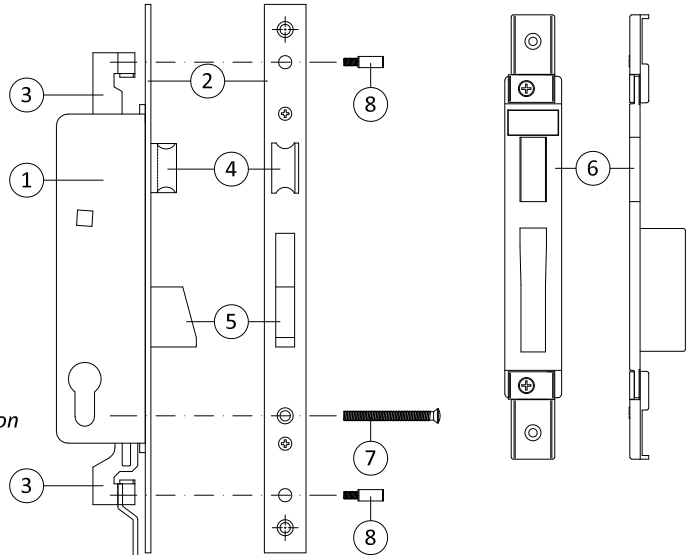

AC1070

- 1) Lock
- 2) Front plate
- 3) Reduction unit/adaptor for connection
- 4) Spring latch
- 5) Bolt
- 6) Strike plate
- 7) Stainless steel screws TS M5x50
- 8) Pin for anchoring the rod

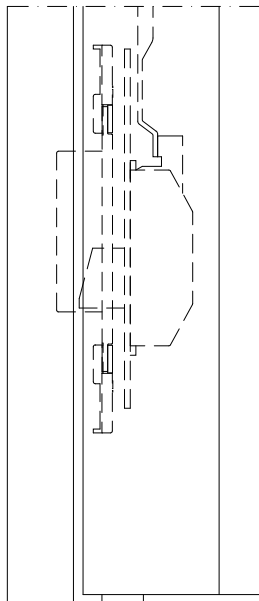

AC1075

- 9) Diverters (n° 2 items upper + lower)
- 10) Apron lining (n° 2 items upper + lower)
- 11) Bolt (n° 2 items upper + lower)
- 12) Stainless steel rods (n° 2 items upper + lower)
- 13) Plate (n° 2 items upper + lower)

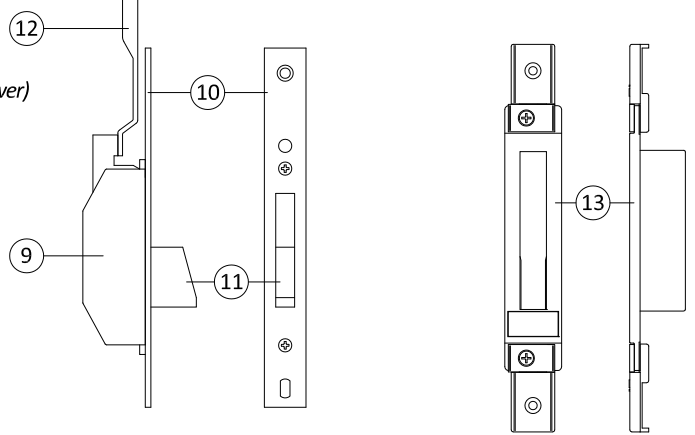

1050

SCHEMA UTILIZZO SERRATURE E TERZE CHIUSURE
DIAGRAM FOR THE USE OF LOCKS AND THIRD LOCKS

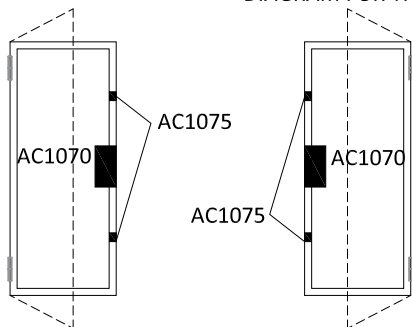

APERTURA INTERNA_ VISTA INTERNA
INWARDS OPENING_ INTERIOR ELEVATION

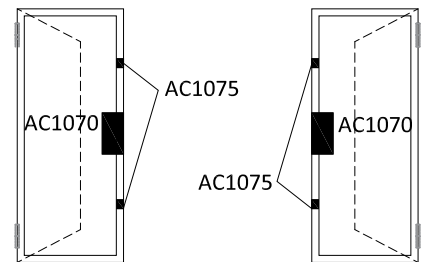

APERTURA ESTERNA_ VISTA INTERNA
OUTWARDS OPENING_ INTERIOR ELEVATION

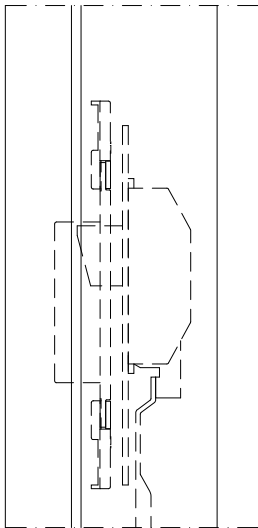

AC1071

- 1) Serratura
- 2) Frontalino
- 3) Riduttore di collegamento
- 4) Rullo
- 5) Catenaccio
- 6) Incontro per serratura
- 7) Vaschetta per rullo
- 8) Vite inox TS M5x50
- 9) Perno fissaggio asta

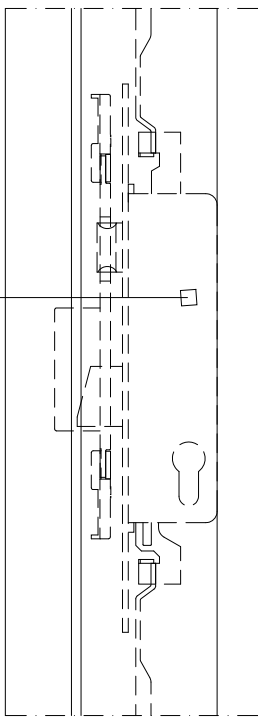
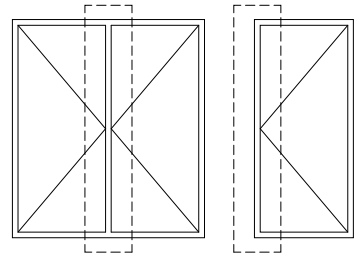

AC1075

- 10) Deviatori (n°2 pezzi sup + inf.)
- 11) Frontalino (n°2 pezzi sup + inf.)
- 12) Catenaccio (n°2 pezzi sup + inf.)
- 13) Aste inox (n°2 pezzi sup + inf.)
- 14) Incontro (n°2 pezzi sup + inf.)

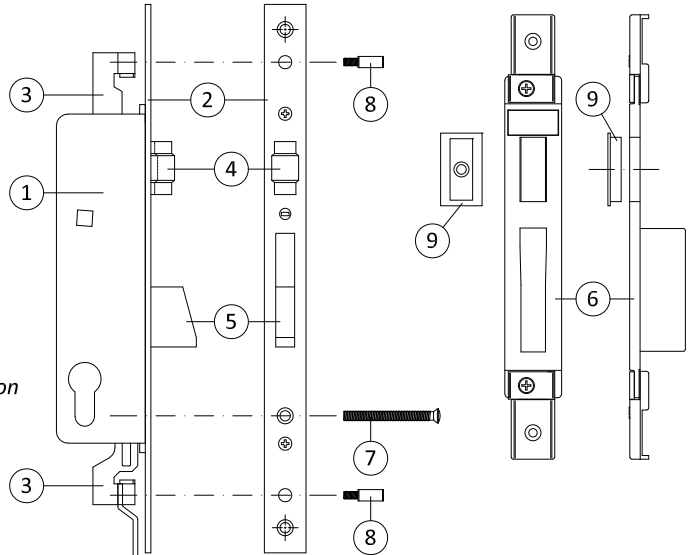

AC1071

- 1) Lock
- 2) Front plate
- 3) Reduction unit/adapters for connection
- 4) Roller
- 5) Bolt
- 6) Strike plate
- 7) Compartment for roller
- 8) Stainless steel screws TS M5x50
- 9) Pin for anchoring the rod

AC1075

- 10) Diverters (n° 2 items upper + lower)
- 11) Apron lining (n° 2 items upper + lower)
- 11) Bolt (n° 2 items upper + lower)
- 13) Stainless steel rods (n° 2 items upper + lower)
- 14) Plate (n° 2 items upper + lower)

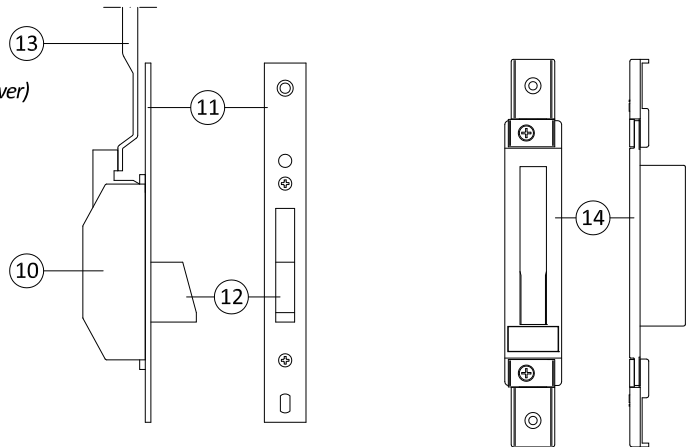

1050

**SCHEMA UTILIZZO SERRATURE E TERZE CHIUSURE
DIAGRAM FOR THE USE OF LOCKS AND THIRD LOCKS**

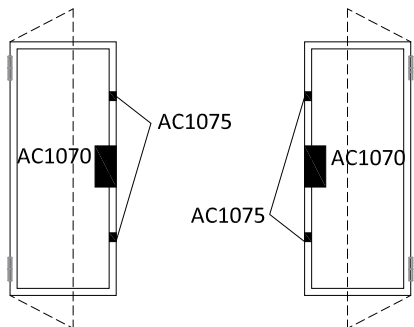

APERTURA INTERNA _ VISTA INTERNA
INWARDS OPENING _ INTERIOR ELEVATION

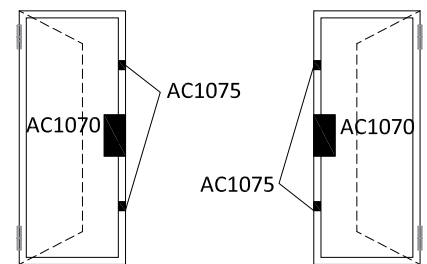

APERTURA ESTERNA _ VISTA INTERNA
OUTWARDS OPENING _ INTERIOR ELEVATION

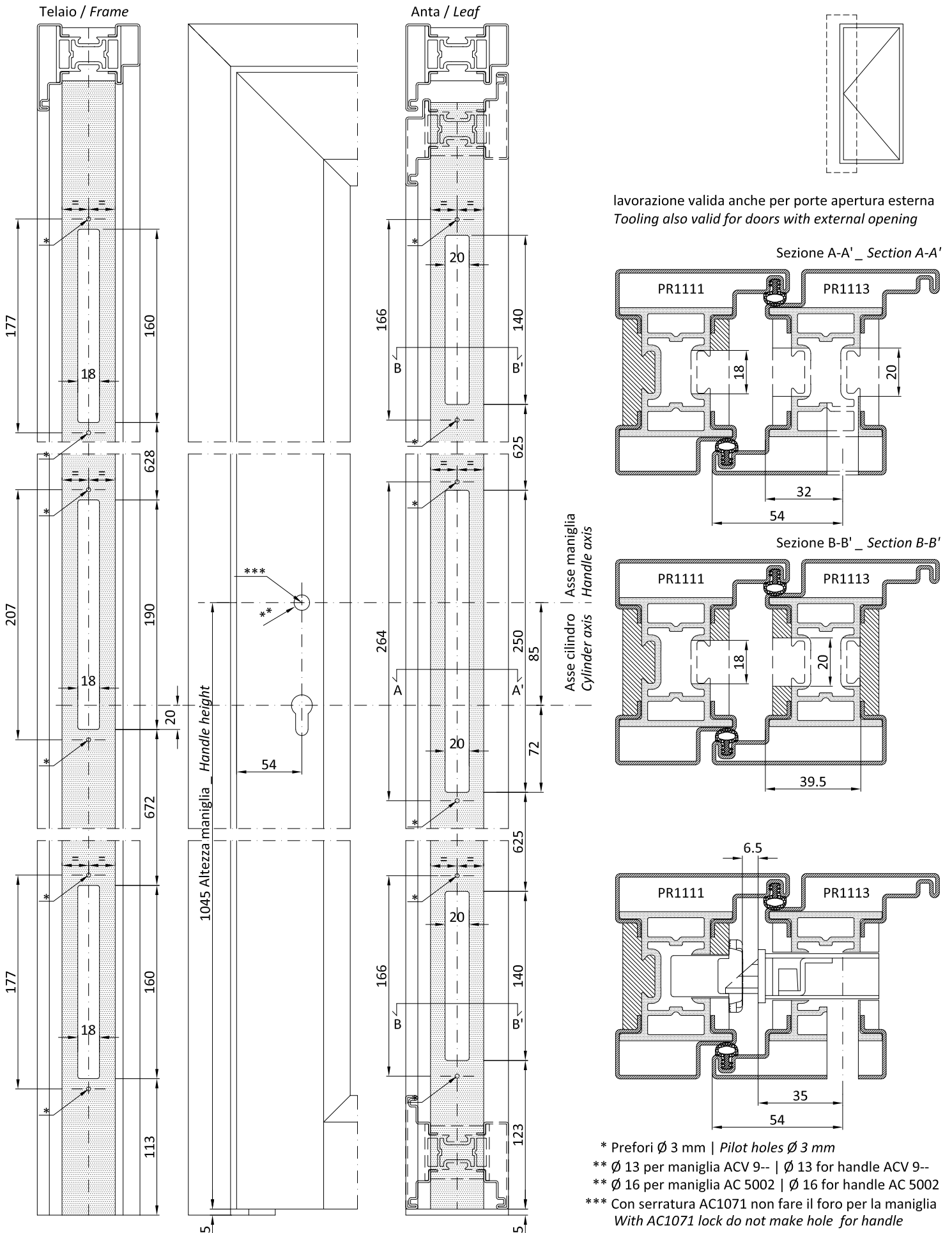

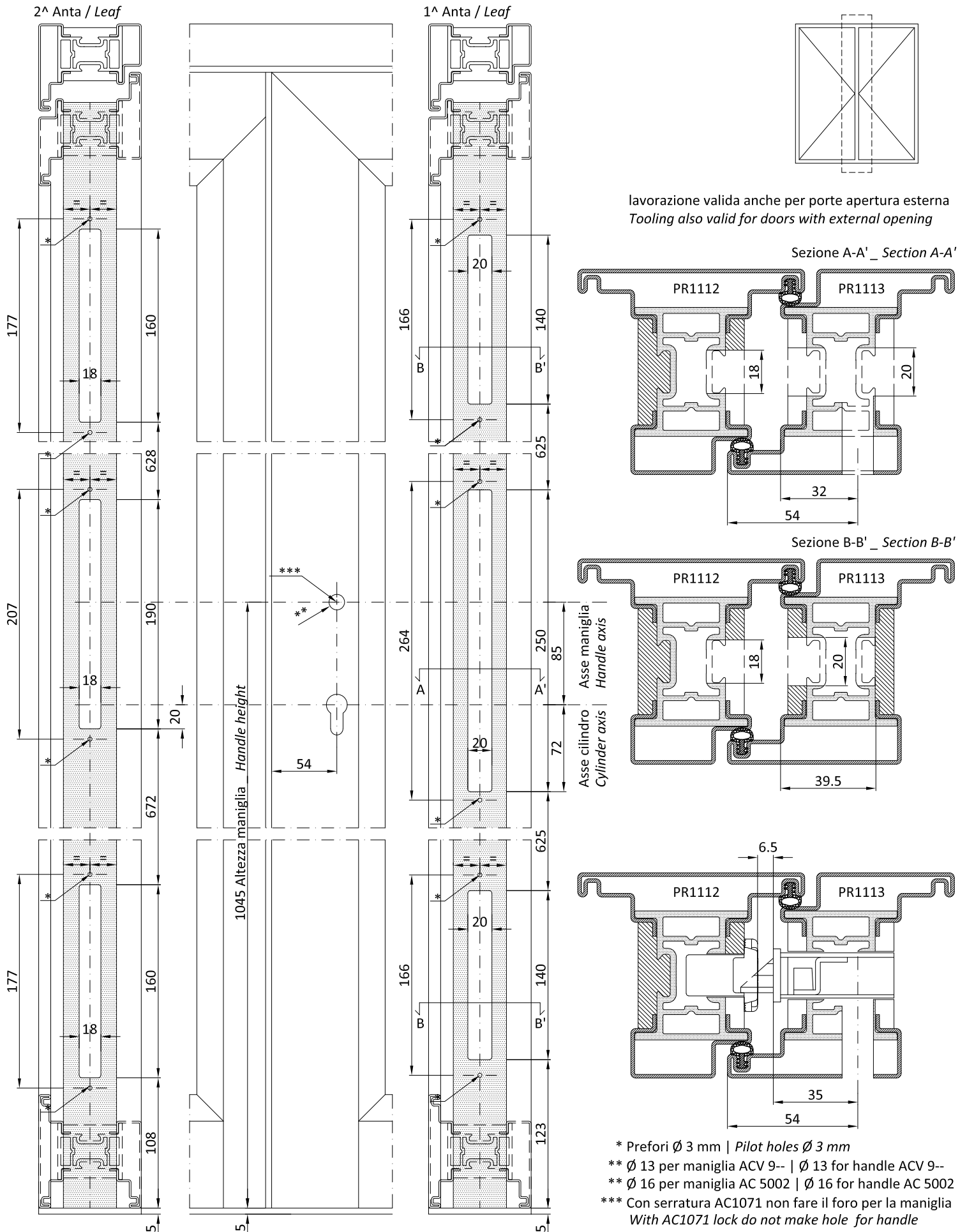

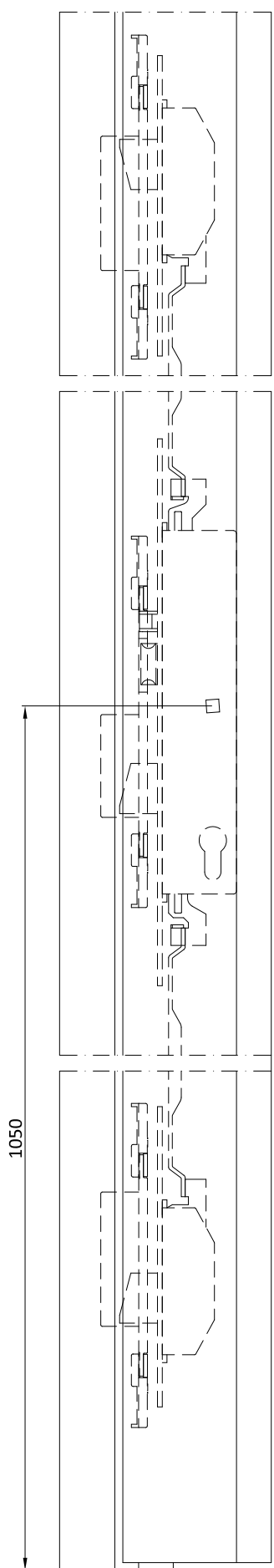

AC1072

- 1) Serratura
- 2) Frontalino
- 3) Riduttore di collegamento
- 4) Scrocco
- 5) Catenaccio
- 6) Incontro per serratura
- 7) Vite inox TS M5x50
- 8) Perno fissaggio asta

AC1075

- 9) Deviatori (n°2 pezzi sup + inf.)
- 10) Frontalino (n°2 pezzi sup + inf.)
- 11) Catenaccio (n°2 pezzi sup + inf.)
- 12) Aste inox (n°2 pezzi sup + inf.)
- 13) Incontro (n°2 pezzi sup + inf.)

AC1072

- 1) Lock
- 2) Front plate
- 3) Reduction unit/adaptor for connection
- 4) Spring latch
- 5) Bolt
- 6) Strike plate
- 7) Stainless steel screws TS M5x50
- 8) Pin for anchoring the rod

AC1075

- 9) Diverters (n° 2 items upper + lower)
- 10) Apron lining (n° 2 items upper + lower)
- 11) Bolt (n° 2 items upper + lower)
- 12) Stainless steel rods (n° 2 items upper + lower)
- 13) Plate (n° 2 items upper + lower)

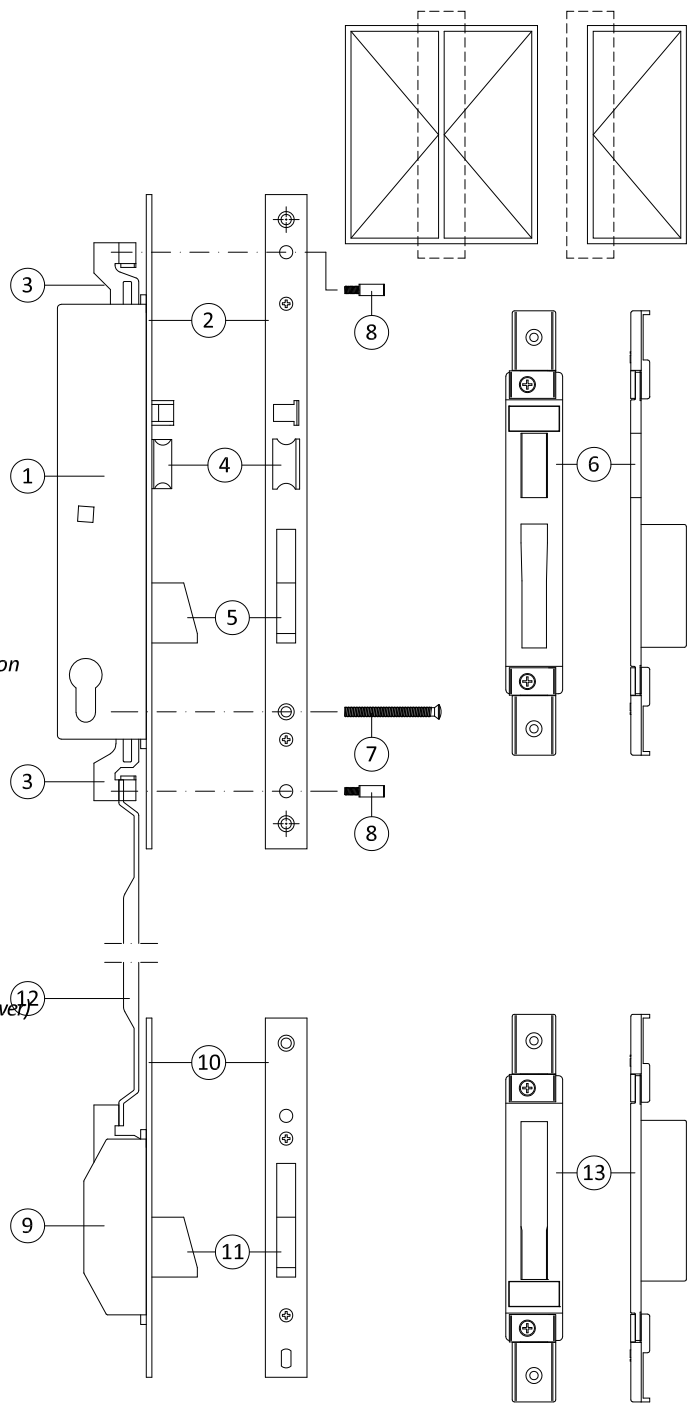

SCHEMA UTILIZZO SERRATURE E TERZE CHIUSURE
DIAGRAM FOR THE USE OF LOCKS AND THIRD LOCKS

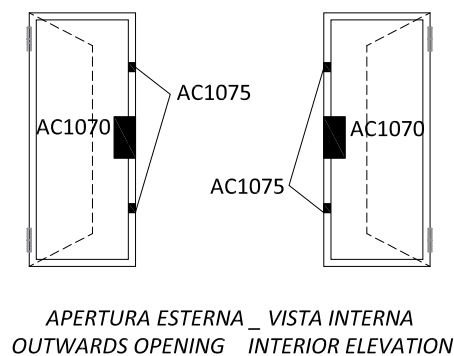
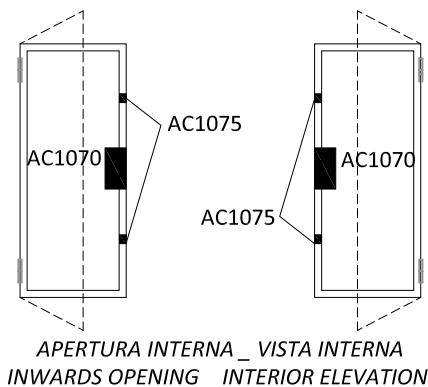

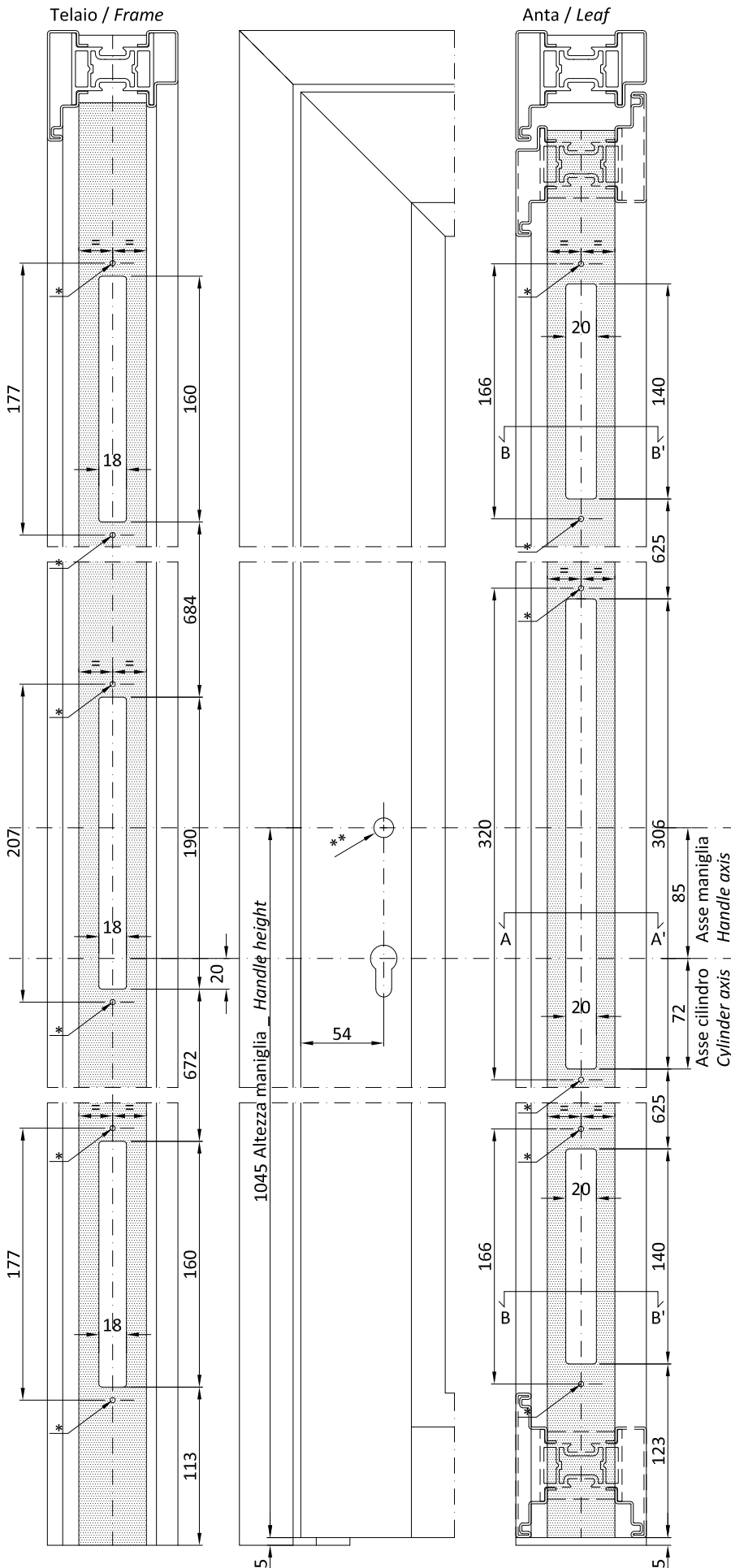

lavorazione valida anche per porte apertura esterna
Tooling also valid for doors with external opening

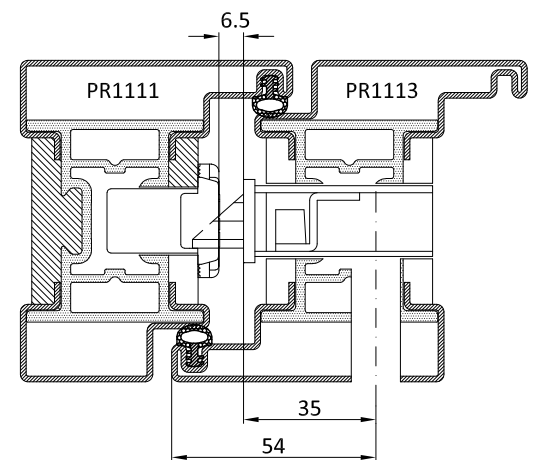
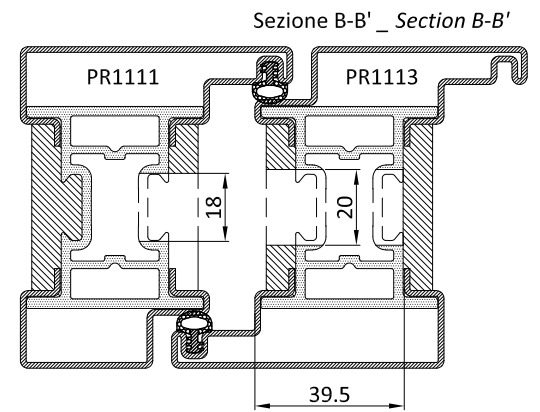
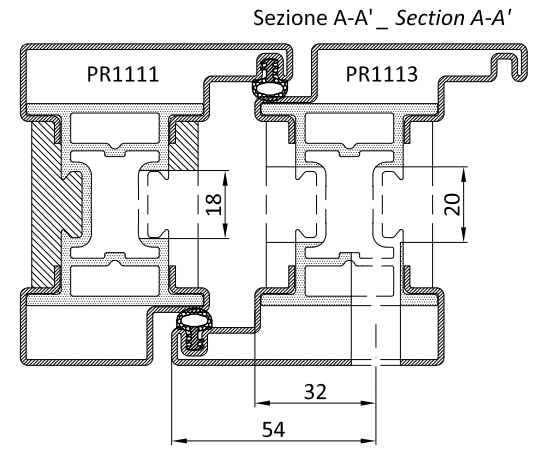

- * Prefori Ø 3 mm | Pilot holes Ø 3 mm
- ** Ø 13 per maniglia ACV 9-- | Ø 13 for handle ACV 9--
- ** Ø 16 per maniglia AC 5002 | Ø 16 for handle AC 5002

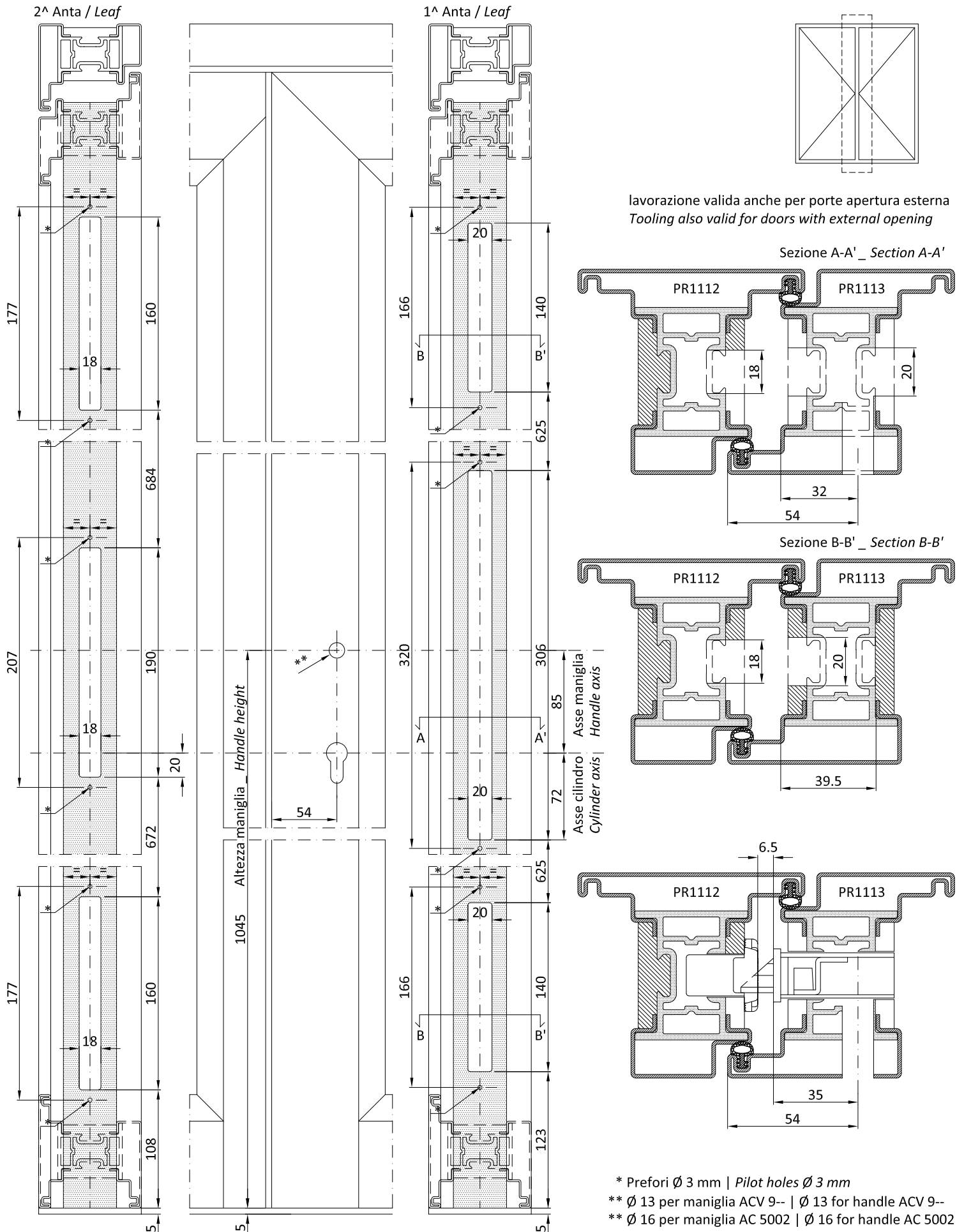

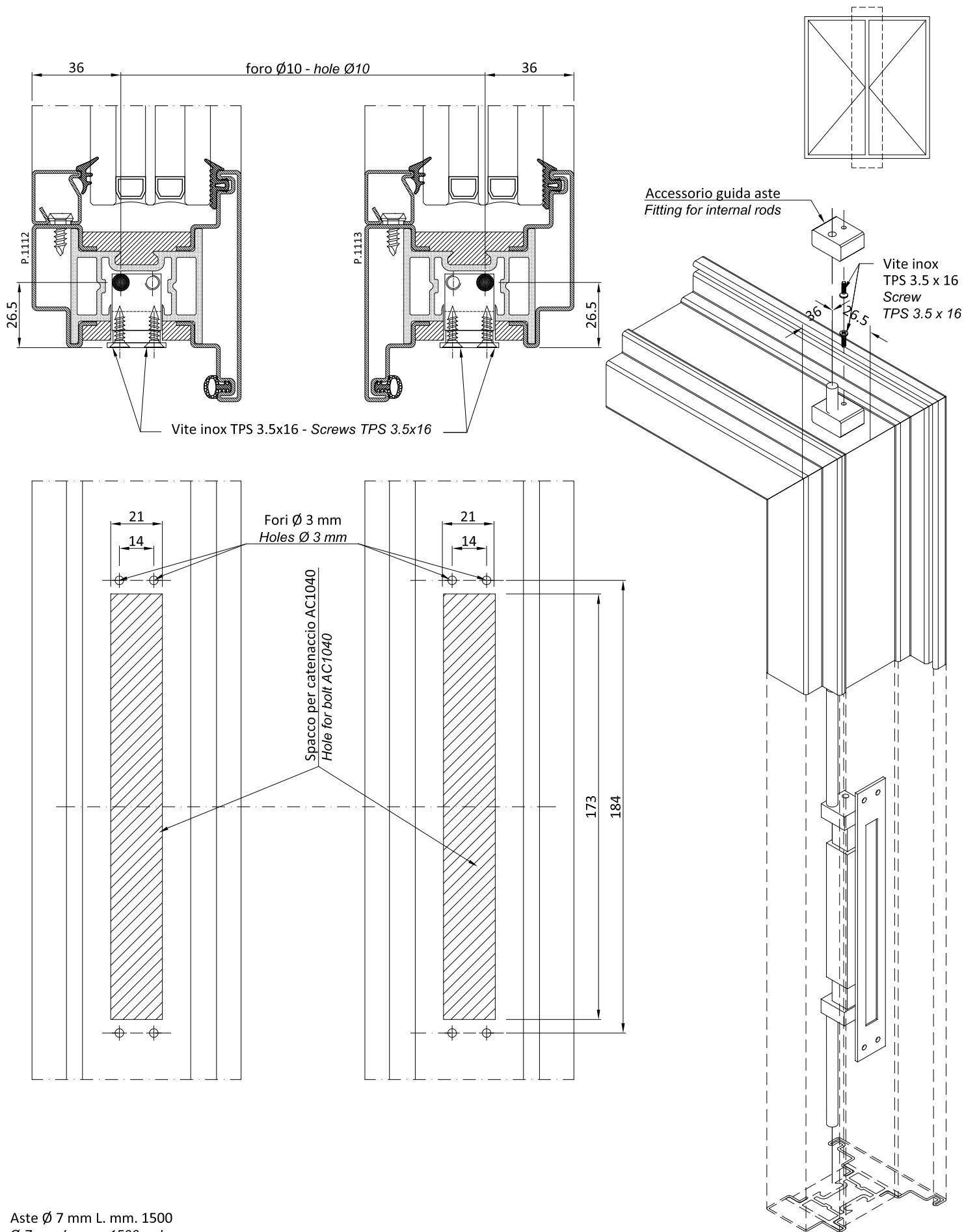

Aste $\varnothing 7$ mm L. mm. 1500
 $\varnothing 7$ mm L. mm. 1500 rods



AC1040 catenaccio
AC1040 bolt

cod.	dimensioni dimensions [mm]
AC1081/A	615 → 730
AC1081/B	715 → 830
AC1081/C	815 → 930
AC1081/D	915 → 1030
AC1081/E	1015 → 1130
AC1081/F	1115 → 1230

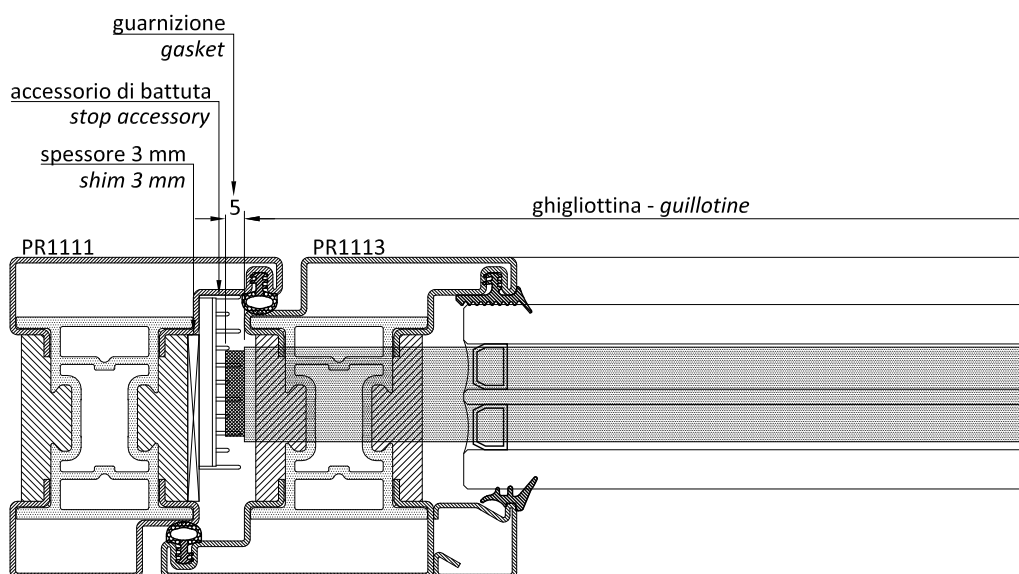
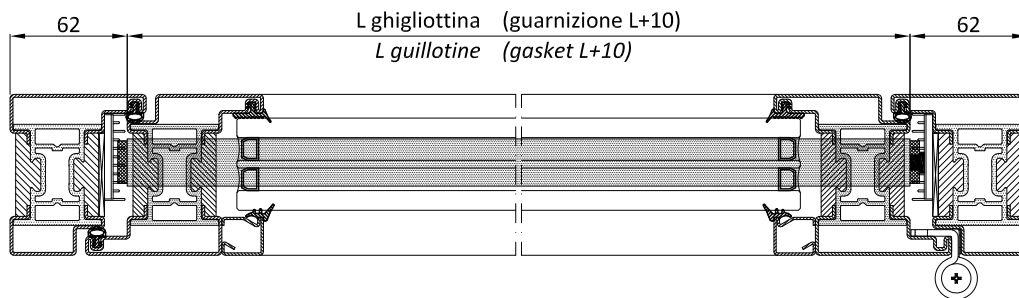
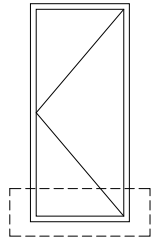

cod.	dimensioni dimensions [mm]
AC1081/A	615 → 730
AC1081/B	715 → 830
AC1081/C	815 → 930
AC1081/D	915 → 1030
AC1081/E	1015 → 1130
AC1081/F	1115 → 1230

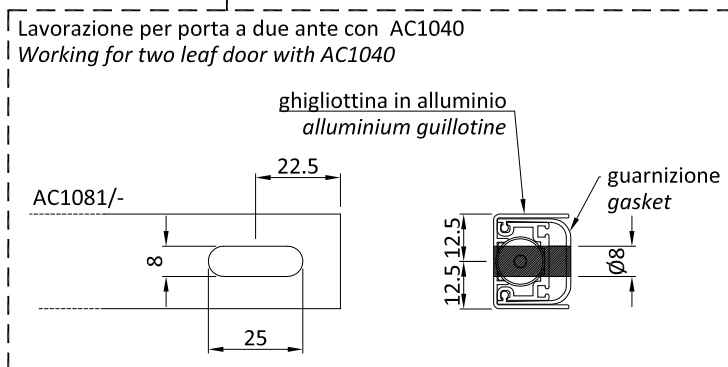
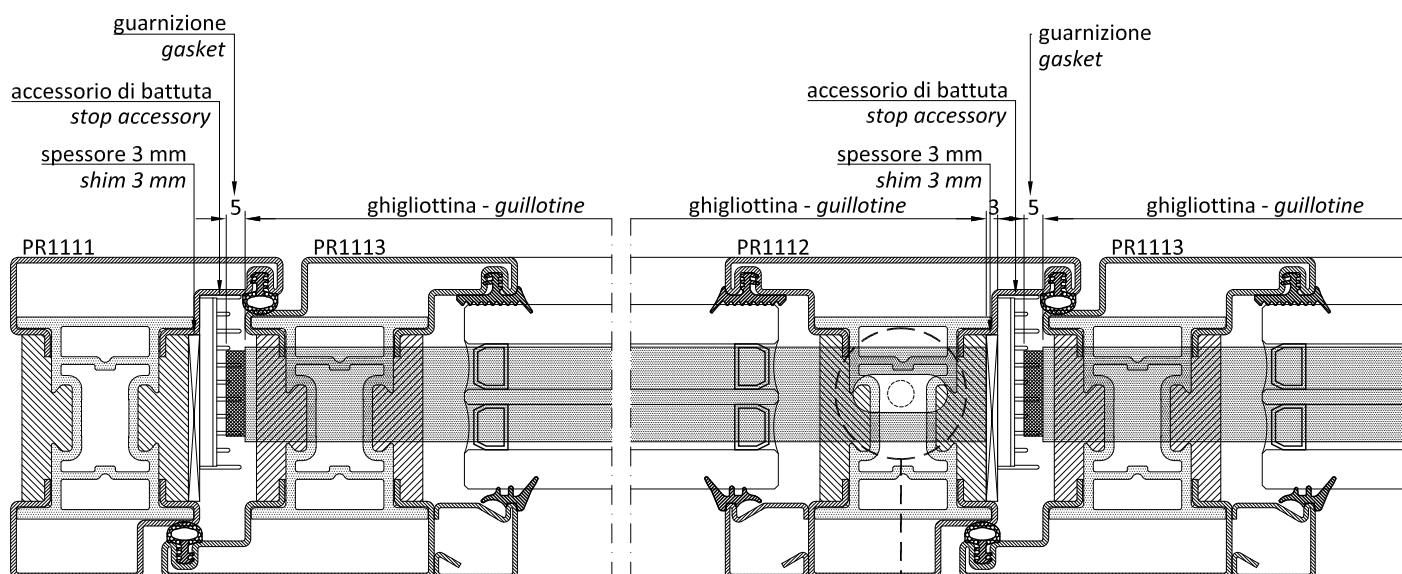
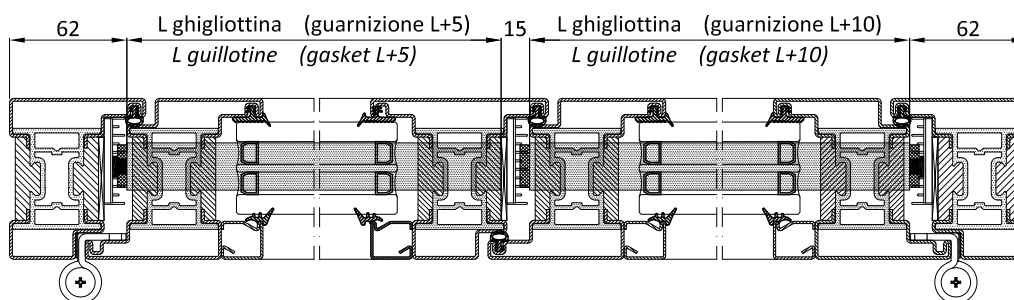
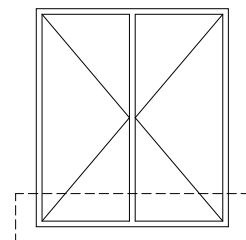

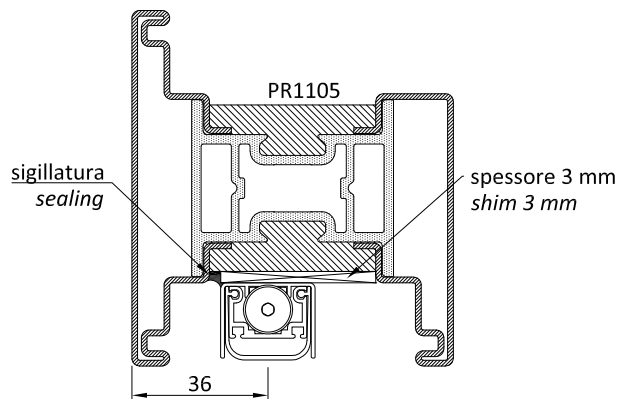
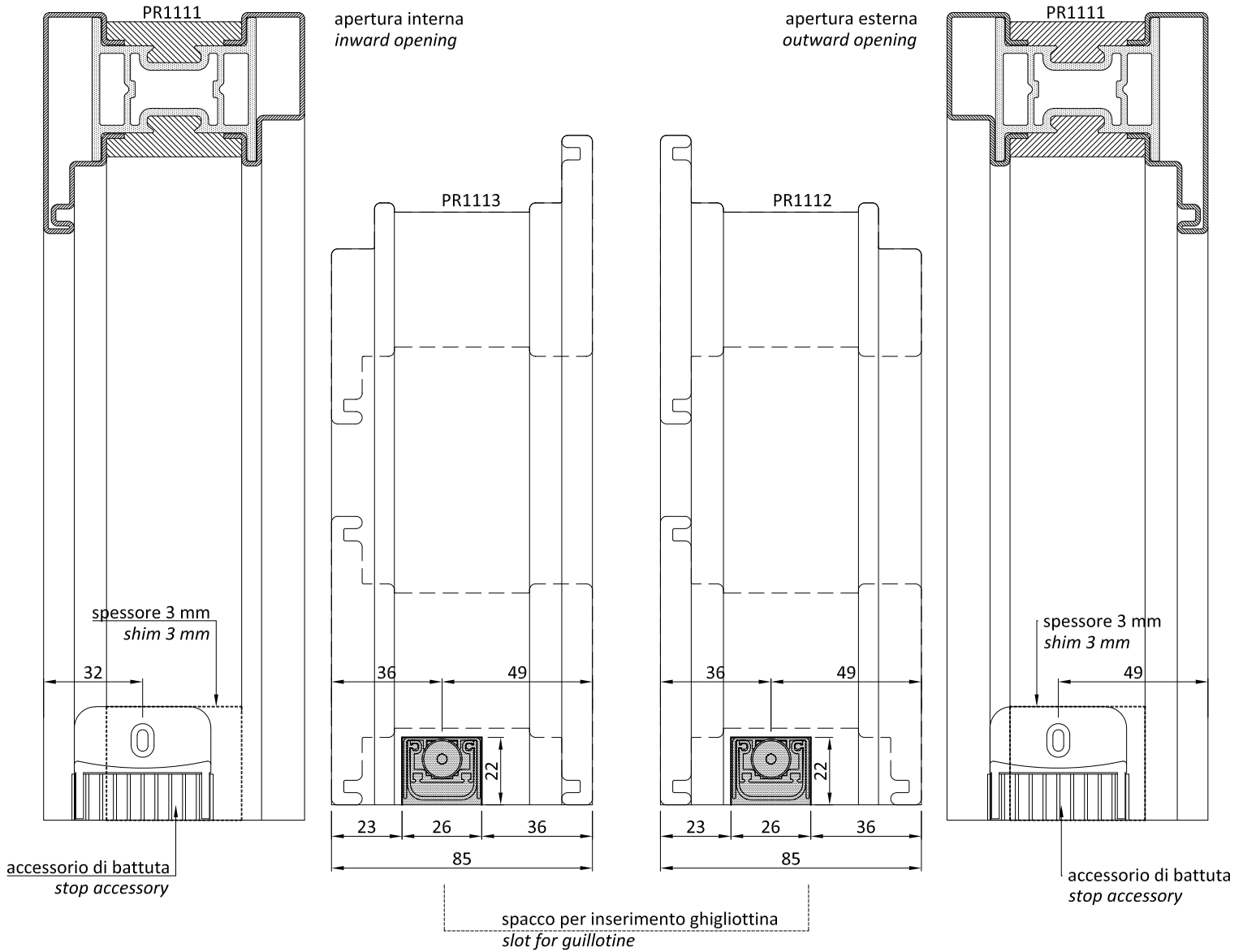
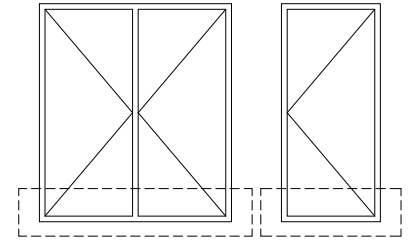

viti in dotazione
supplied screws

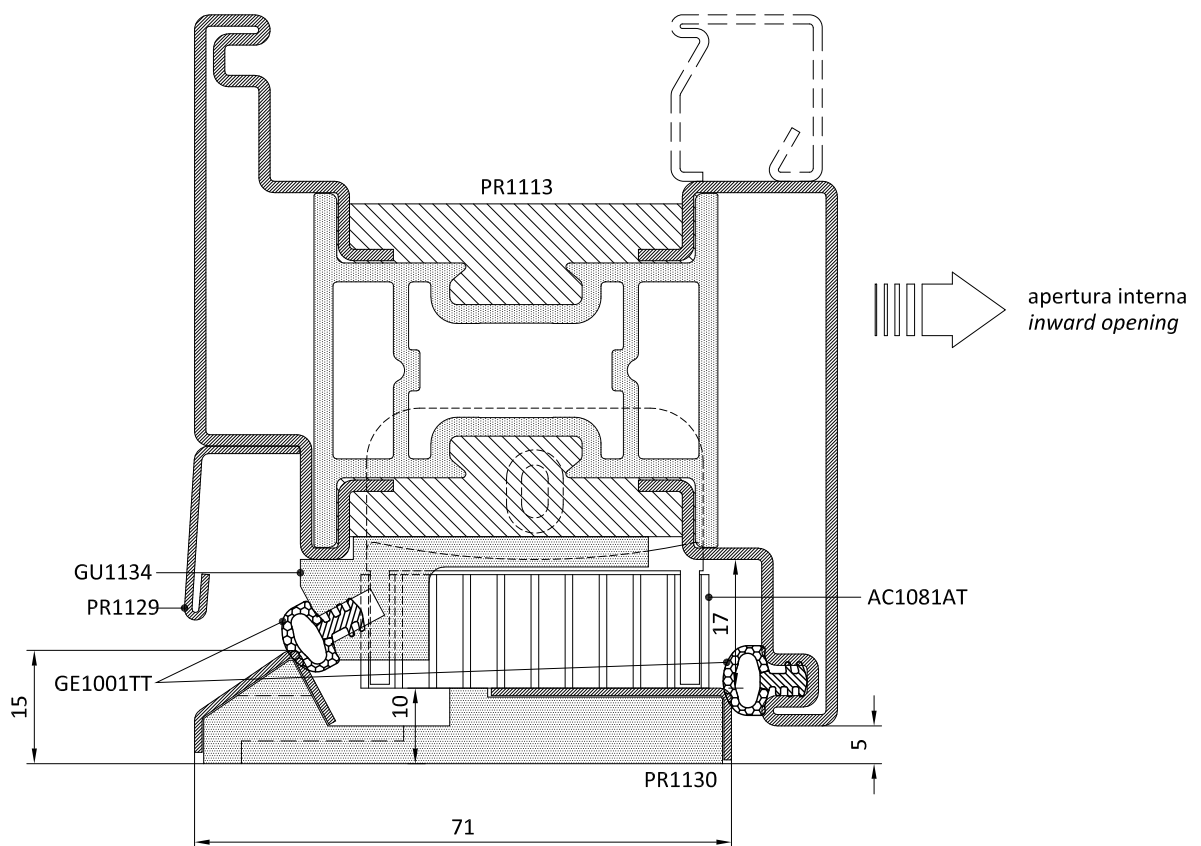
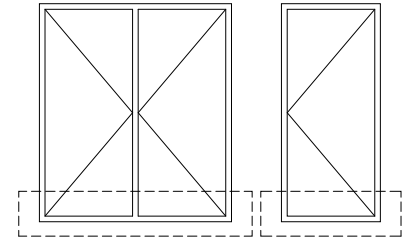

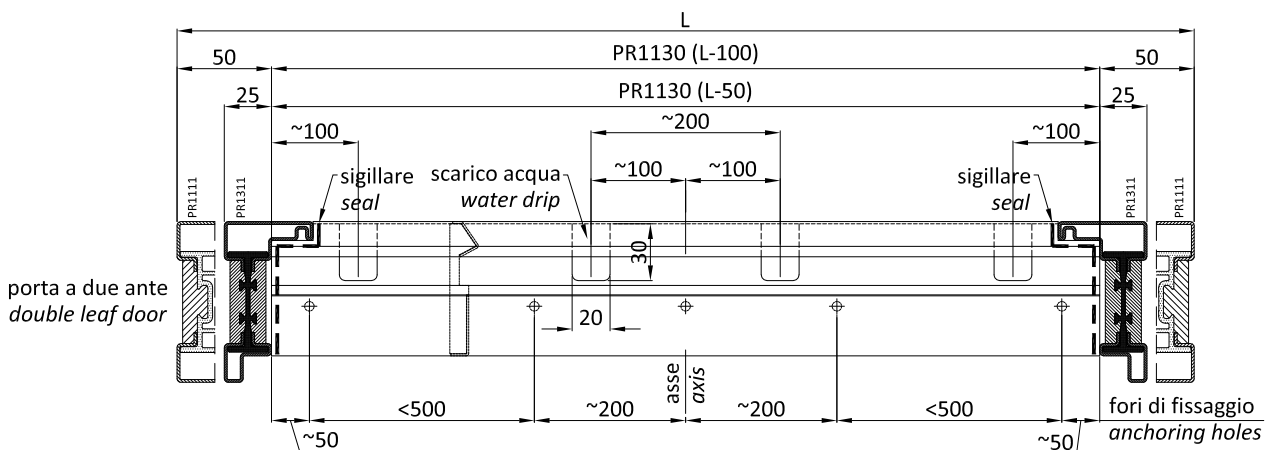
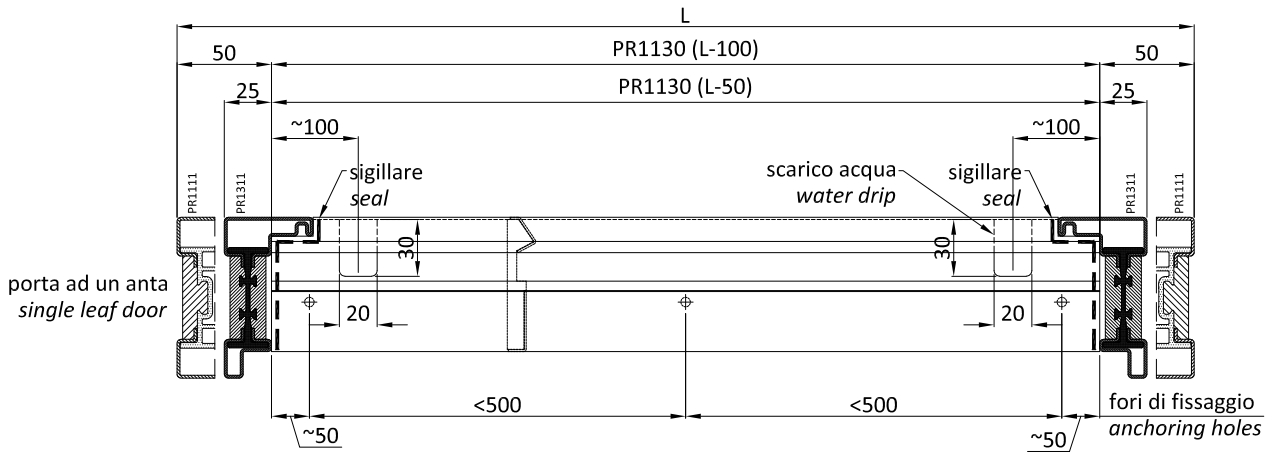
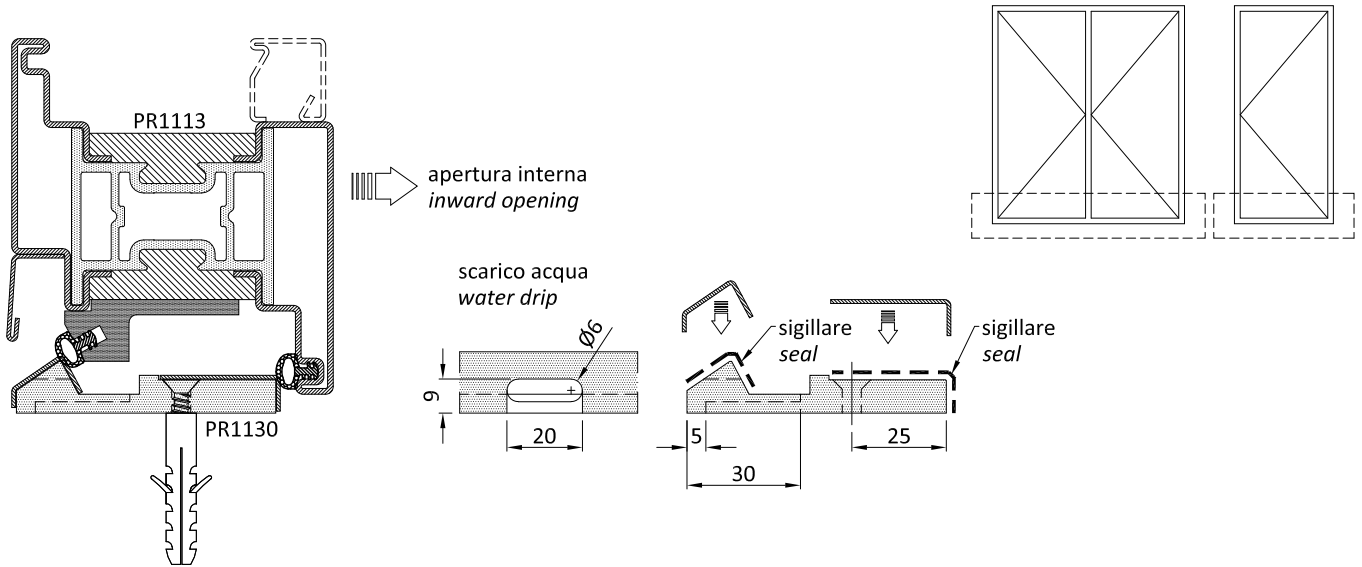

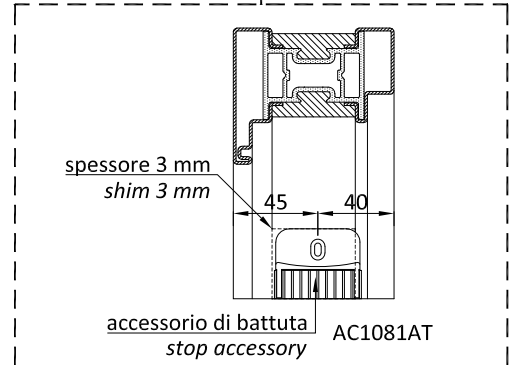
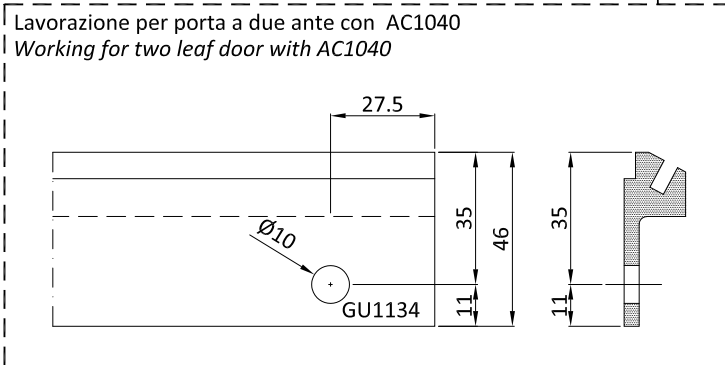
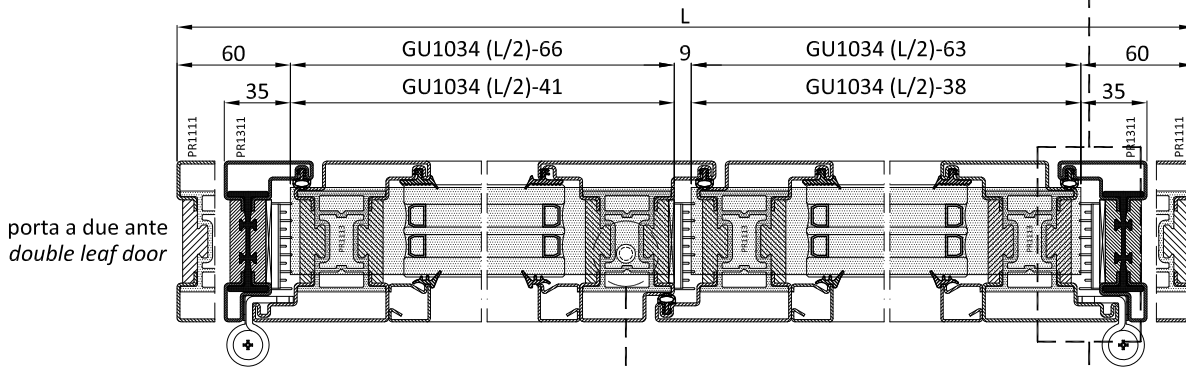
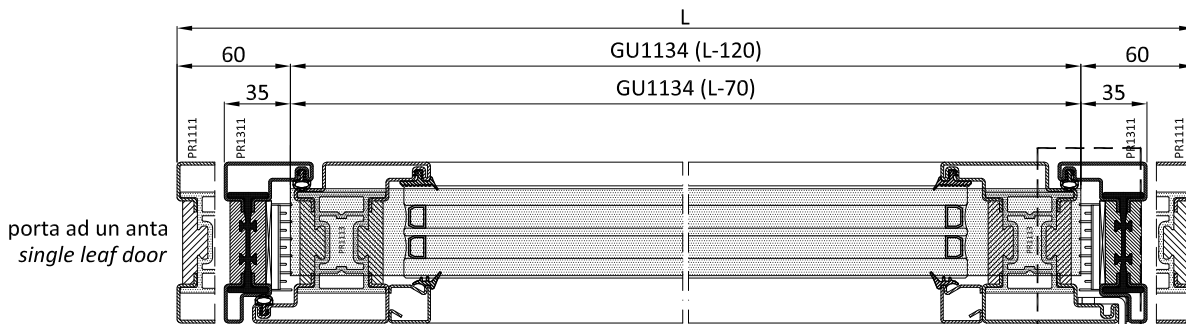
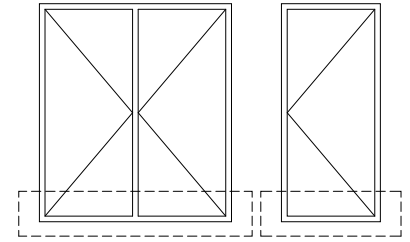
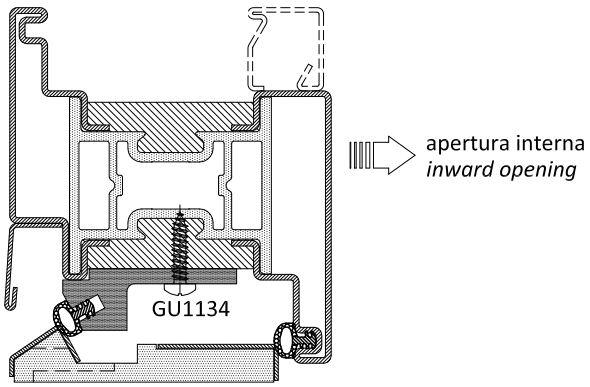

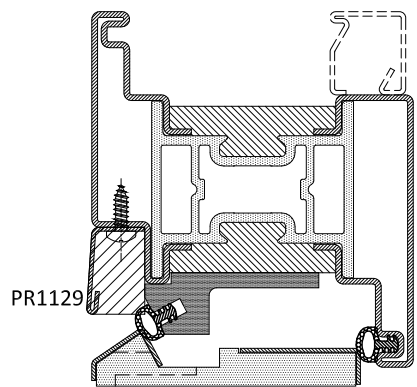

apertura interna
inward opening

tappo di finitura*
ending cap*

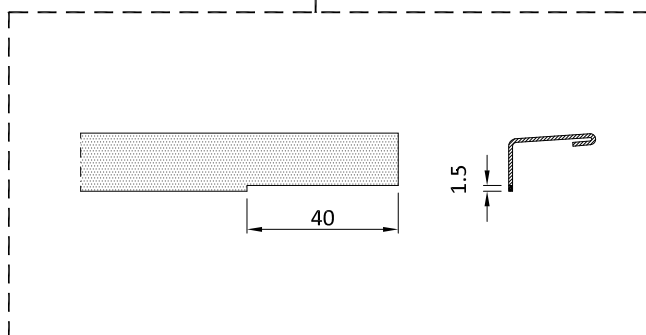
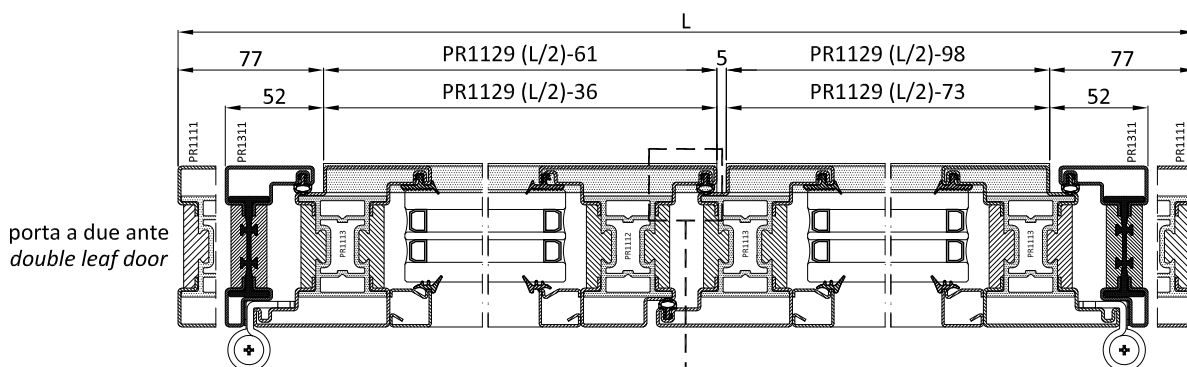
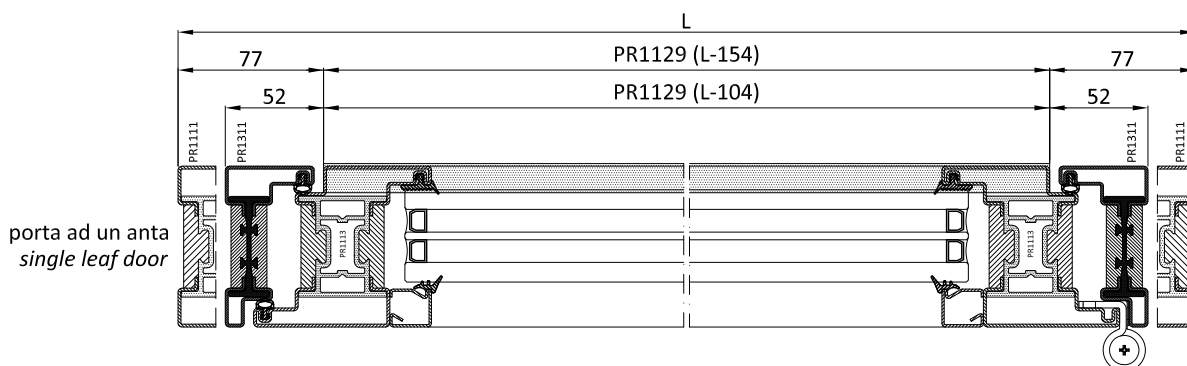
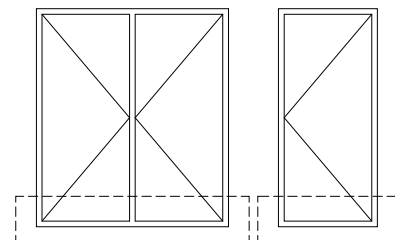
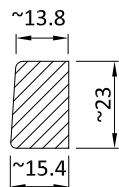

*non forniti
*not included

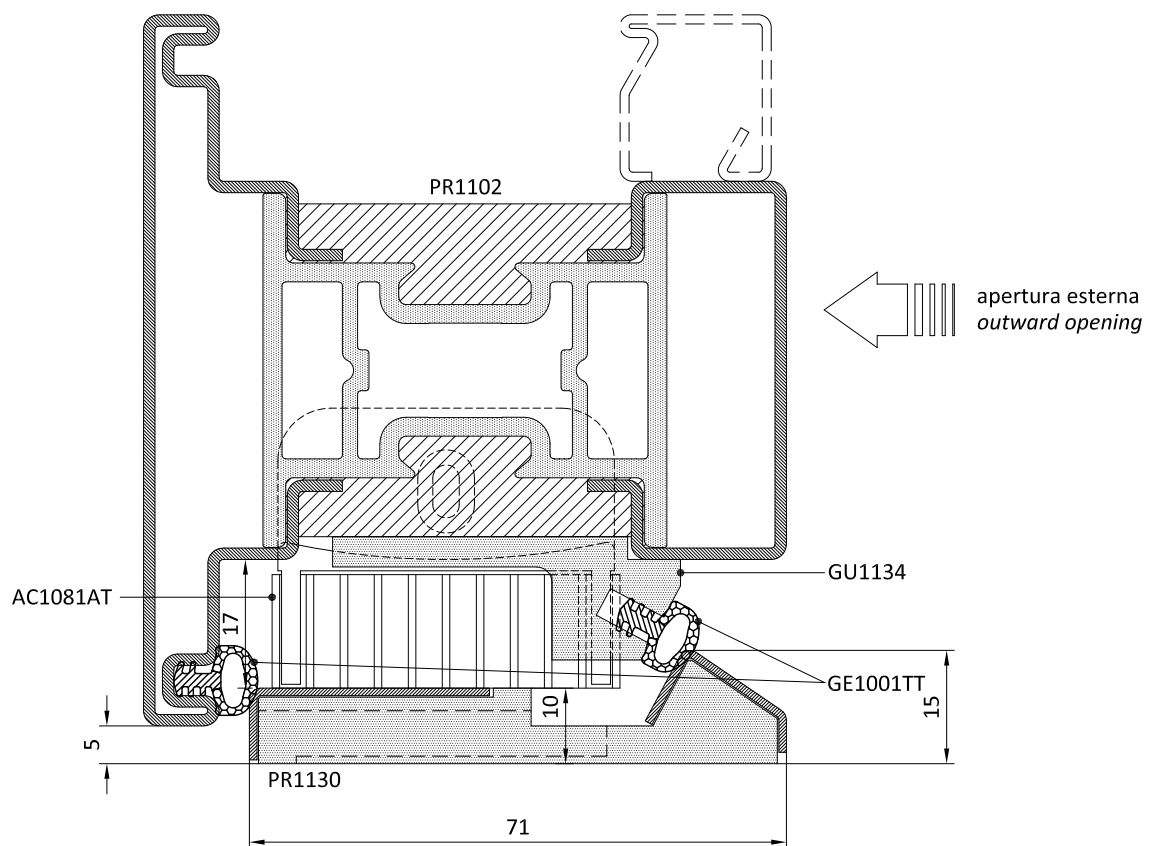
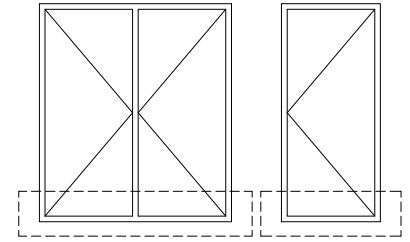

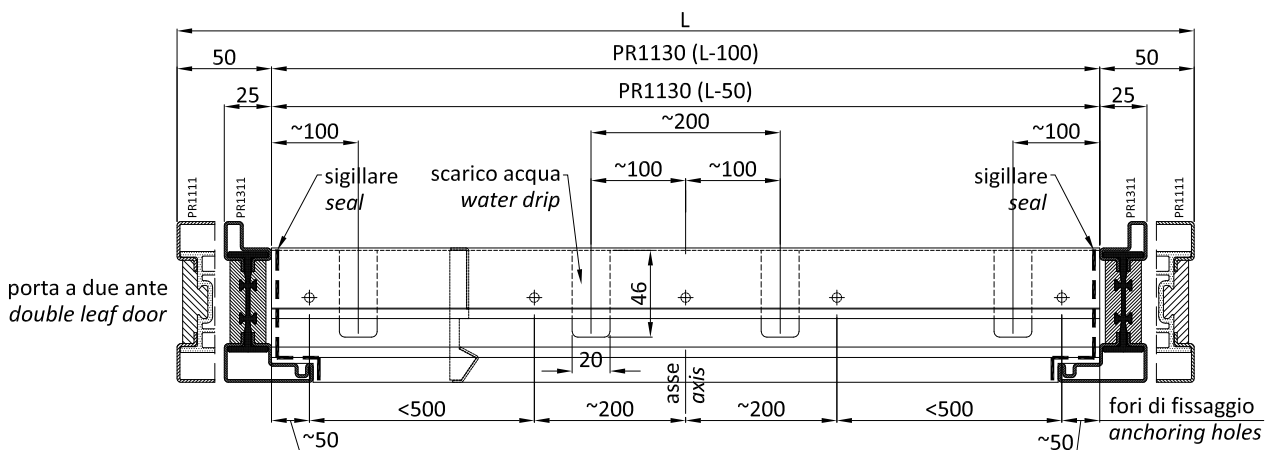
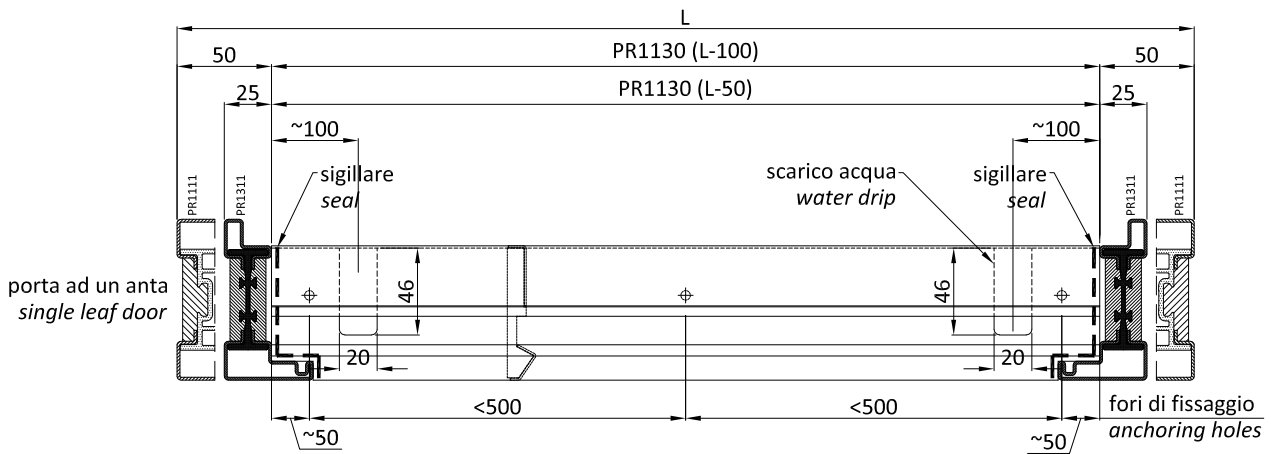
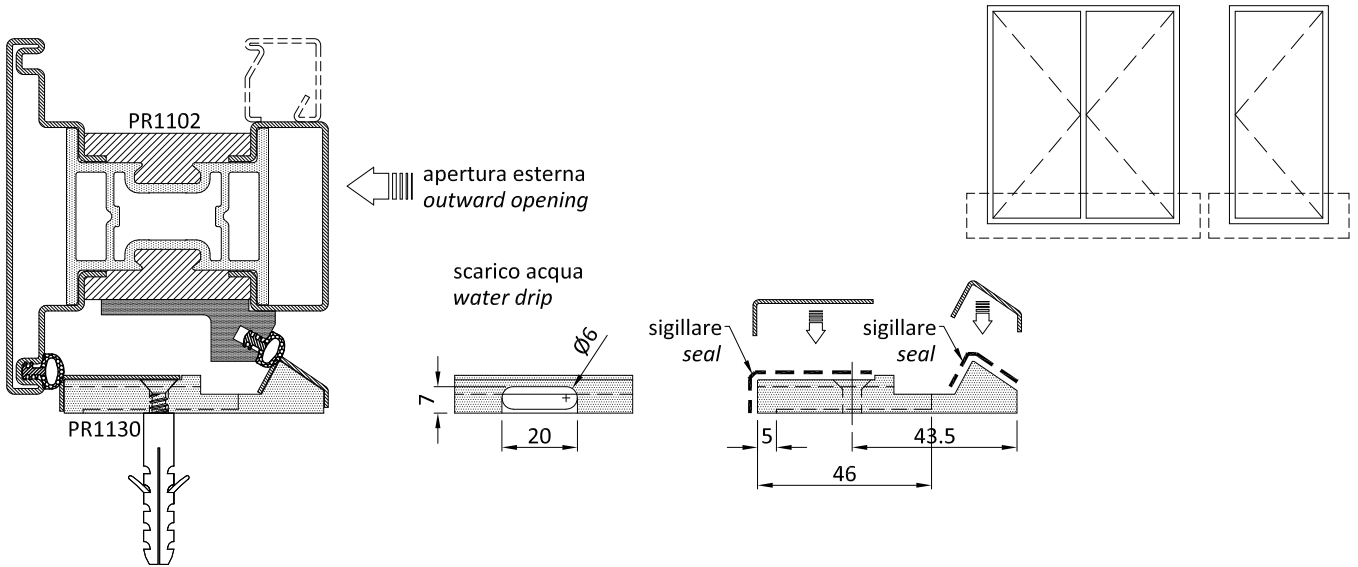

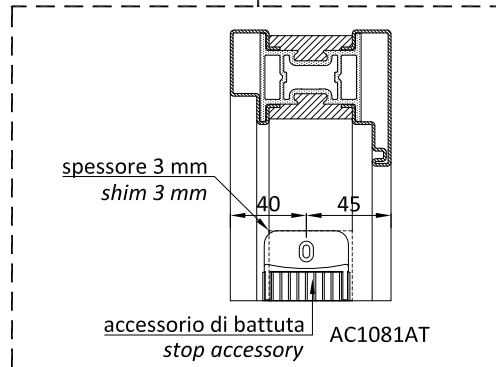
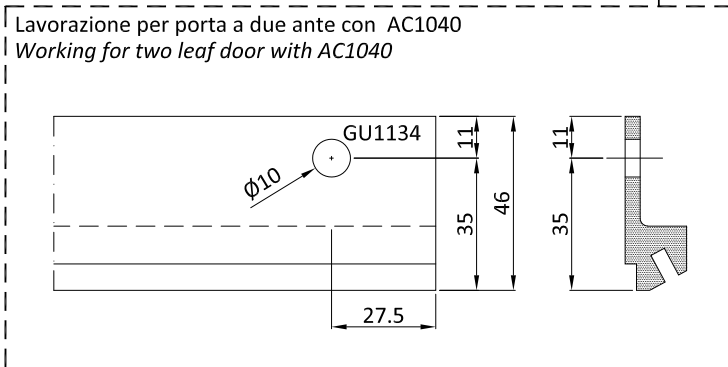
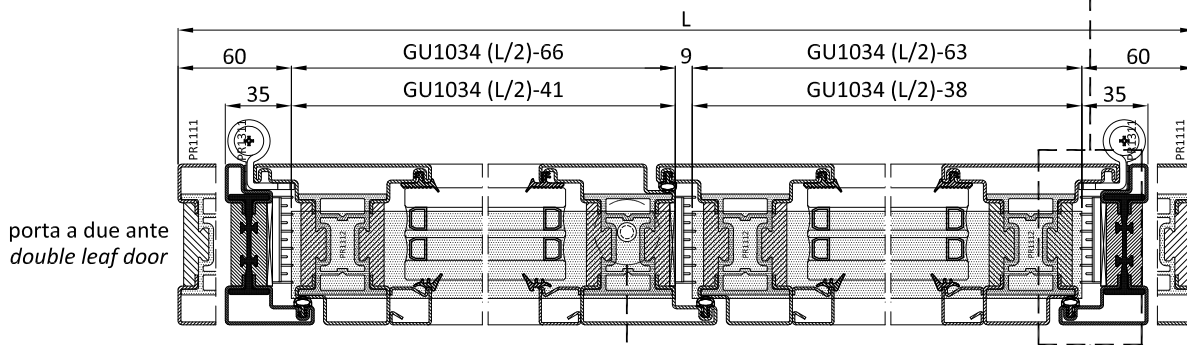
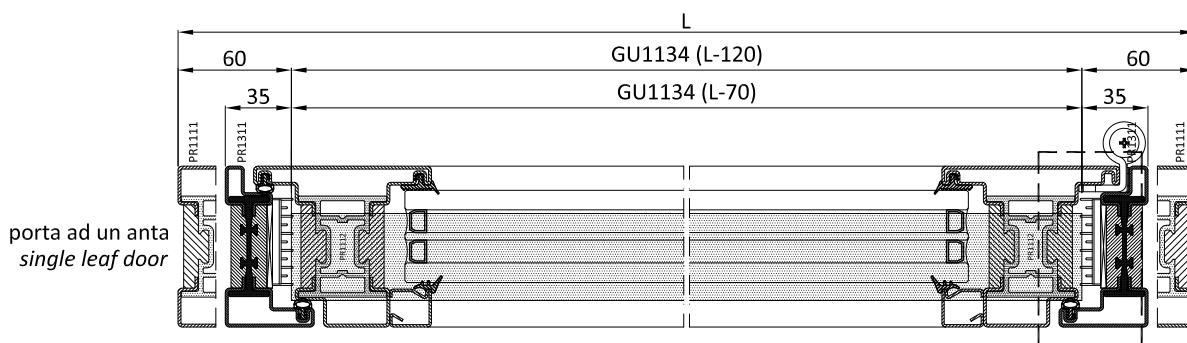
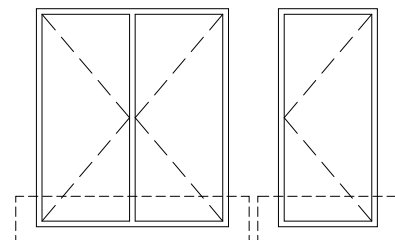
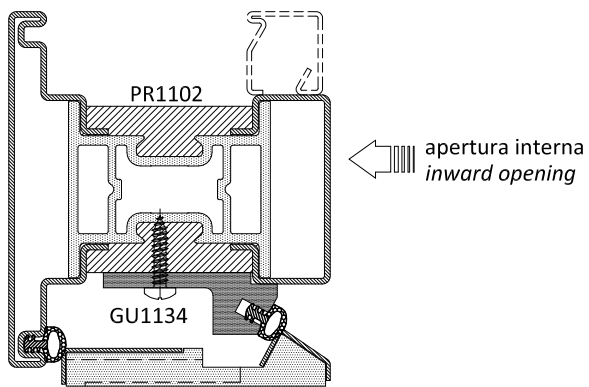

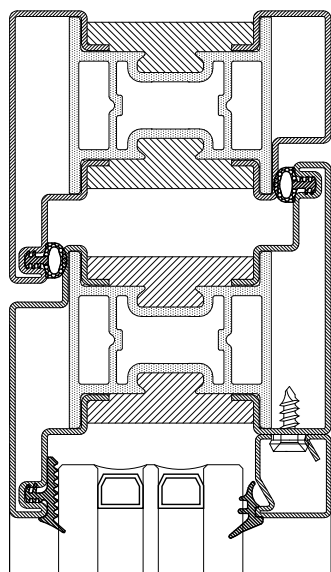
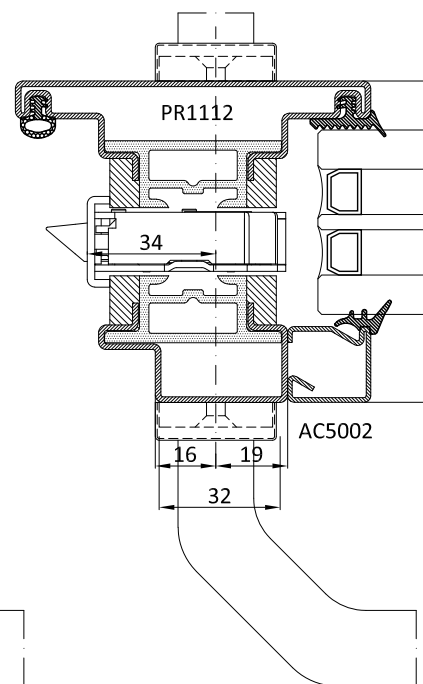
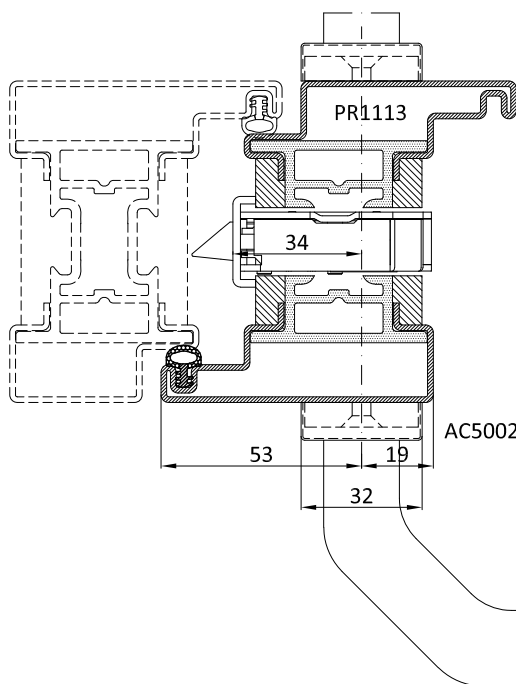
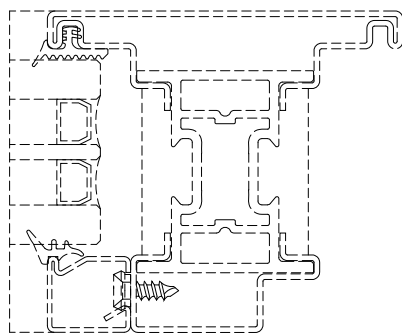
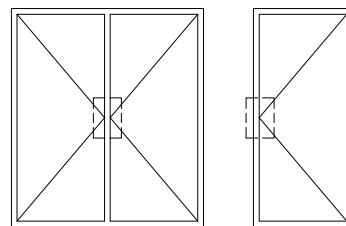

AC5002 :

- 1) Impugnatura
- 2) Rosetta
- 3) Corpo maniglia
- 4) Vite TPS 3.9x15.9
- 5) Quadro

AC5002 :

- 1) Handle grip
- 2) Washer
- 3) Handle body
- 4) Countersunk head screws 3.9x15.9
- 5) Spindle bar

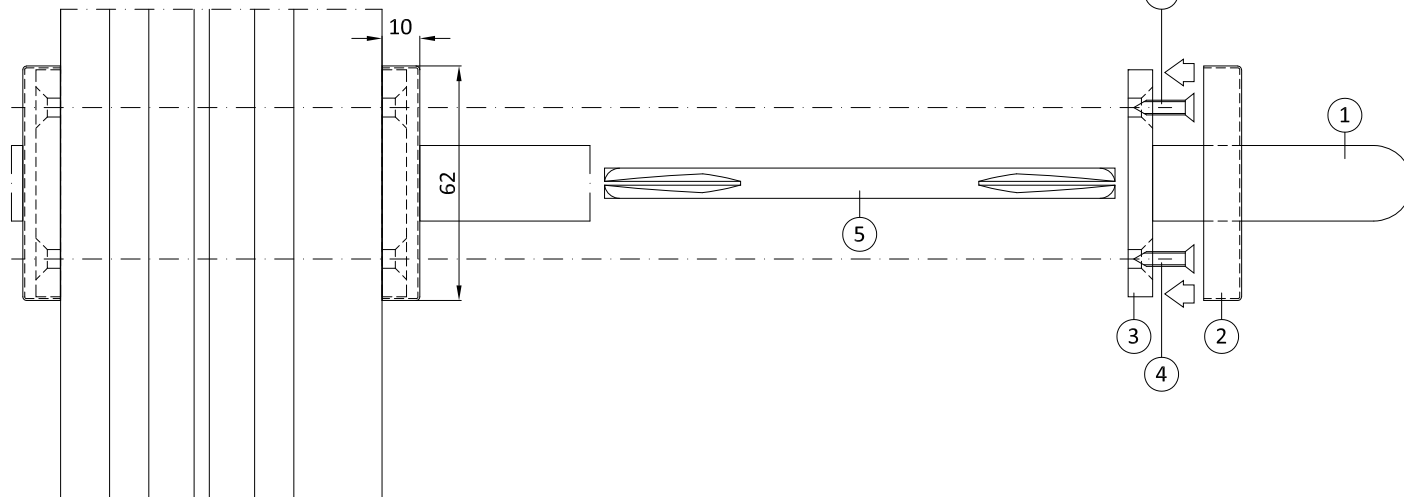

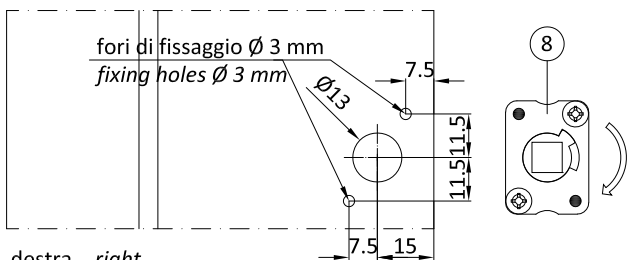

destra _right
Lavorazione speculare per anta SX
Same working for left hand

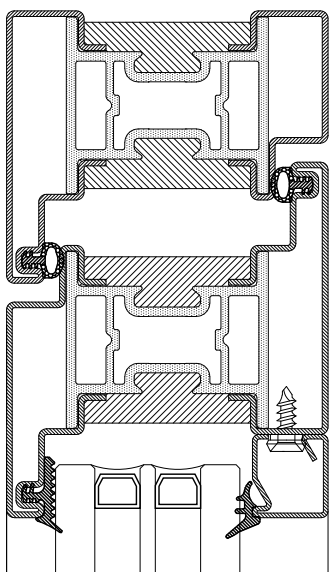
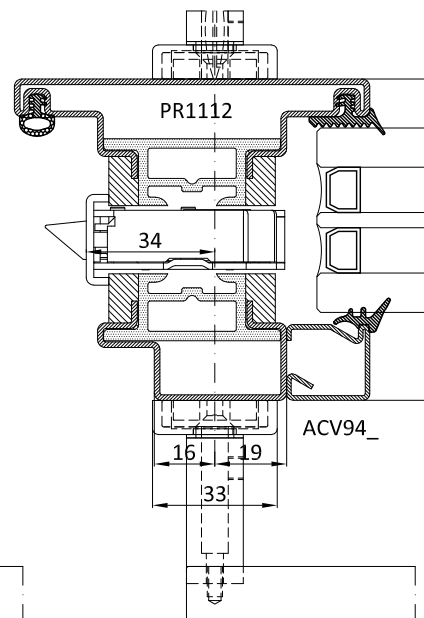
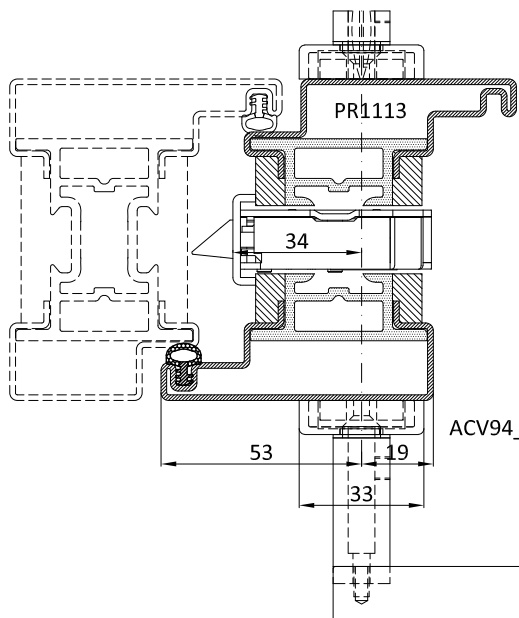
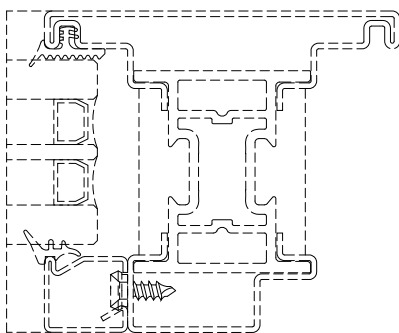
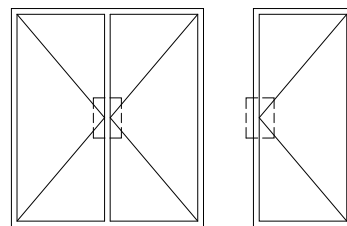

ACV94- :

- 1) Impugnatura
- 2) Rondella
- 3) Rosetta
- 4) Grano M6x6
- 5) Quadro
- 6) Vite TC 3.5x12.7
- 7) Molla

ACV94- :

- 1) Handle grip
- 2) Ring
- 3) Rose
- 4) Dowel M6x6
- 5) Spindle bar
- 6) Flat head screws 3.5x12.7
- 7) Spring

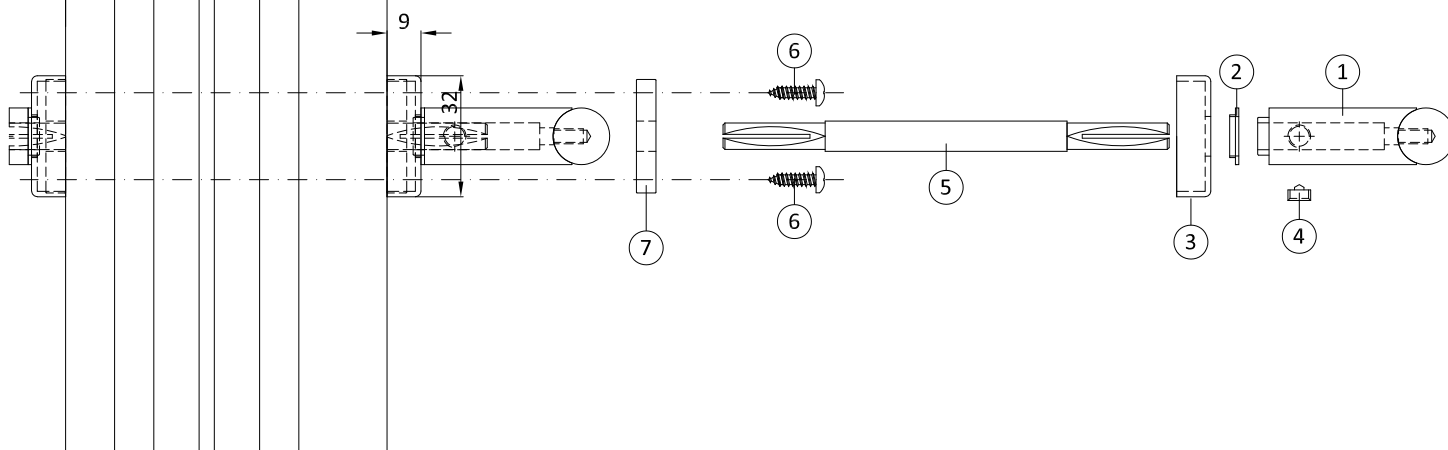

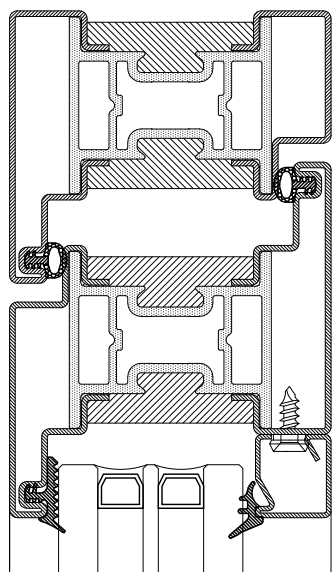
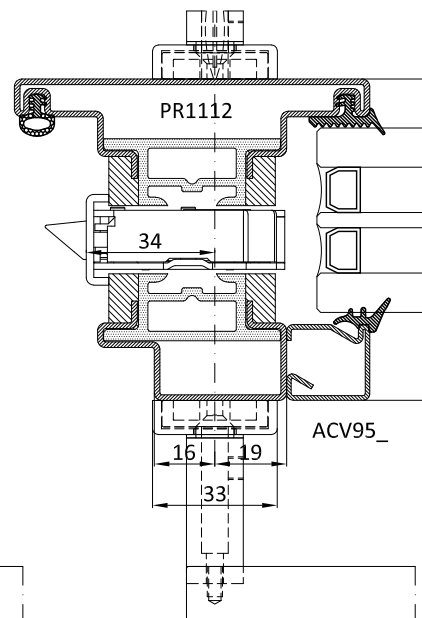
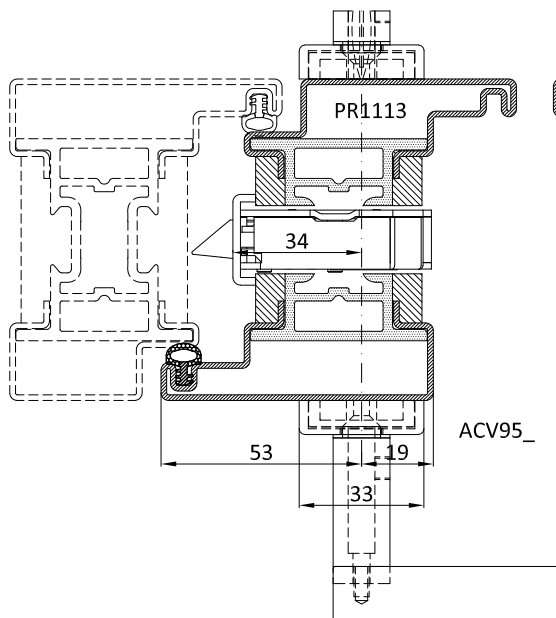
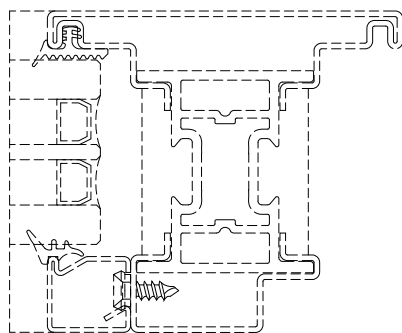
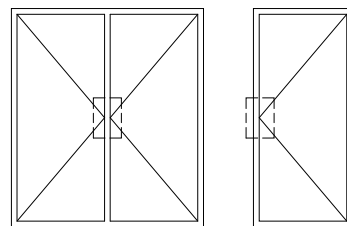

ACV95- :

- 1) Impugnatura
- 2) Rondella
- 3) Rosetta
- 4) Grano M6x6
- 5) Quadro
- 6) Vite TPS 3.9x15.9
- 7) Adattatore per molla
- 8) Molla

ACV95- :

- 1) Handle grip
- 2) Ring
- 3) Rose
- 4) Dowel M6x6
- 5) Spindle bar
- 6) Countersunk head screws 3.9x15.9
- 7) Adapter for spring
- 8) Spring

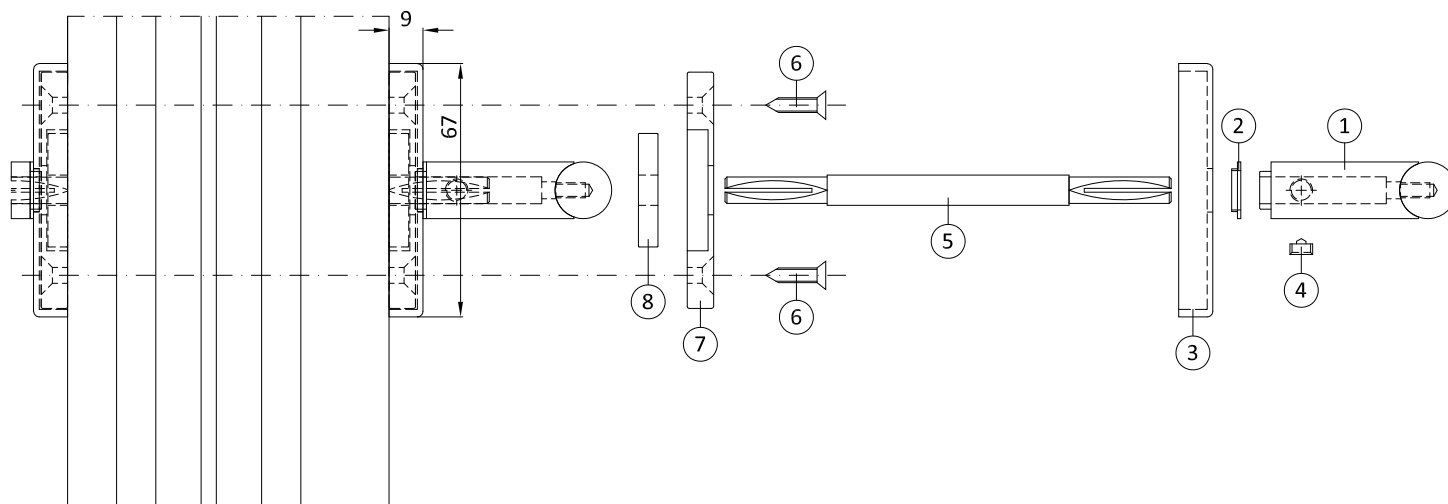

Porta | Door

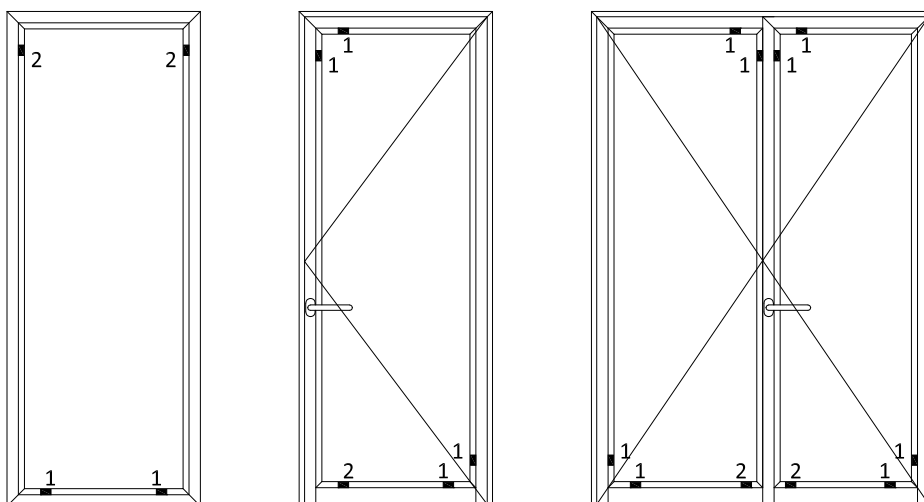

1) spessore portante | carry shim

2) spessore distanziatore | compensation shim

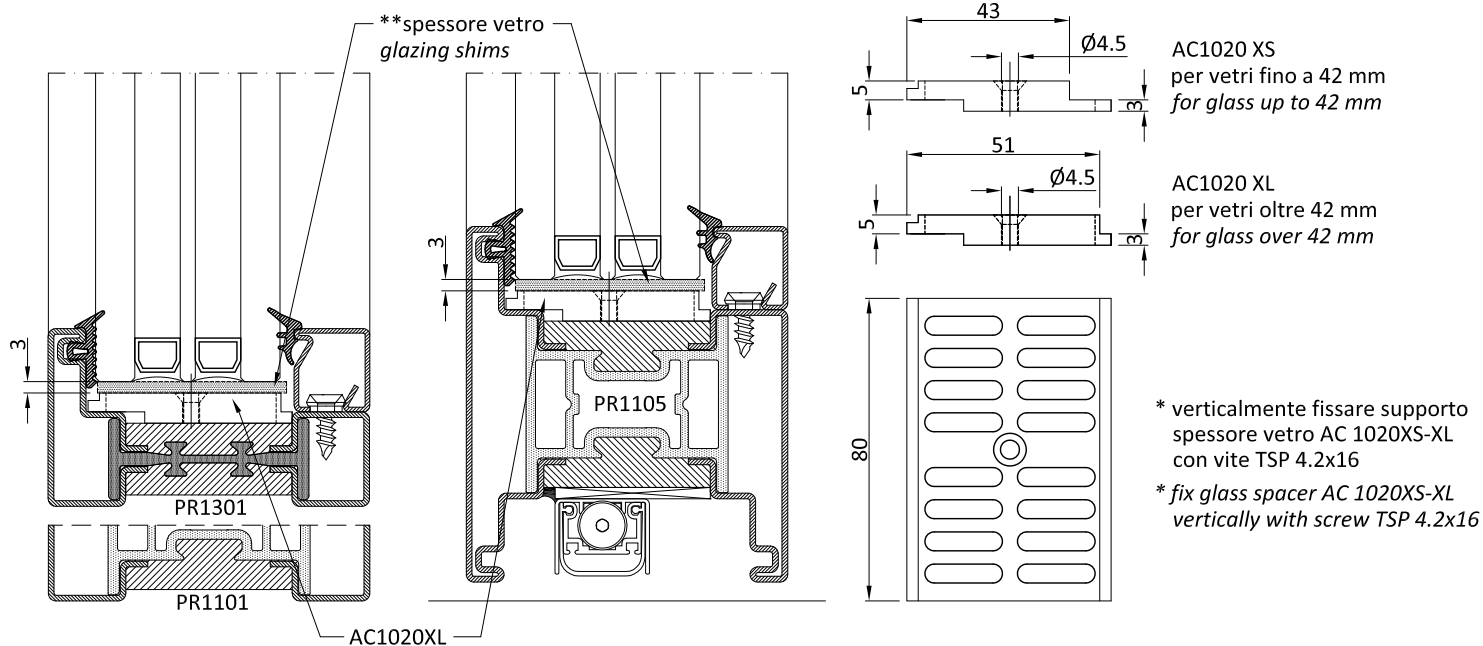

Note / Note

- La larghezza degli spessori è almeno pari o maggiore (+2 mm) dello spessore del vetro installato.
- La posizione degli spessori deve essere garantita dall'utilizzo di materiale adeguato che ne eviti lo spostamento.
- The shims' width is the same or greater (+2 mm) than the thickness of the glass installed.
- The position of the shims has to be ensured by using appropriate material that avoids creeping.

* vite TSP 4.2 x 16 mm non inclusa - screw TSP 4.2 x 16 mm not included

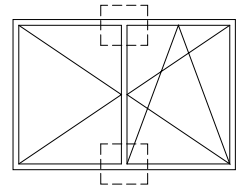
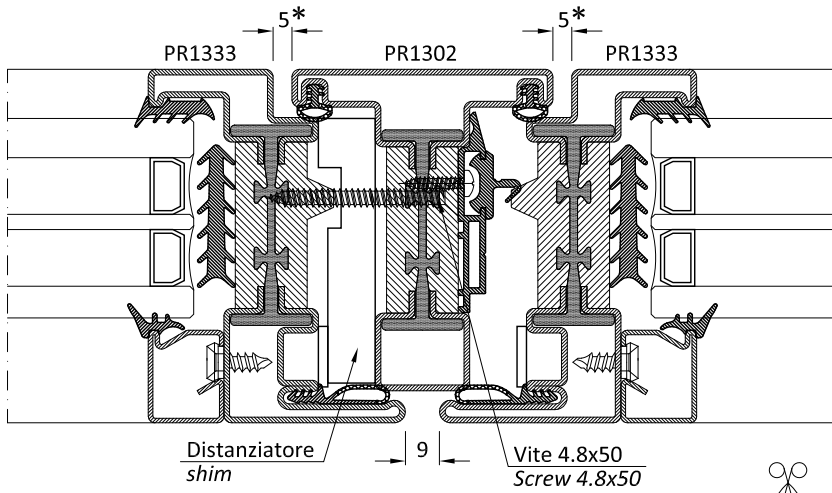

A = Fori di fissaggio PR1302 con PR1333
A = Anchoring holes PR1302 with PR1333

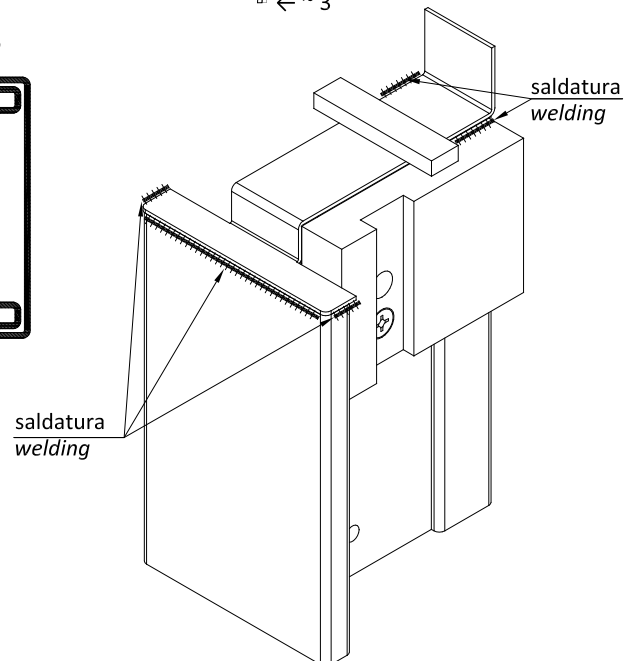
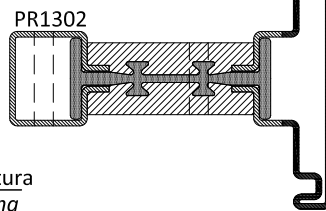
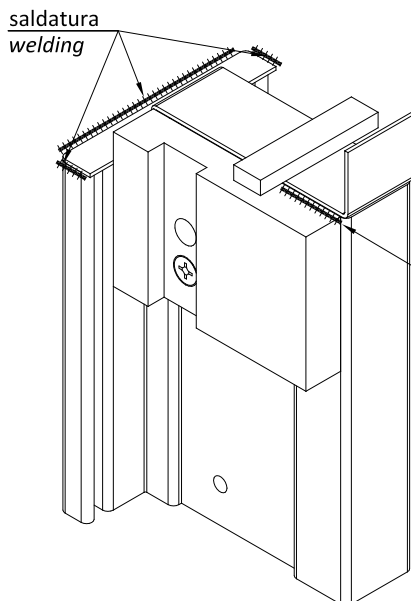
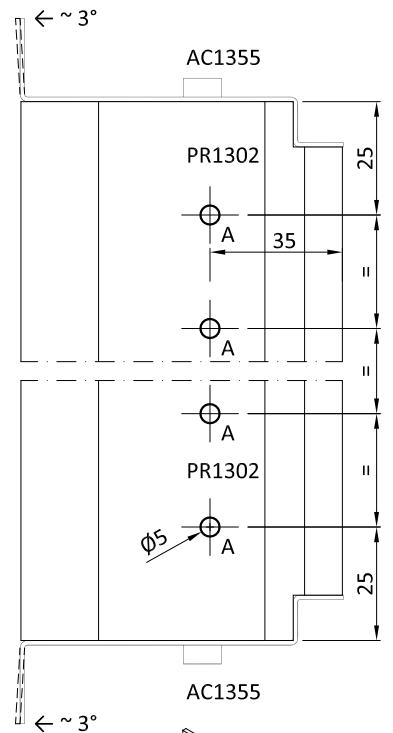
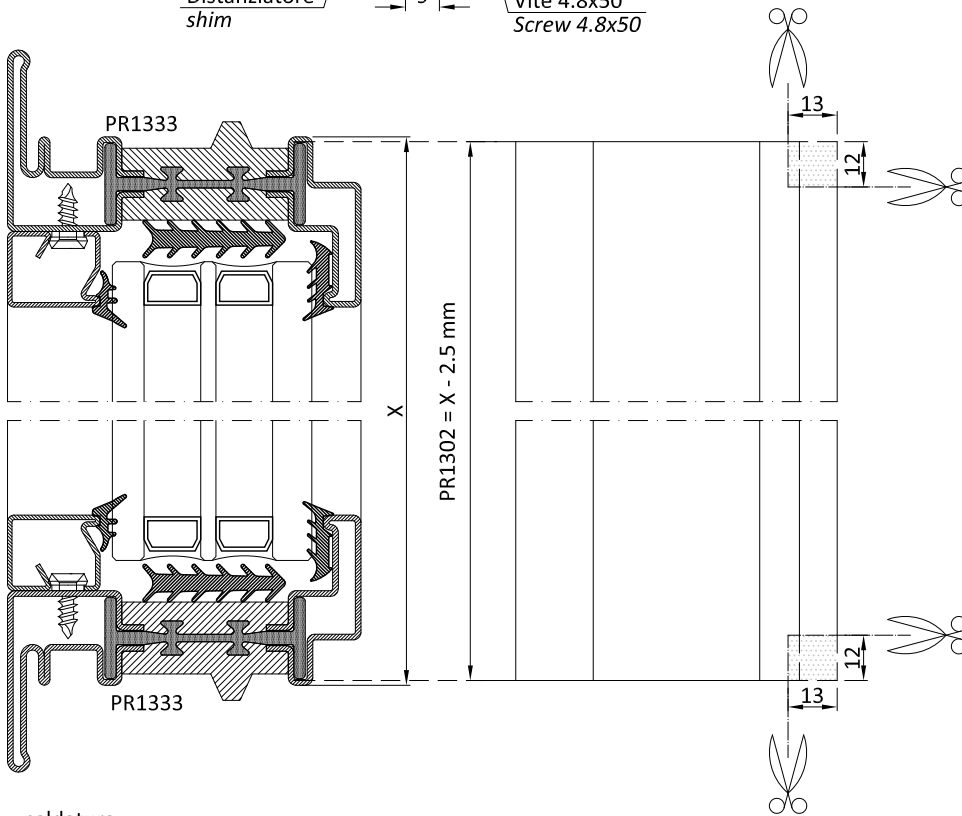

Saldare e sigillare l'accessorio AC1355 al profilo montante PR1302
Weld and seal AC1355 to PR1302 transom profile

* Vedi tabella 4.1.5
* See chart 4.1.5

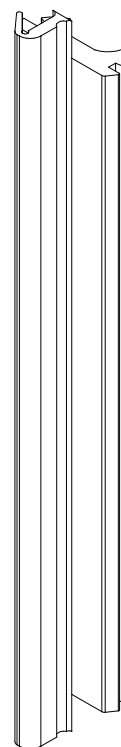
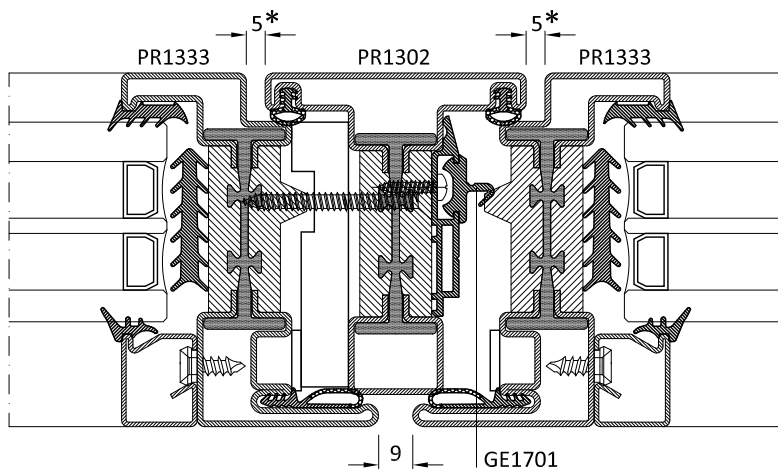
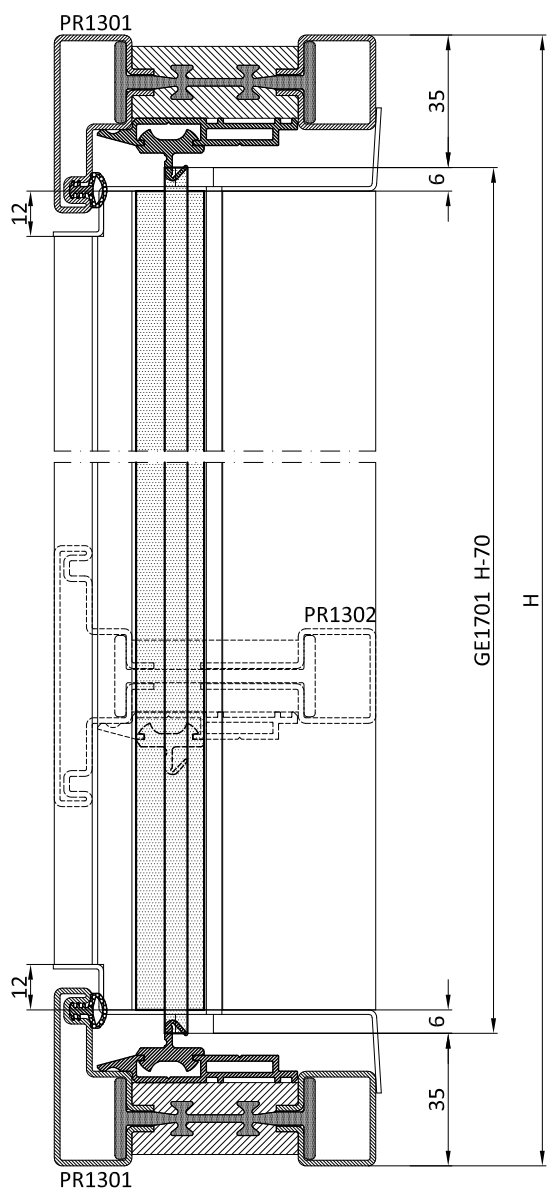
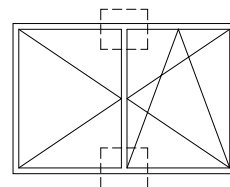

* Vedi tabella 4.1.5
* See chart 4.1.5

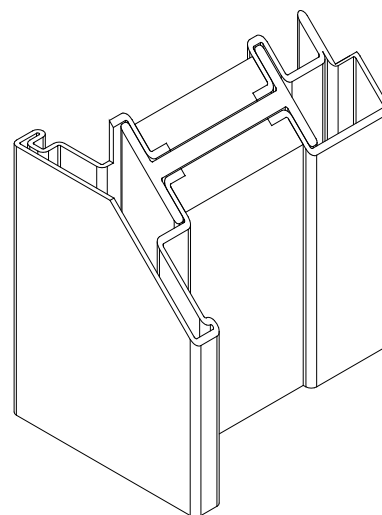
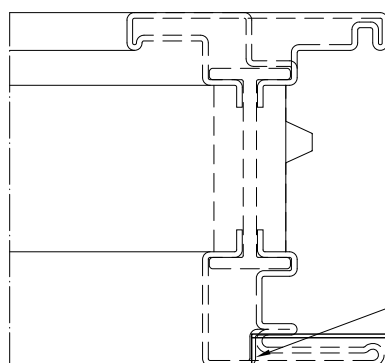
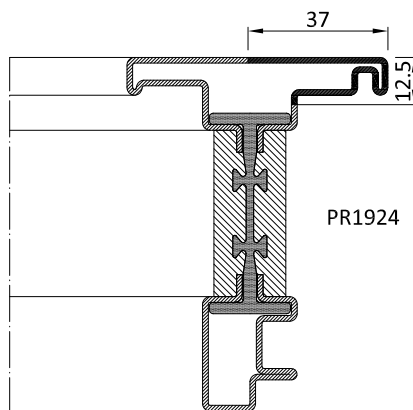
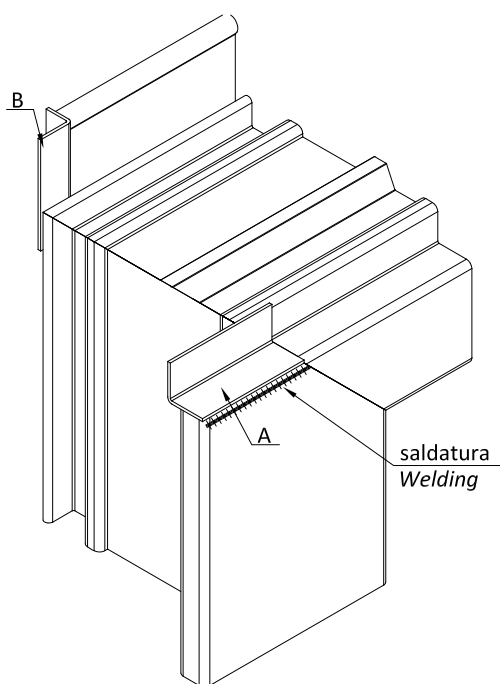
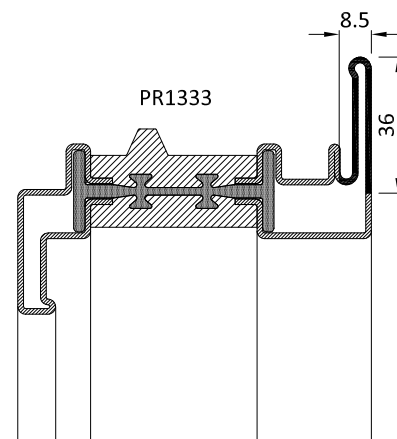
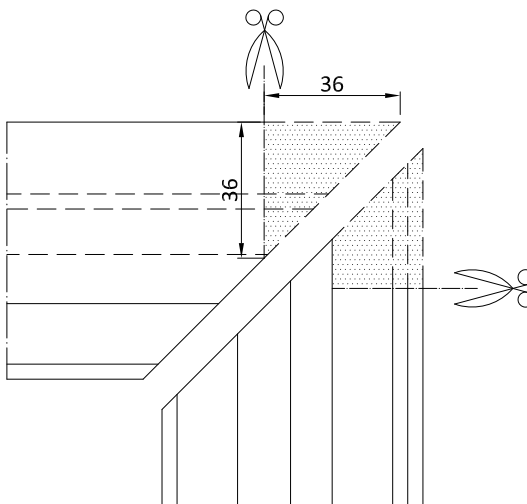
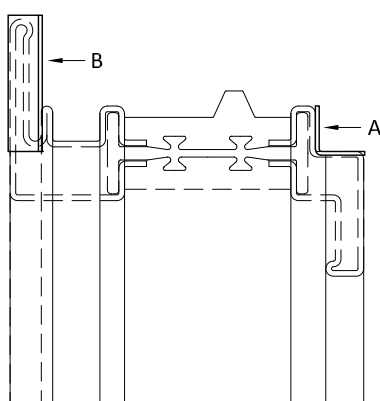
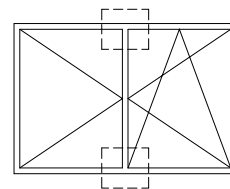
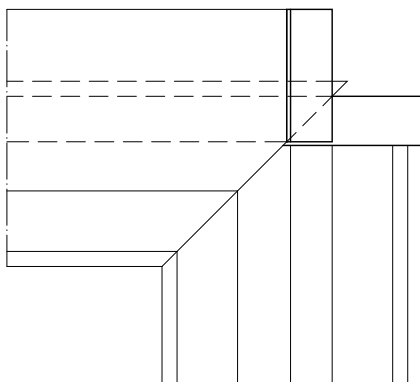
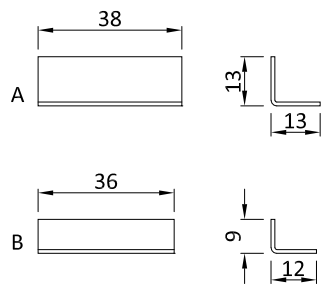

porzione da rifilare e saldare dopo l'assieme dell'angolo
area to cut and weld after the corner joint

Nota: i fondini sono forniti di dimensioni maggiori da rifilare dopo la saldatura.
Note: the ending caps for T-Z joint are furnished in larger dimensions and should be trimmed down after welding.

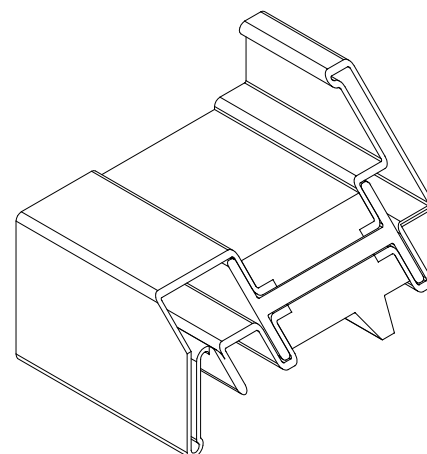
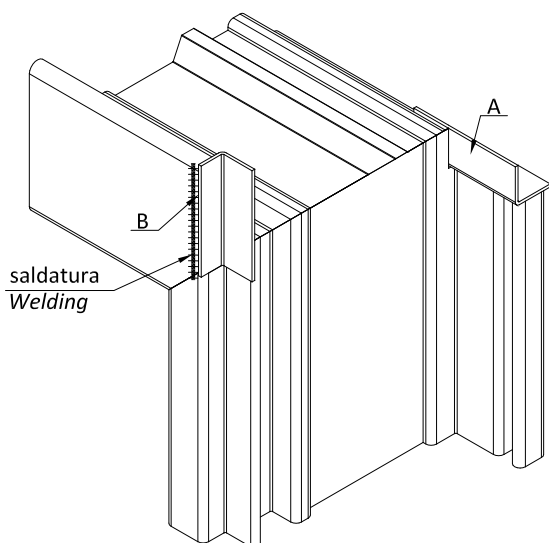
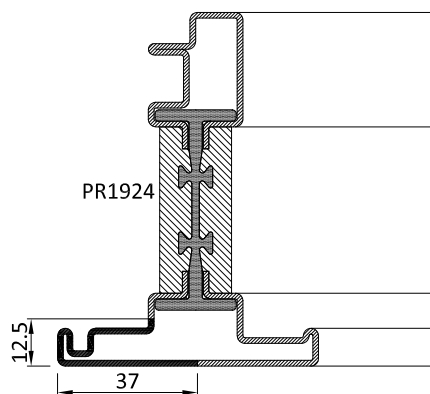
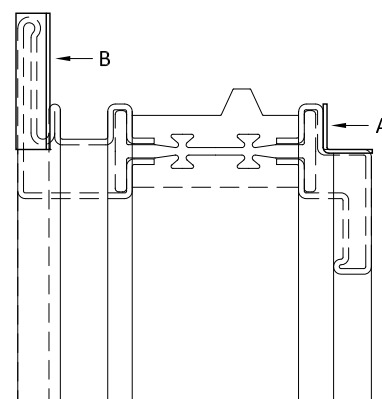
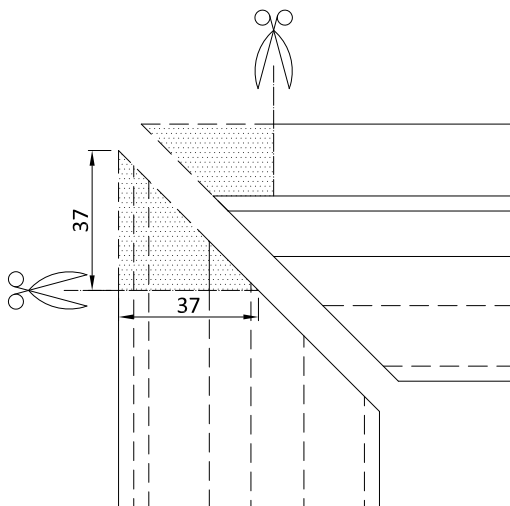
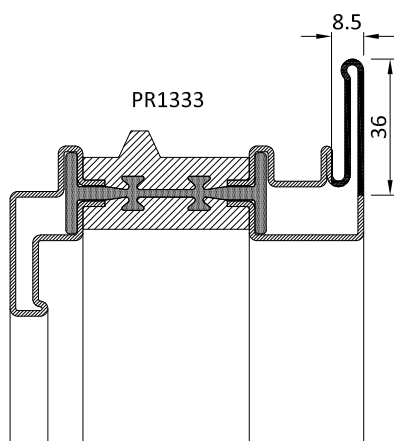
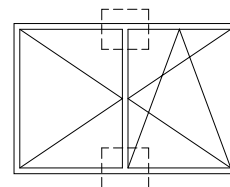
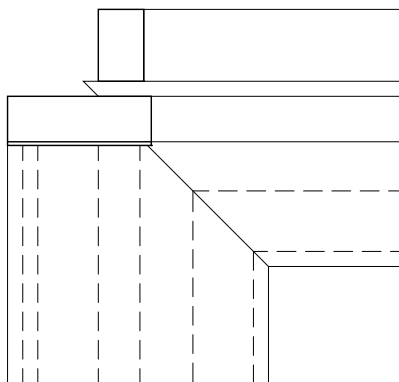
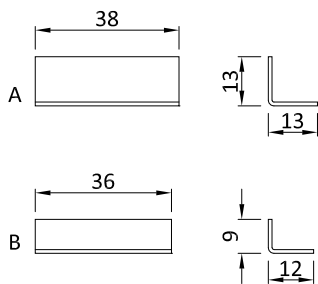

Nota: i fondini sono forniti di dimensioni maggiori da rifilare dopo la saldatura.
Note: the ending caps for T-Z joint are furnished in larger dimensions and should be trimmed down after welding.

- 1) Asportare il poliammide.
- 1) *Remove the polyamide.*
- 2) Tagliare la guarnizione GE1704 a 50 mm. dal filo esterno del polliamide.
- 2) *Cut the gasket GE1702 at 50 mm from the end thread of polyamide.*
- 3) Asportare la la parte dell'estruso GU1702 che interferisce con il fondino A.
- 3) *Remove the part of the extrudate GU1702 that interferes with the rubber ending cap A.*
- 4) Posizionare il fondino di gomma ed incollarlo alla guarnizione GE1701 a mezzo di colla ciano-acrilica.
- 4) *Position the rubber ending cap and stick it to the gasket GE1701 with cyano-acrylic glue*

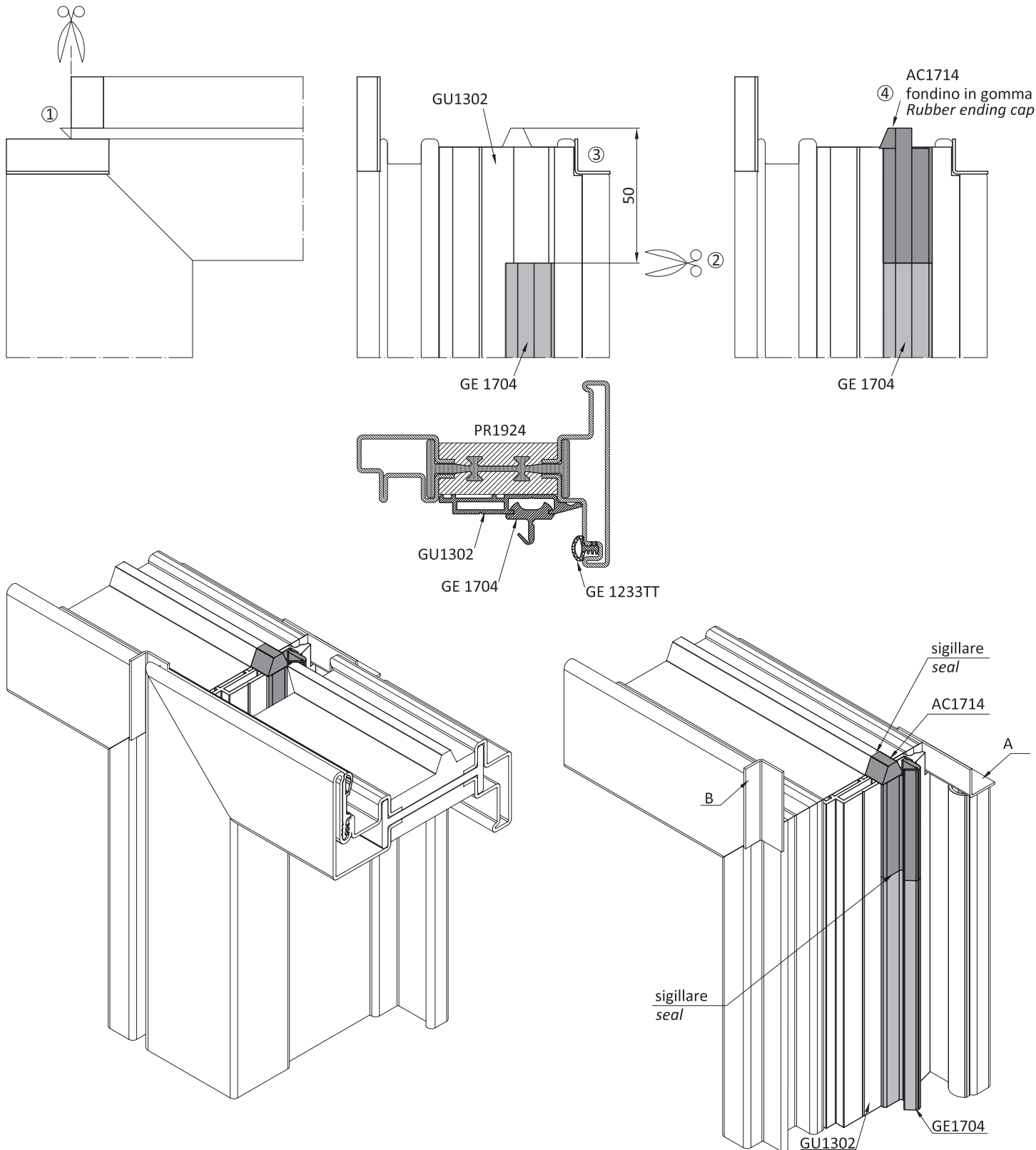
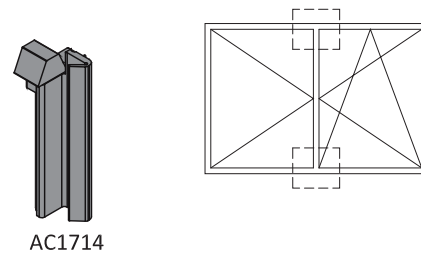

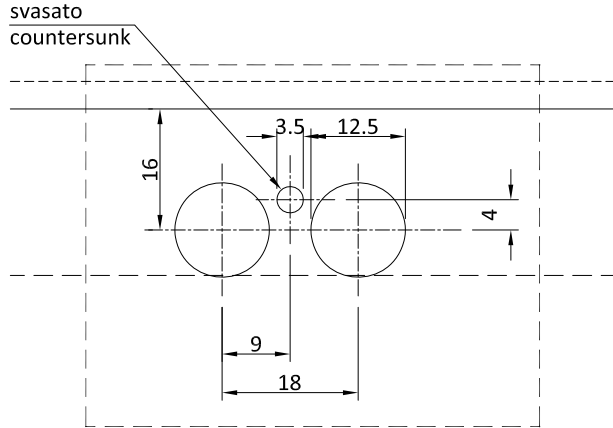
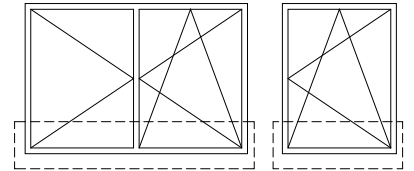

Particolare A - Detail "A"

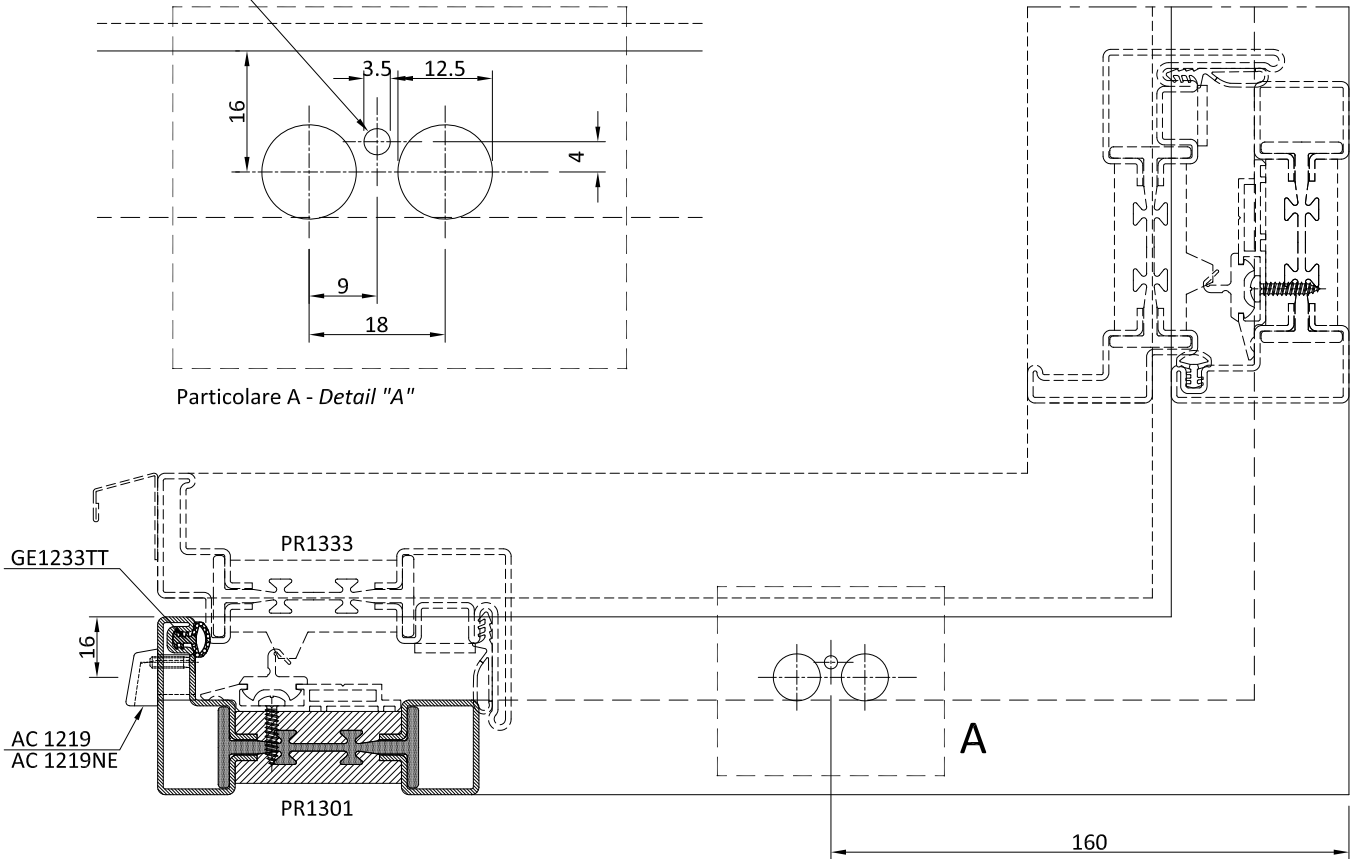

Tagliare la guarnizione per 20 mm | Cut the gasket to 20 mm

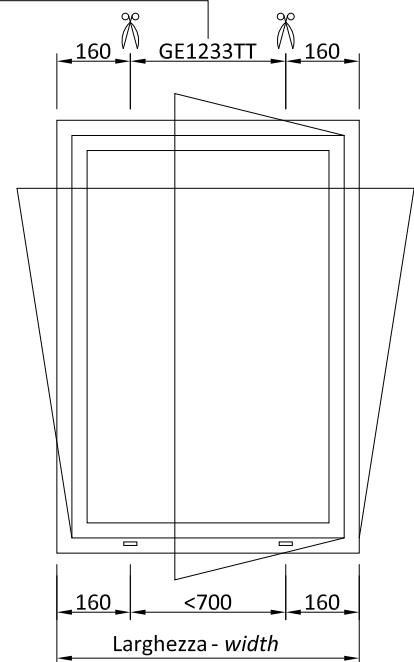
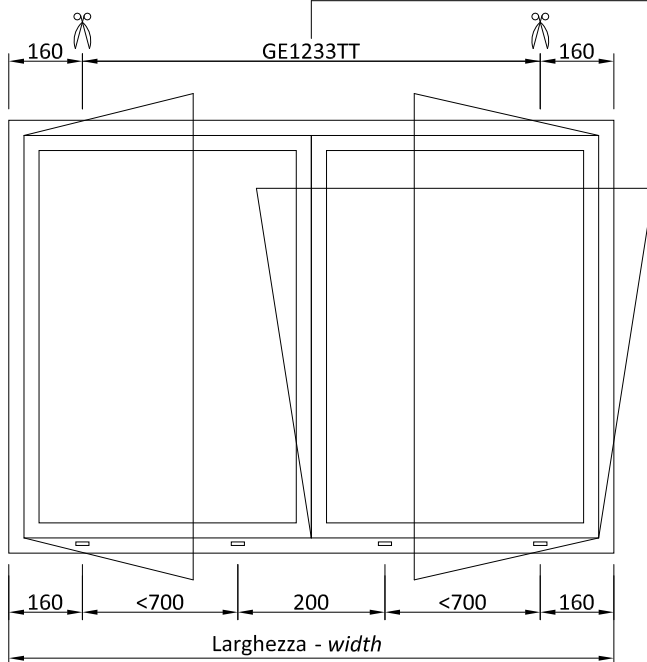

- 1) Eseguire i fori come da disegno
- 2) Posizionare lo scarico acqua e sigillare fissare con viti in dotazione M3x12
- 3) Posizionare il supporto della guarnizione di giunto GU1702 e fissarlo con viti TC 3.5x13 (non fornita)
- 4) Sigillare la guarnizione di giunto GE1701 con il supporto GU1702 per tutta lunghezza e per 200 mm in altezza sul telaio
- 5) Posizionare la guarnizione di giunto centrale GE1701 e gli angoli vulcanizzati AC1716, incollare gli angoli alla guarnizione a mezzo di colla ciano-acrilica

- 1) Drill the holes according to drawing
- 2) Install the water drip accessory, seal and secure with the supplied M3x12 screw
- 3) Position the support of the weather strip GU1702 and anchor it with the double-sided adhesive tape provided and screws TC 3.5x13 (not provided)
- 4) Seal the weather strip GE1701 with the support GU1702 for the whole length and for 200 mm vertically on the frame
- 5) Install the central weather strip GE1701 and the vulcanised corners AC1716, glue the corners to the weather strip using cyanoacrylate glue

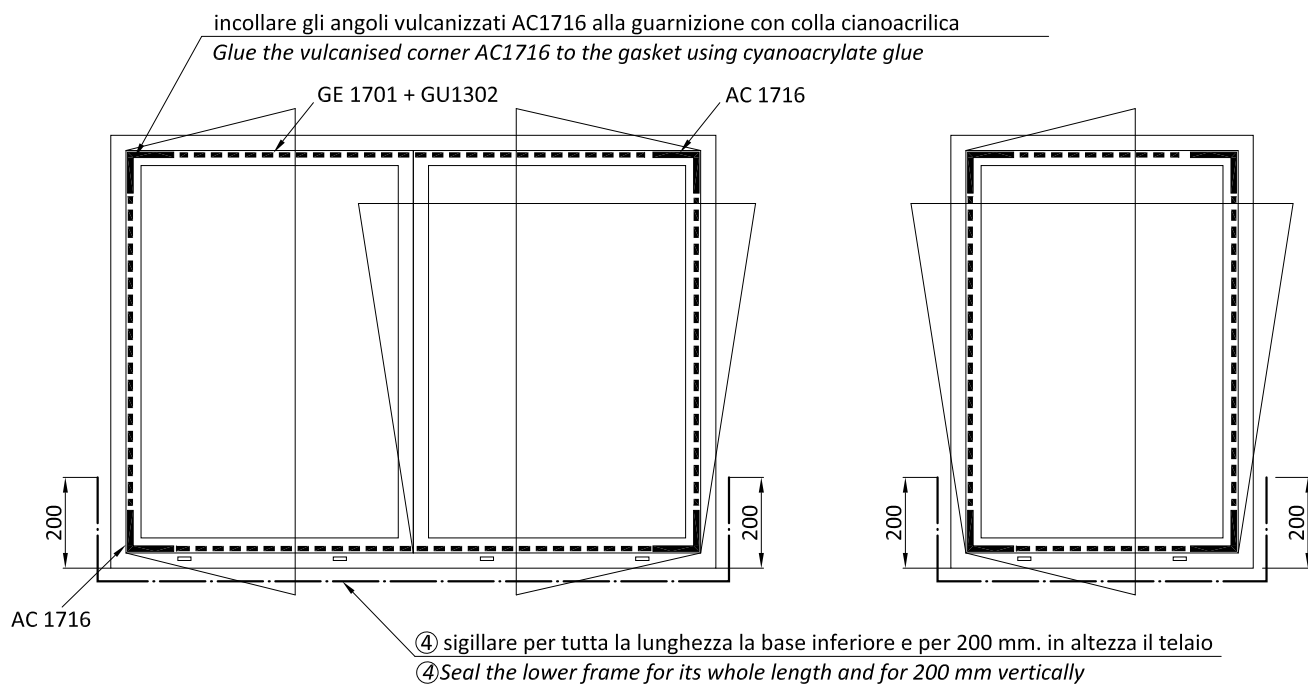
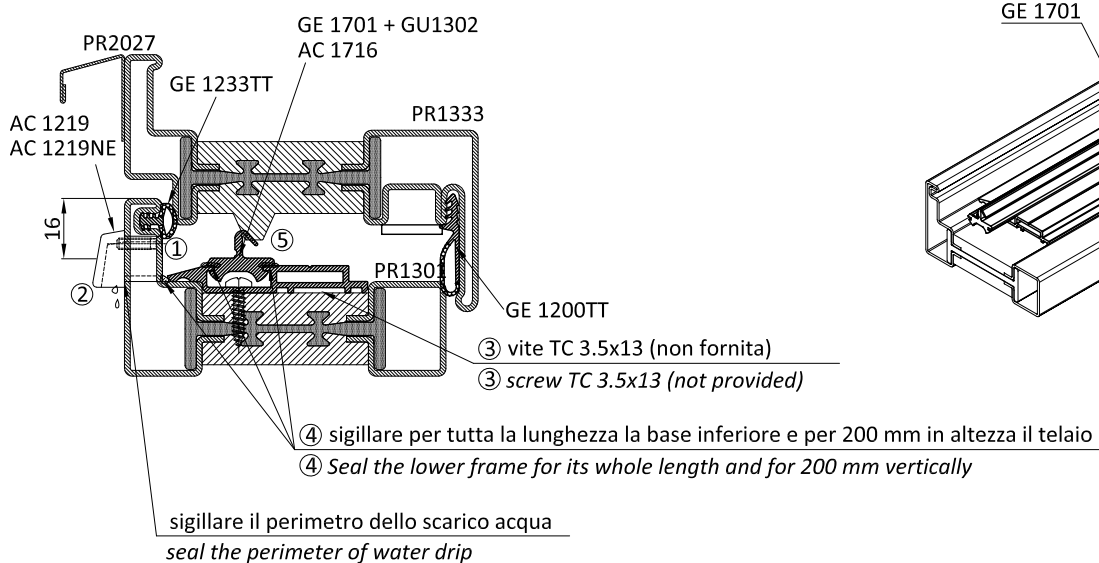
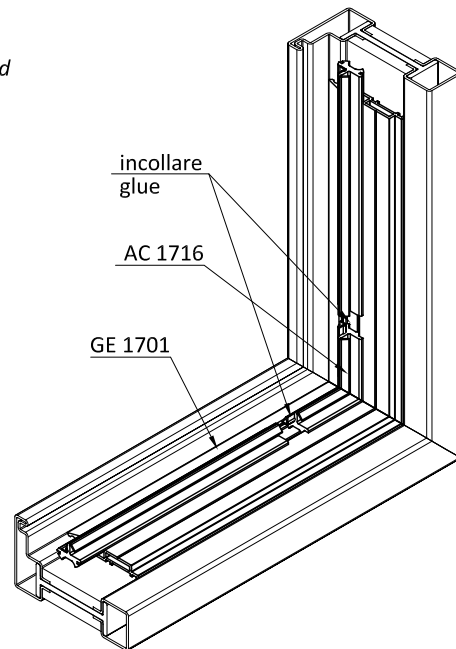
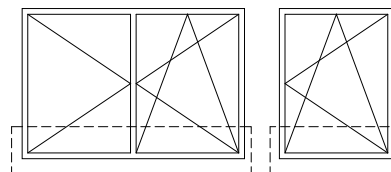

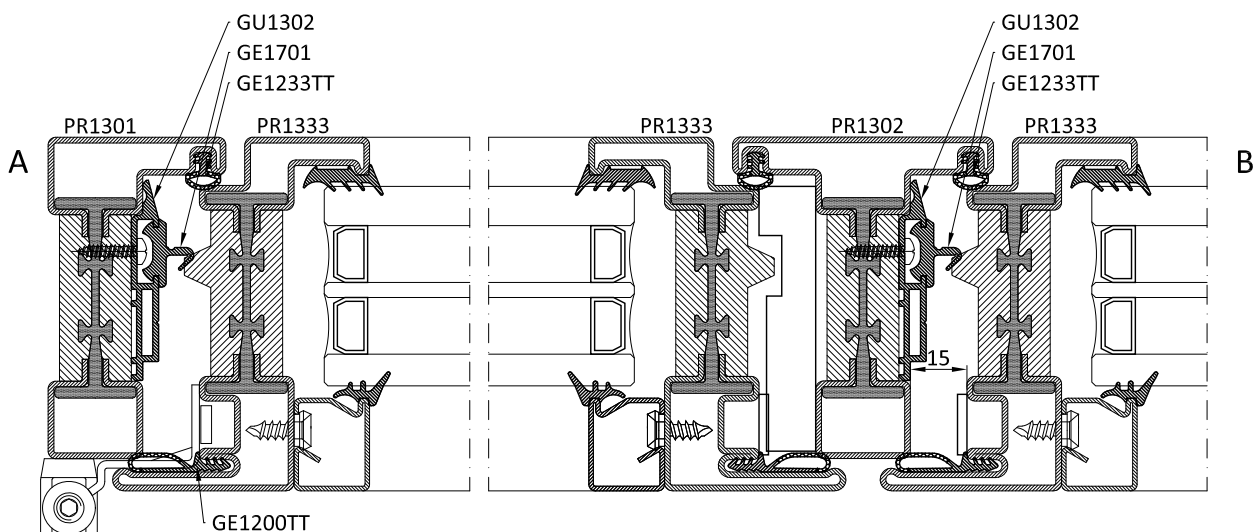
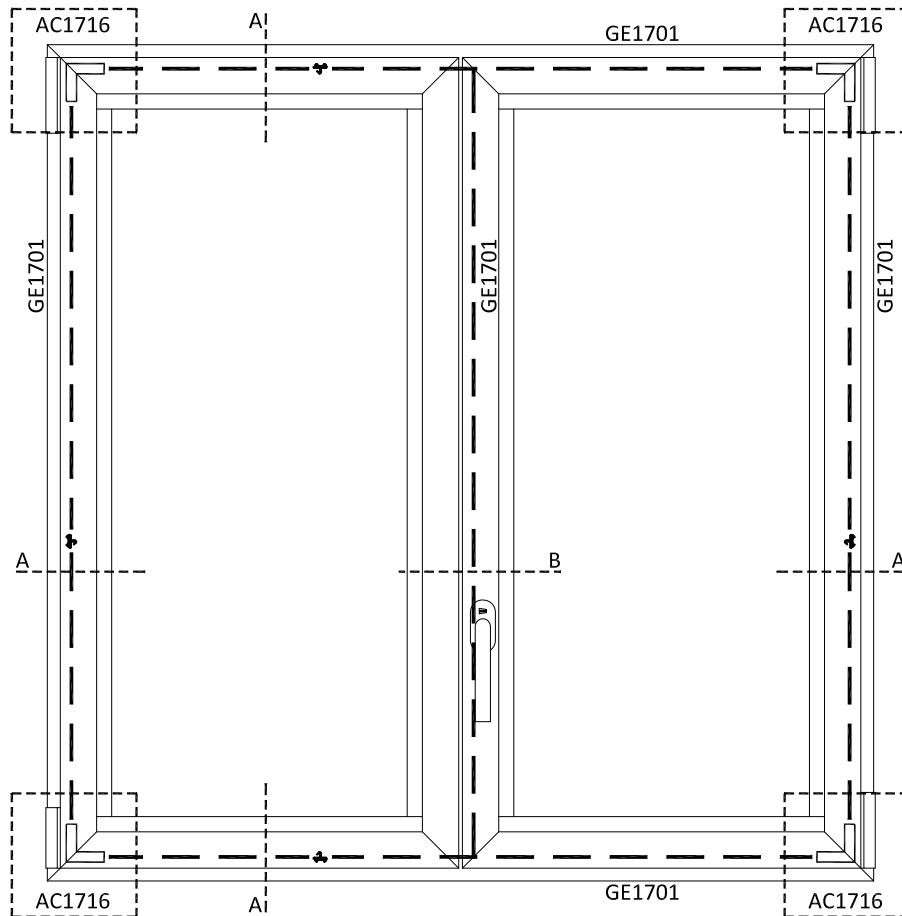
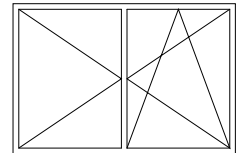

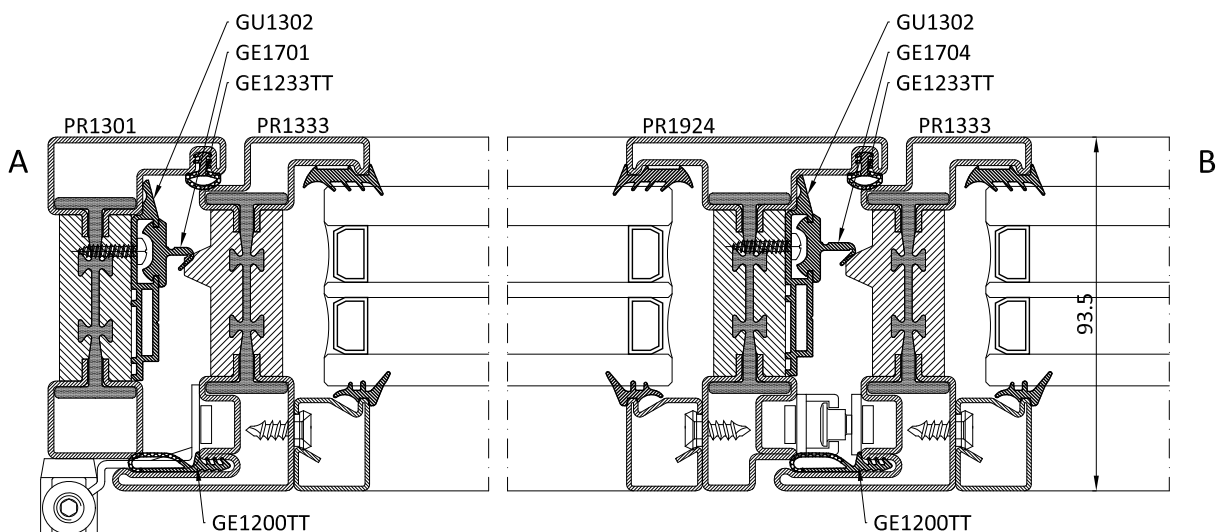
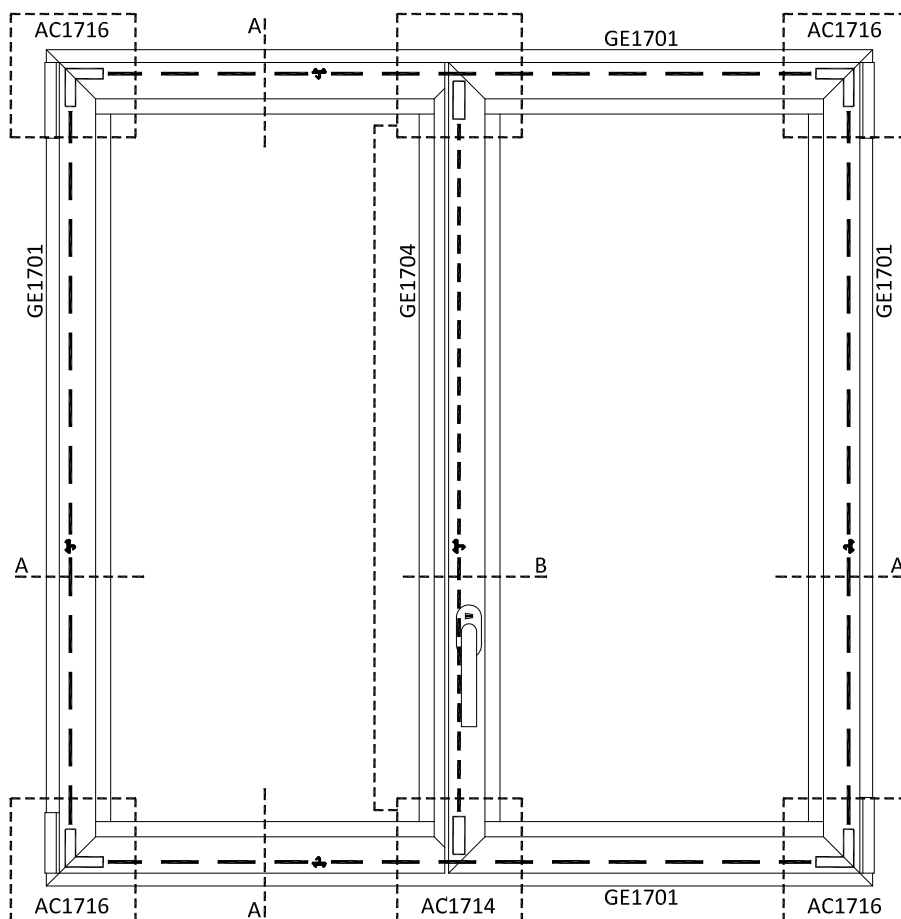
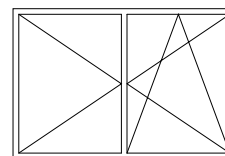

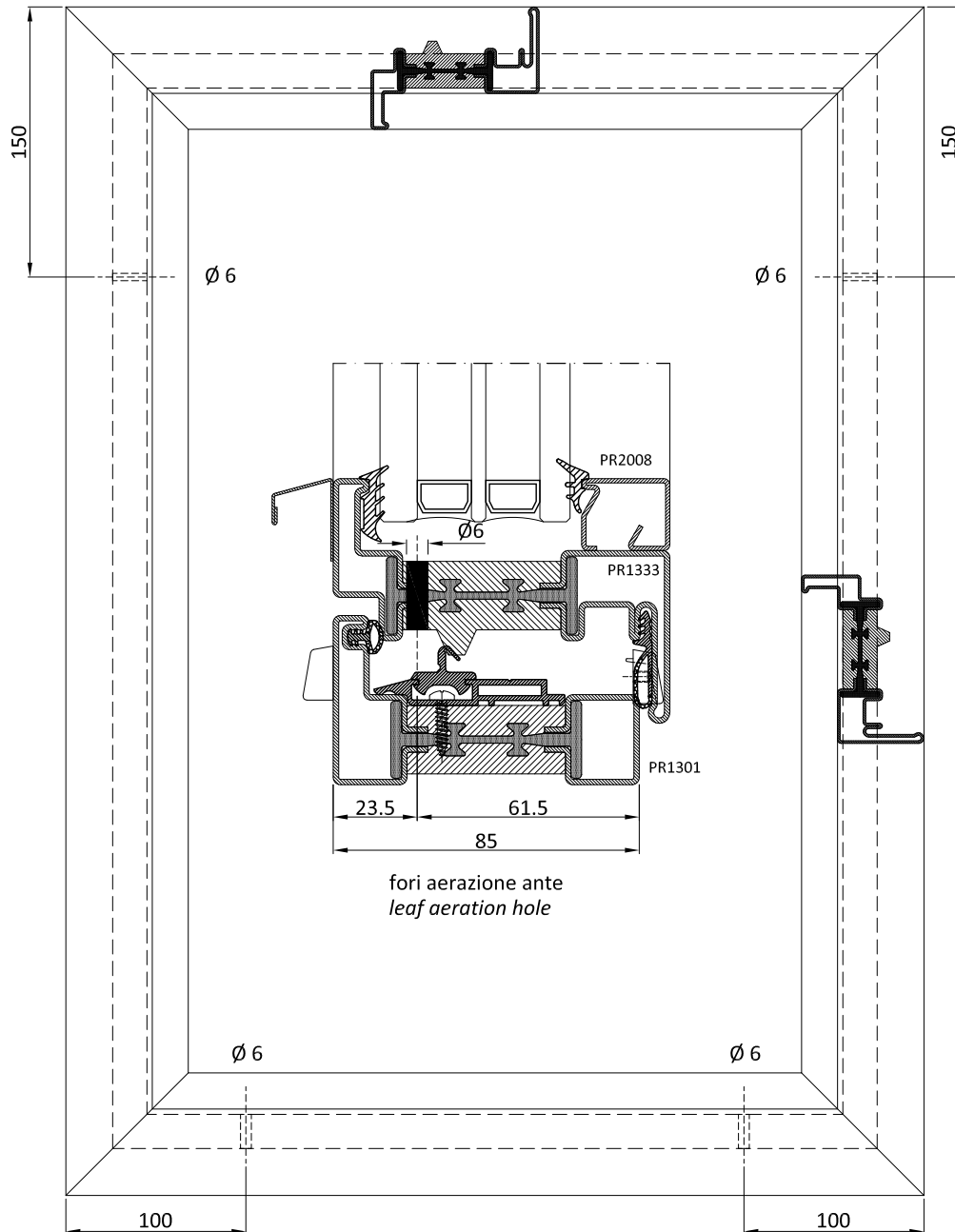
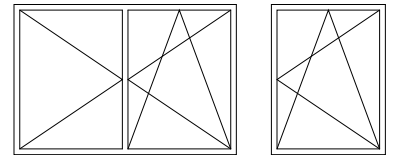

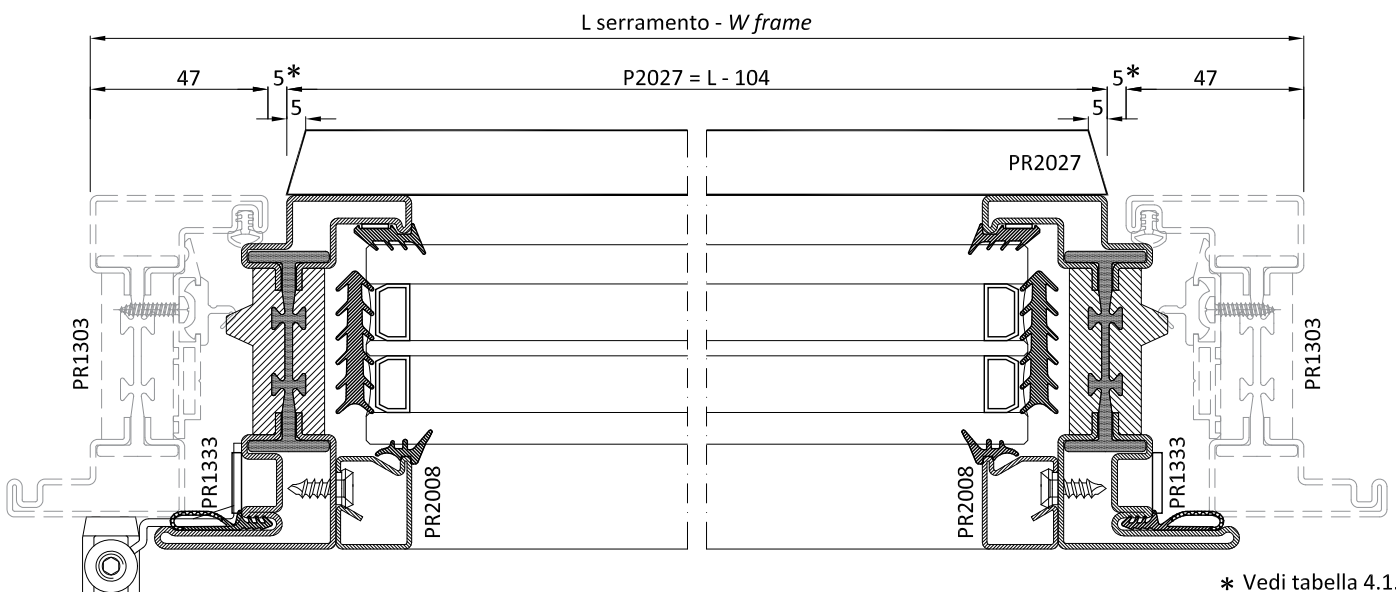
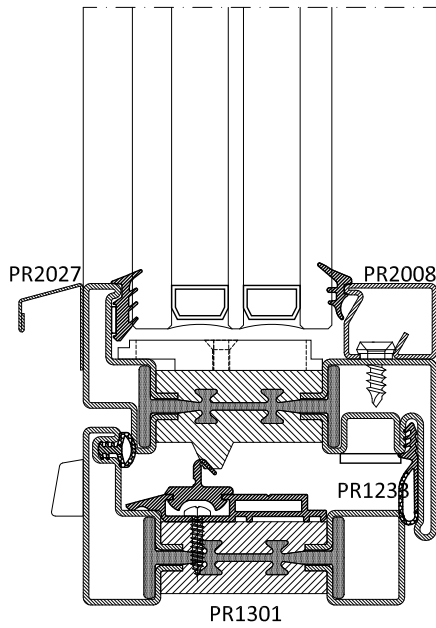
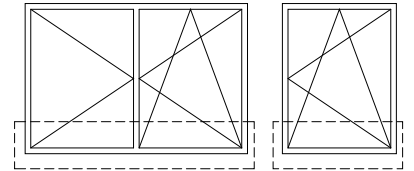

* Vedi tabella 4.1.5
 * See chart 4.1.5

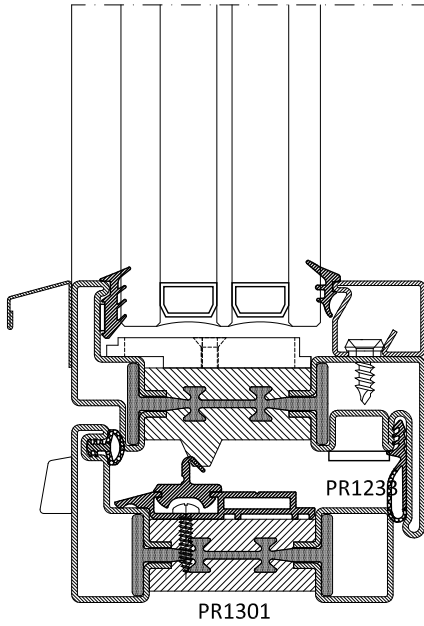
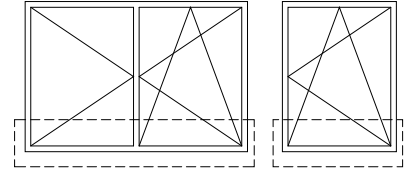

L serramento - W frame

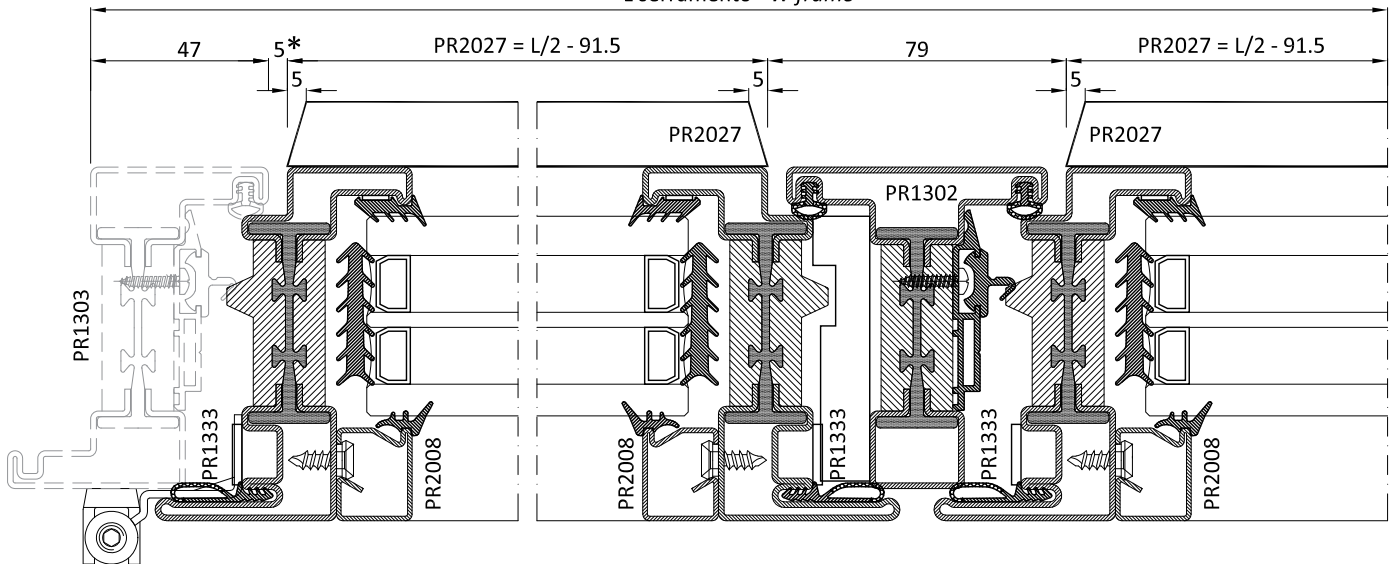

L serramento - W frame

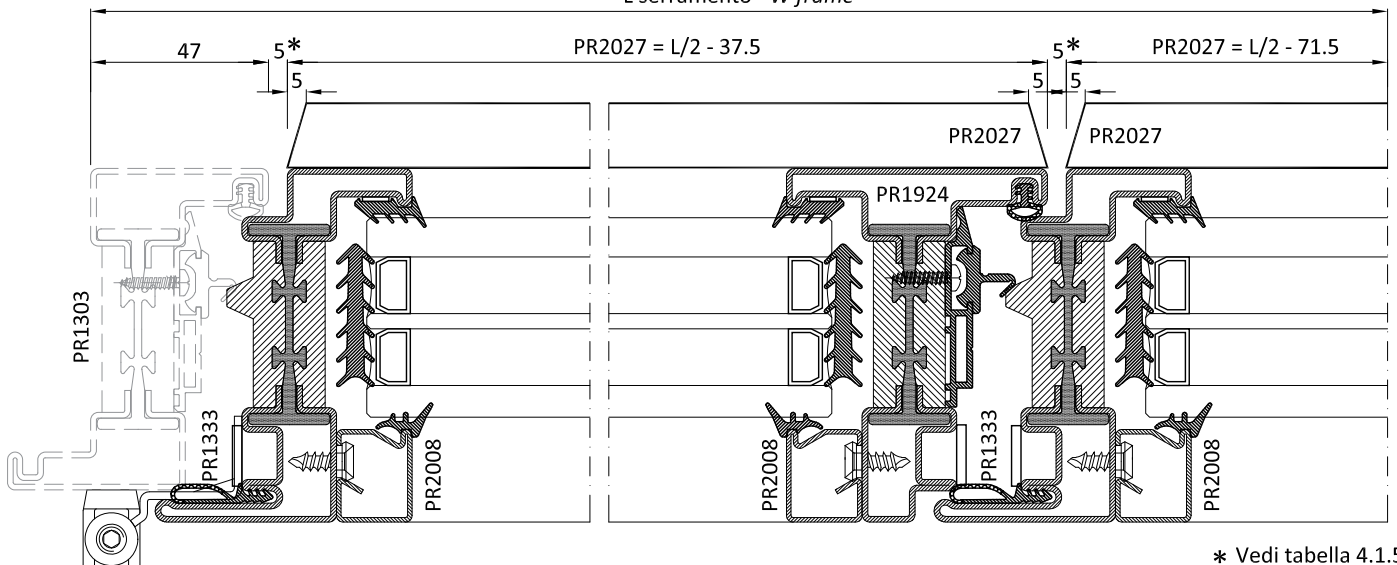

* Vedi tabella 4.1.5
* See chart 4.1.5

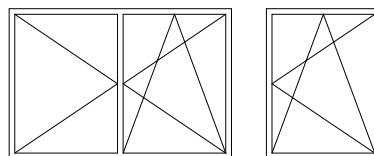

Easy	H altezza - height									
	661 860	861 1000	1001 1200	1201 1400	1401 1600	1601 1800	1801 2000	2001 2200	2201 2400	
L larghezza width	601-800	A1	B1	C1	D1	E1	F1	G1	H1	I1
	801-1000	-	B2	C2	D2	E2	F2	G2	H2	I2
	1001-1200	-	-	C3	D3	E3	F3	G3	H3	I3
	1201-1400	-	-	-	D4	E4	-	-	-	-

AGA271-5	AGA775	180 kg	Easy
AGE271-2-5-6	AGE775-6	150 kg	Easy
AGE281-2-5-6	AGE785-6	130 kg	Easy
AGE291-2-5-6	AGE795-6	130 kg	Easy
AG1273		80 kg	Easy
AG1278		80 kg	Easy

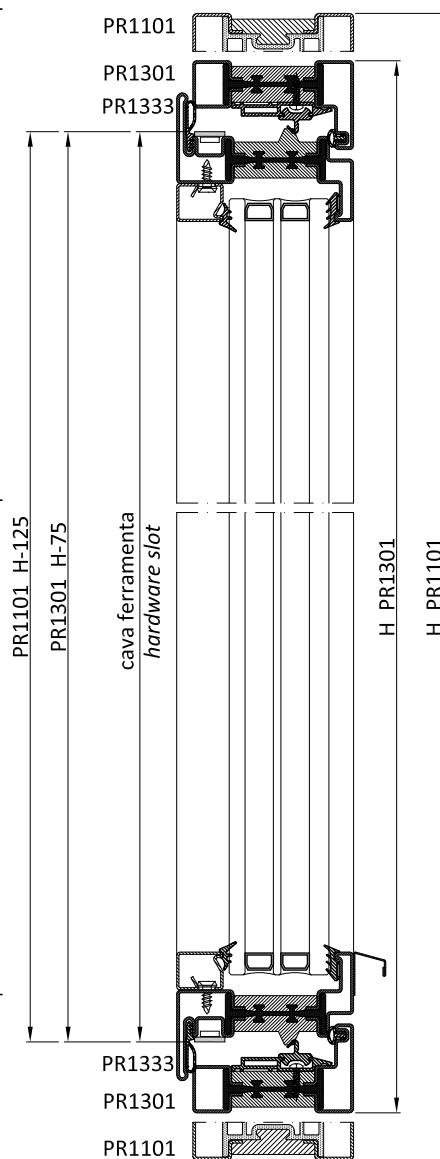
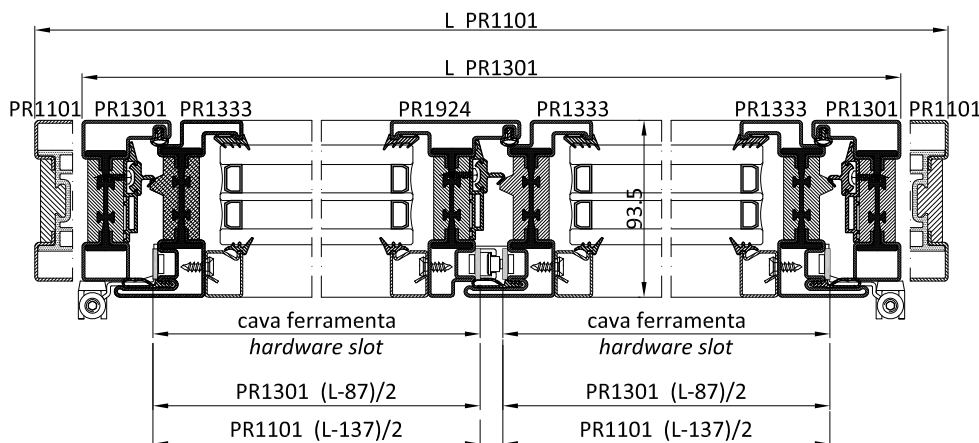
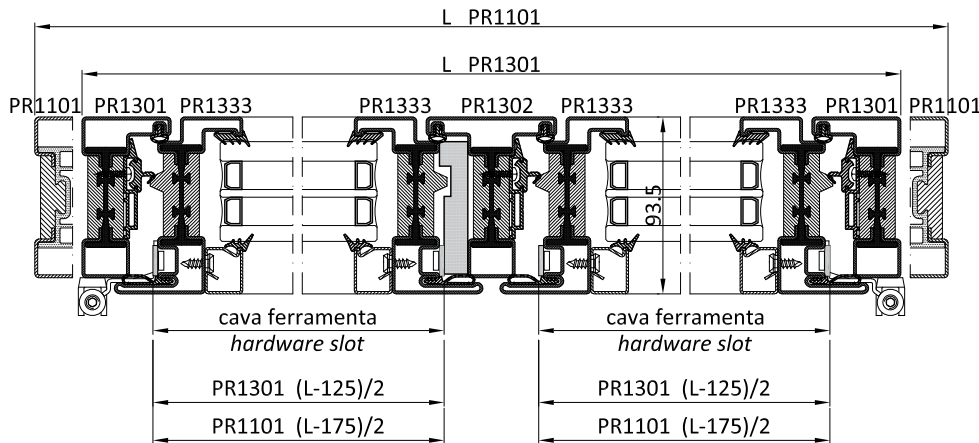
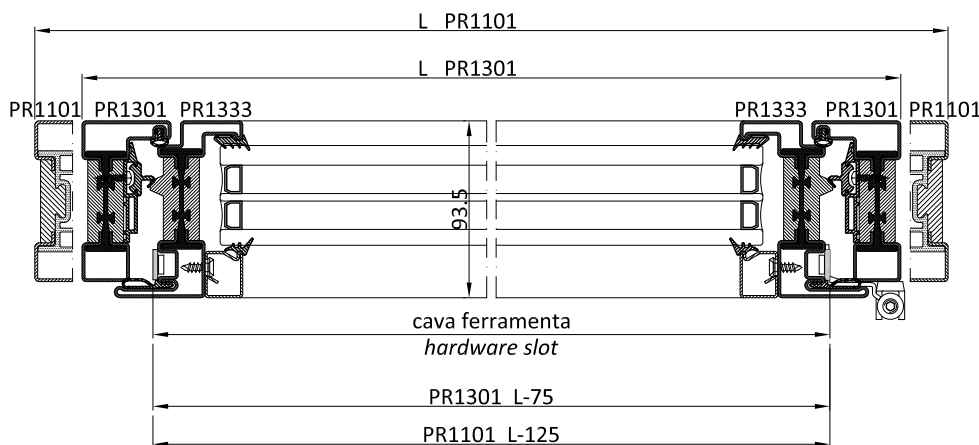

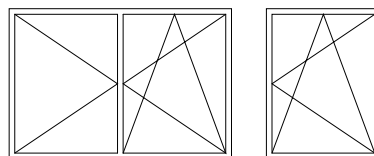

RC2		H altezza - height								
		661 860	861 1000	1001 1200	1201 1400	1401 1600	1601 1800	1801 2000	2001 2200	2201 2400
L larghezza width	601-800	A1	B1	C1	D1	E1	F1	G1	H1	I1
	801-1000	-	B2	C2	D2	E2	F2	G2	H2	I2
	1001-1200	-	-	C3	D3	E3	F3	G3	H3	I3
	1201-1400	-	-	-	D4	E4	-	-	-	-

AG1271-2-5-6	150 kg	RC2
AG1281-2-5-6	130 kg	RC2
AG1291-2-5-6	130 kg	RC2

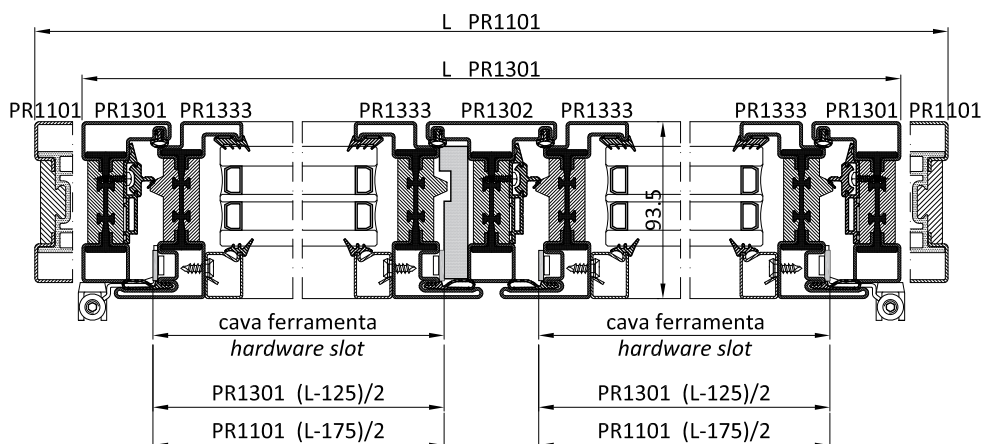
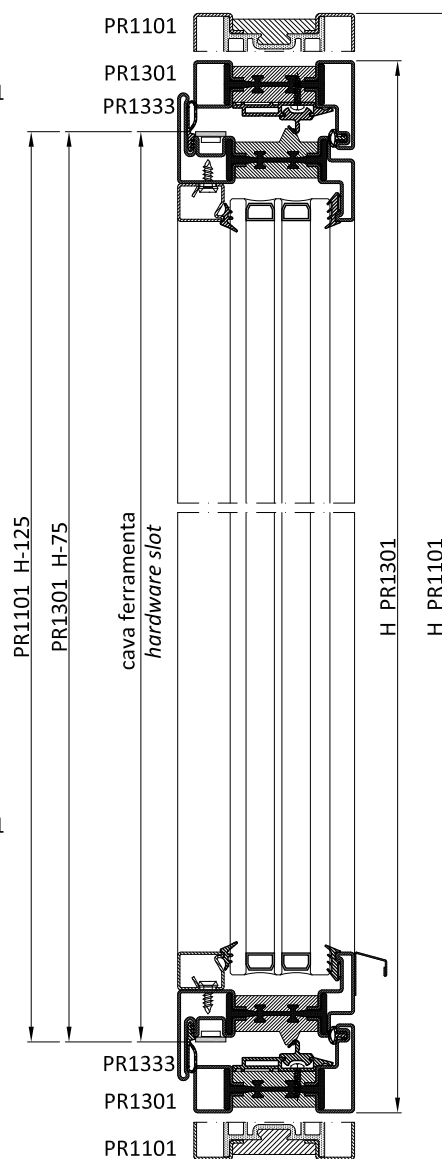
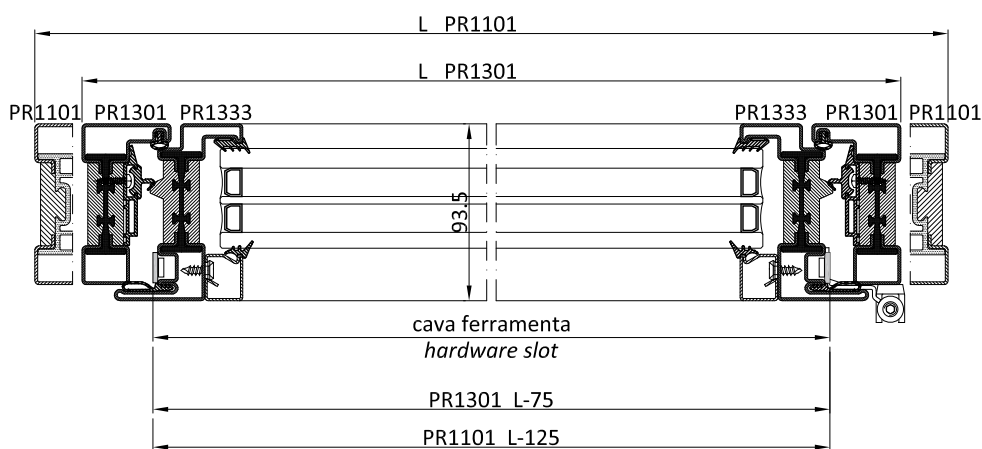

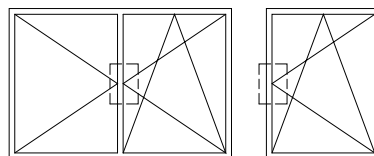

Fori per inserimento quadro comando e fissaggio maniglia / movimento DK
holes for inserting control panel and anchoring of handle / TT (tilt and turn) movement

Asola per inserimento meccanismo cremonese
Slot for insertion of cremone mechanism

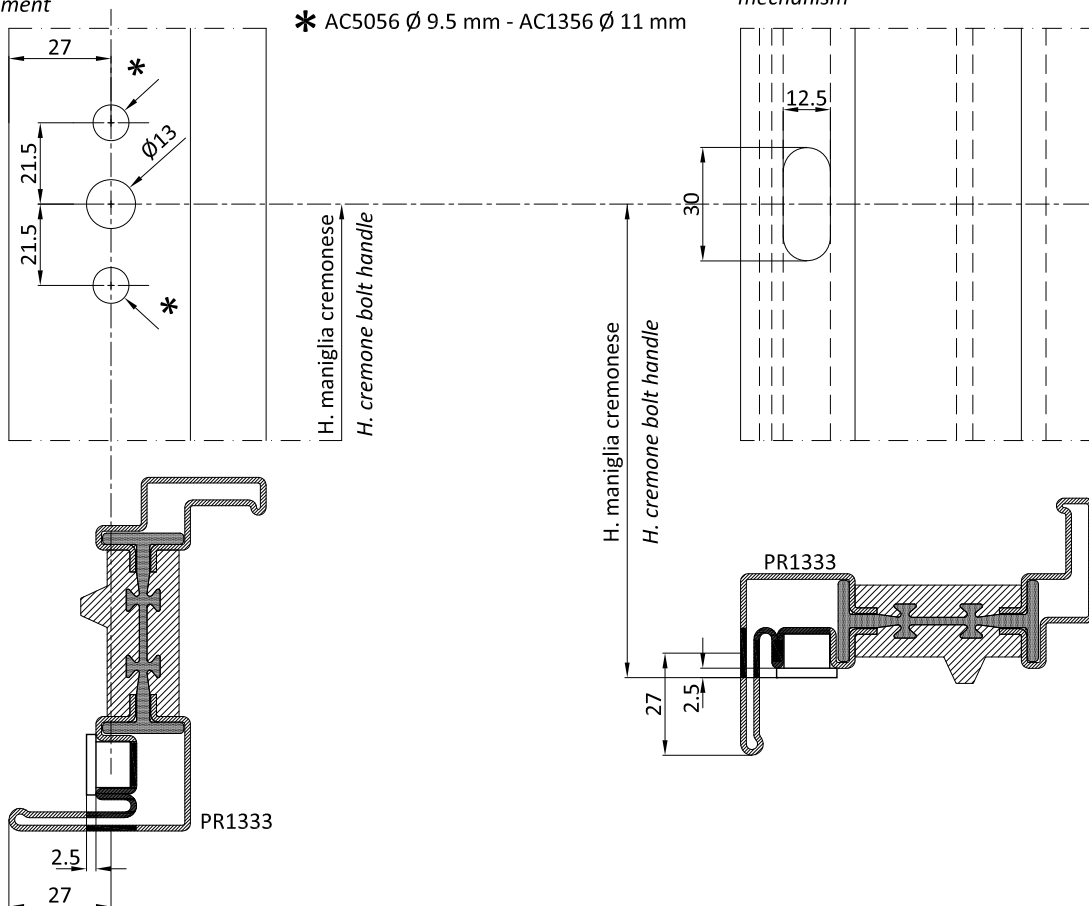

ALTEZZA MANIGLIA CREMONESE - CREMONE BOLT HANDLE HEIGHT			
Tipo Type	H cava ferramenta - H hardware slot Easy - RC2		H maniglia cremonese H cremone bolt handle
Finestre Windows	Y	370 → 520 (No RC2)	H/2
	Z	521 → 660 (No RC2)	H/2
	A	661 → 860	H/2
	B	861 → 1000	H/2
	C	1001 → 1200	500
	D	1201 → 1400	500
	E	1401 → 1600	500
Porte - finestre French Windows	F	1601 → 1800	500
	G	1801 → 2000	1050
	H	2001 → 2200	1050
	I	2201 → 2400	1050
	J	2401 → 2600	1050
	K	2601 → 2800	1050
	L	2801 → 3000	1050

Easy peso massimo anta 150 kg
maximum leaf weight 150 kg

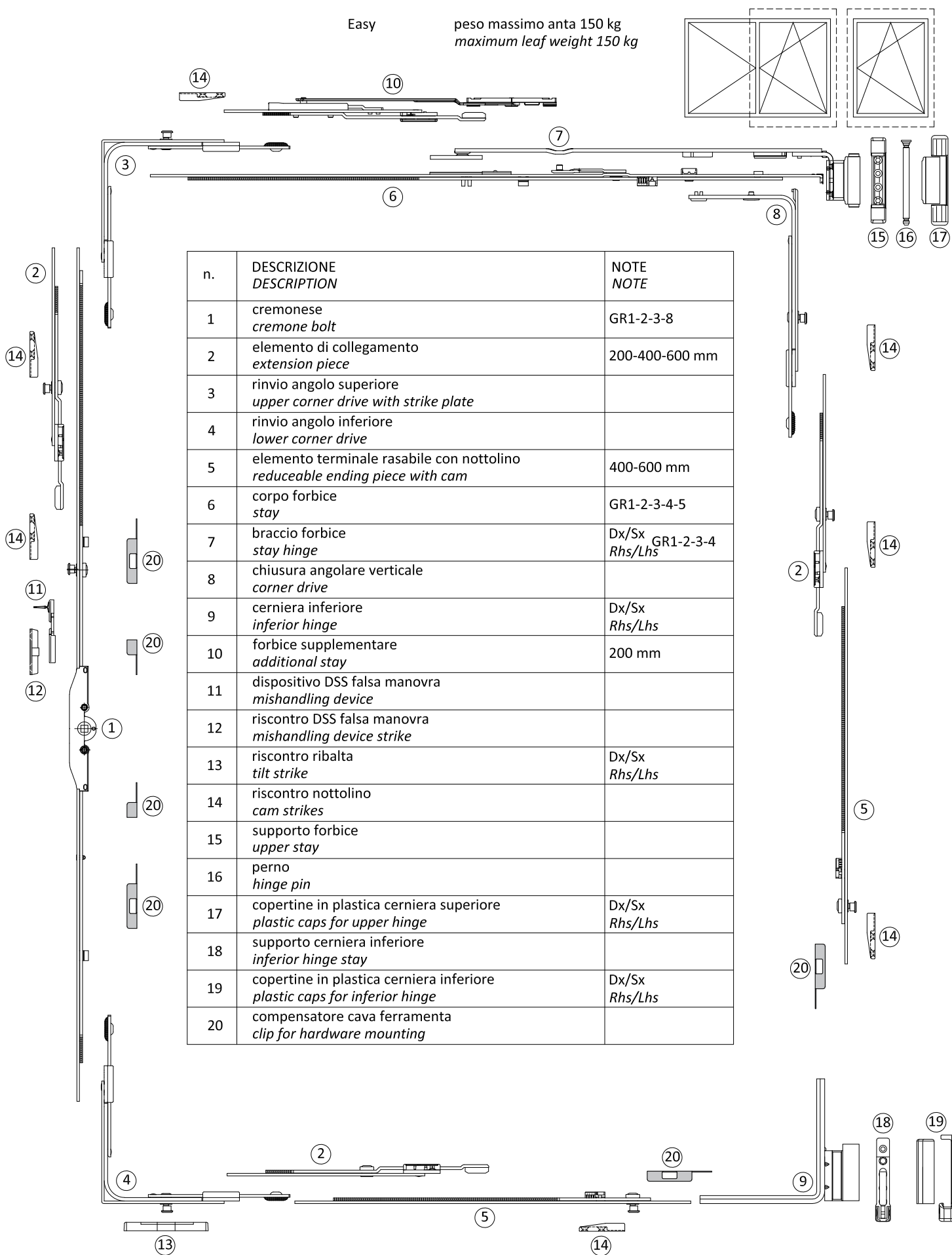

Easy

peso massimo anta 150 kg
maximum leaf weight 150 kg

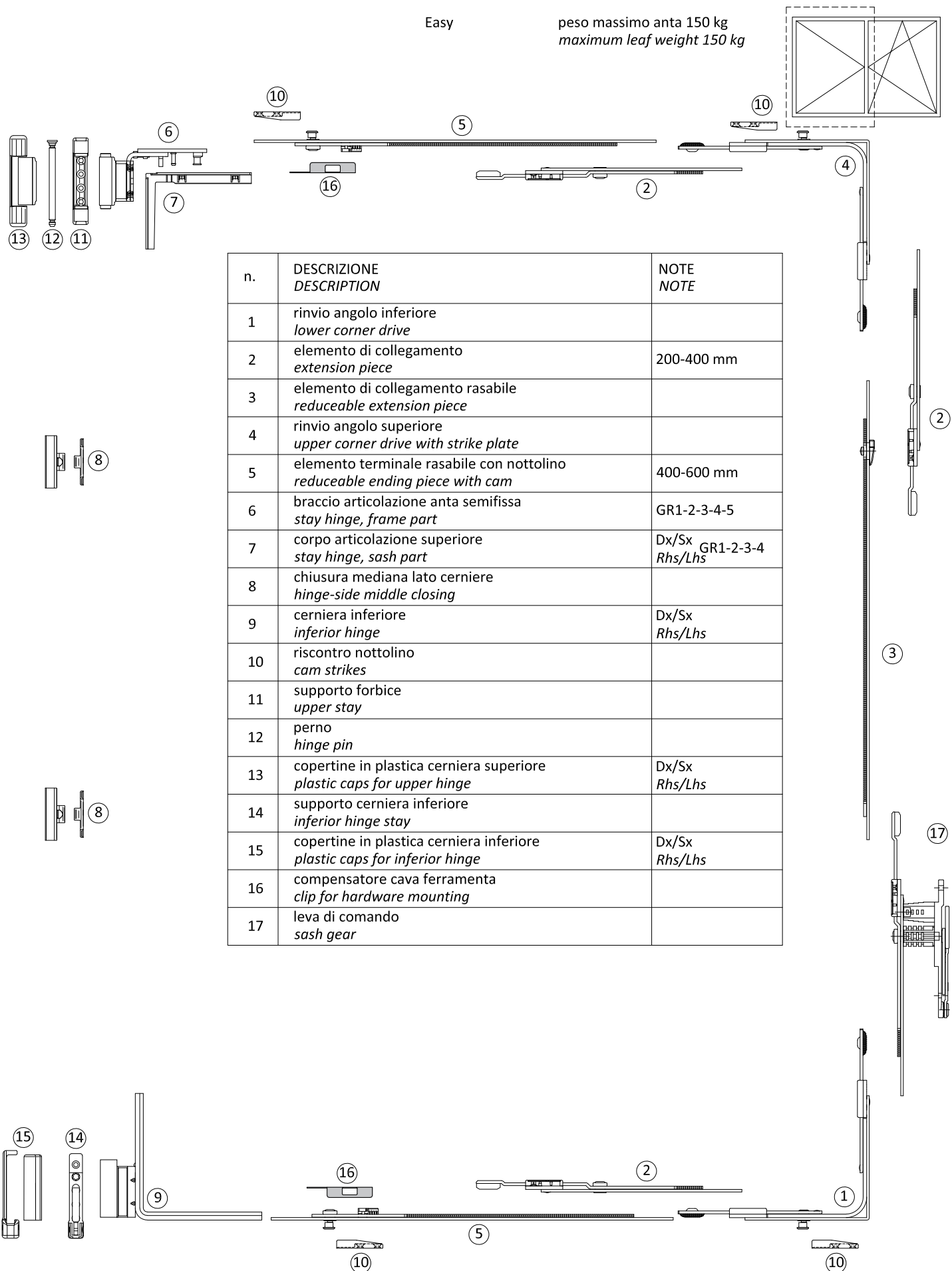

n.	DESCRIZIONE DESCRIPTION	NOTE NOTE
1	rinvio angolo inferiore lower corner drive	
2	elemento di collegamento extension piece	200-400 mm
3	elemento di collegamento rasabile reduceable extension piece	
4	rinvio angolo superiore upper corner drive with strike plate	
5	elemento terminale rasabile con nottolino reduceable ending piece with cam	400-600 mm
6	braccio articolazione anta semifissa stay hinge, frame part	GR1-2-3-4-5
7	corpo articolazione superiore stay hinge, sash part	Dx/Sx GR1-2-3-4 Rhs/Lhs
8	chiusura mediana lato cerniere hinge-side middle closing	
9	cerniera inferiore inferior hinge	Dx/Sx Rhs/Lhs
10	riscontro nottolino cam strikes	
11	supporto forbice upper stay	
12	perno hinge pin	
13	copertine in plastica cerniera superiore plastic caps for upper hinge	Dx/Sx Rhs/Lhs
14	supporto cerniera inferiore inferior hinge stay	
15	copertine in plastica cerniera inferiore plastic caps for inferior hinge	Dx/Sx Rhs/Lhs
16	compensatore cava ferramenta clip for hardware mounting	
17	leva di comando sash gear	

Easy

peso massimo anta 150 kg
maximum leaf weight 150 kg

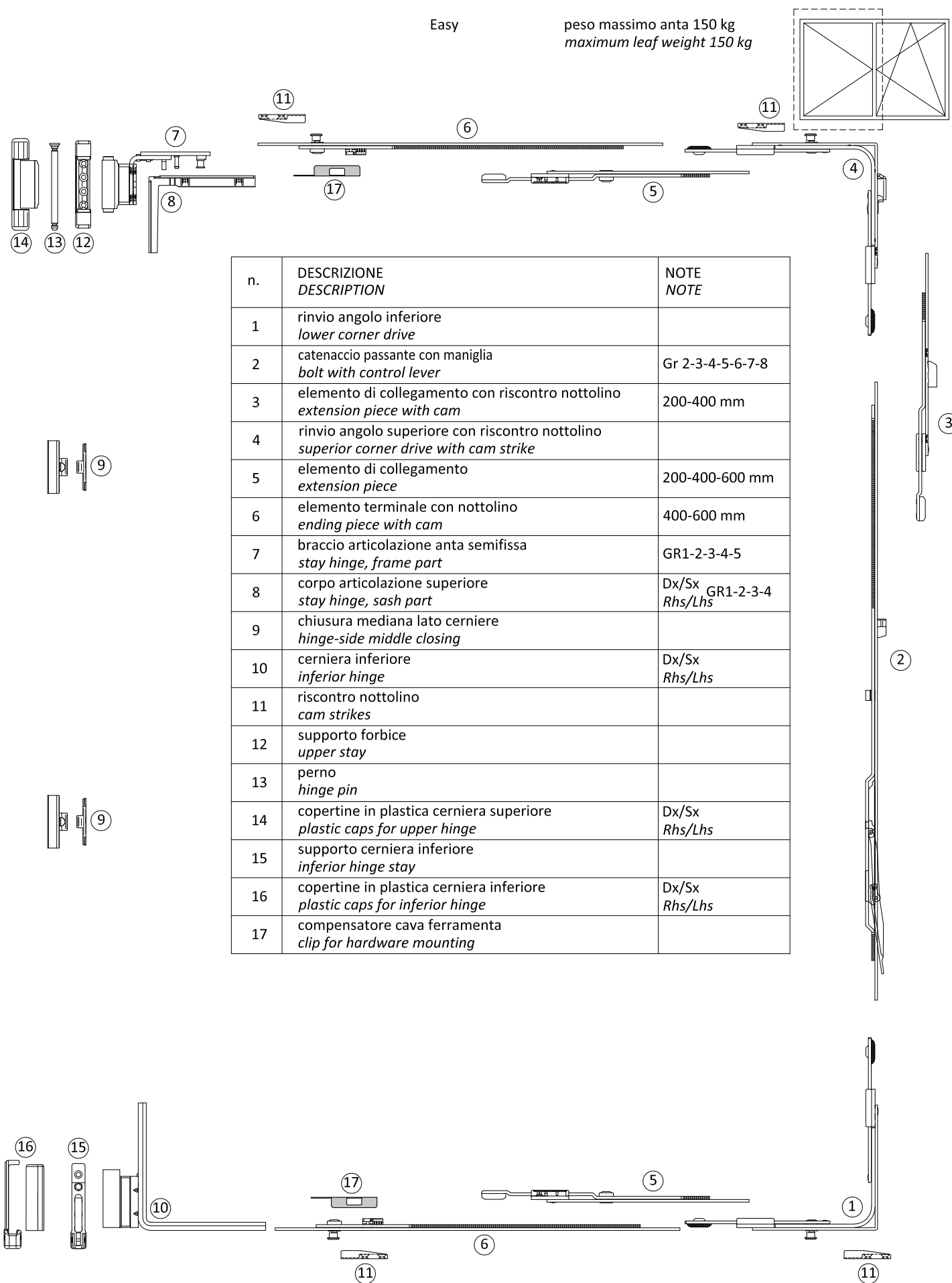

n.	DESCRIZIONE DESCRIPTION	NOTE NOTE
1	rinvio angolo inferiore lower corner drive	
2	catenaccio passante con maniglia bolt with control lever	Gr 2-3-4-5-6-7-8
3	elemento di collegamento con riscontro nottolino extension piece with cam	200-400 mm
4	rinvio angolo superiore con riscontro nottolino superior corner drive with cam strike	
5	elemento di collegamento extension piece	200-400-600 mm
6	elemento terminale con nottolino ending piece with cam	400-600 mm
7	braccio articolazione anta semifissa stay hinge, frame part	GR1-2-3-4-5
8	corpo articolazione superiore stay hinge, sash part	Dx/Sx Rhs/Lhs GR1-2-3-4
9	chiusura mediana lato cerniere hinge-side middle closing	
10	cerniera inferiore inferior hinge	Dx/Sx Rhs/Lhs
11	riscontro nottolino cam strikes	
12	supporto forbice upper stay	
13	perno hinge pin	
14	copertine in plastica cerniera superiore plastic caps for upper hinge	Dx/Sx Rhs/Lhs
15	supporto cerniera inferiore inferior hinge stay	
16	copertine in plastica cerniera inferiore plastic caps for inferior hinge	Dx/Sx Rhs/Lhs
17	compensatore cava ferramenta clip for hardware mounting	

RC2

peso massimo anta 150 kg
maximum leaf weight 150 kg

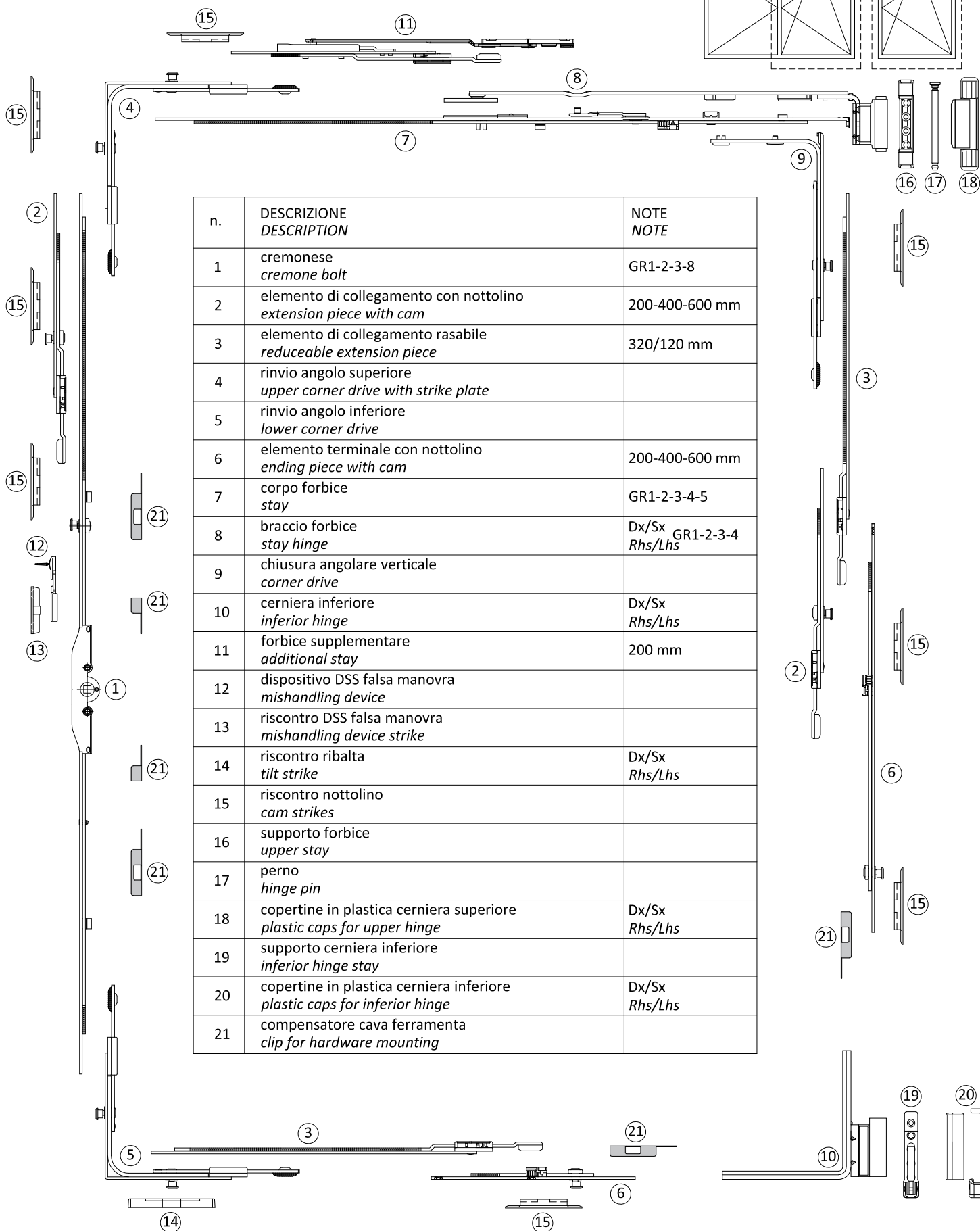
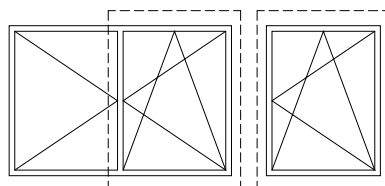

n.	DESCRIZIONE DESCRIPTION	NOTE NOTE
1	cremonese cremone bolt	GR1-2-3-8
2	elemento di collegamento con nottolino extension piece with cam	200-400-600 mm
3	elemento di collegamento rasabile reduceable extension piece	320/120 mm
4	rinvio angolo superiore upper corner drive with strike plate	
5	rinvio angolo inferiore lower corner drive	
6	elemento terminale con nottolino ending piece with cam	200-400-600 mm
7	corpo forbice stay	GR1-2-3-4-5
8	braccio forbice stay hinge	Dx/Sx GR1-2-3-4 Rhs/Lhs
9	chiusura angolare verticale corner drive	
10	cerniera inferiore inferior hinge	Dx/Sx Rhs/Lhs
11	forbice supplementare additional stay	200 mm
12	dispositivo DSS falsa manovra mishandling device	
13	riscontro DSS falsa manovra mishandling device strike	
14	riscontro ribalta tilt strike	Dx/Sx Rhs/Lhs
15	riscontro nottolino cam strikes	
16	supporto forbice upper stay	
17	perno hinge pin	
18	copertine in plastica cerniera superiore plastic caps for upper hinge	Dx/Sx Rhs/Lhs
19	supporto cerniera inferiore inferior hinge stay	
20	copertine in plastica cerniera inferiore plastic caps for inferior hinge	Dx/Sx Rhs/Lhs
21	compensatore cava ferramenta clip for hardware mounting	

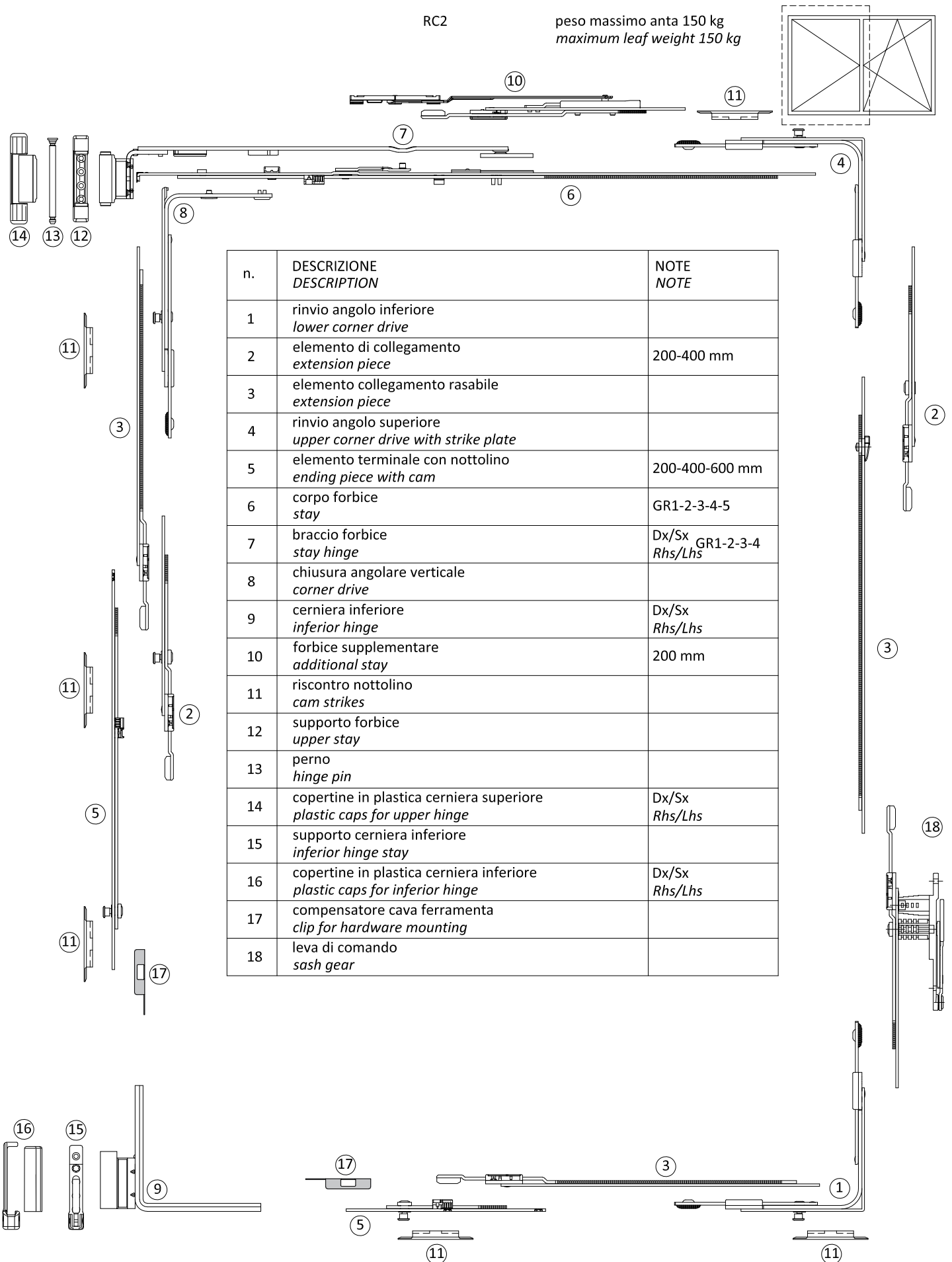

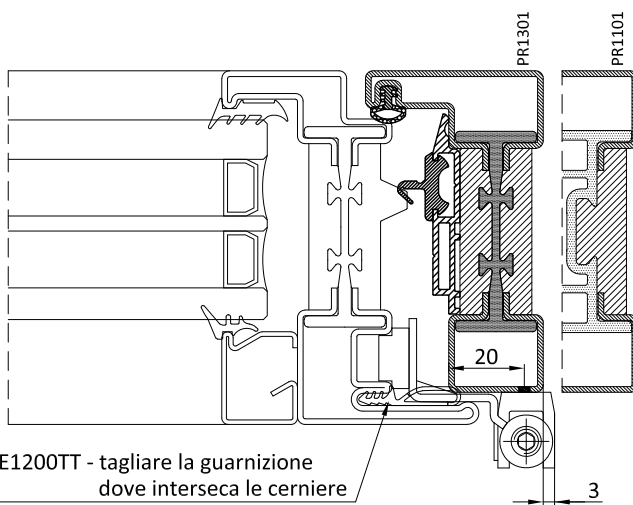
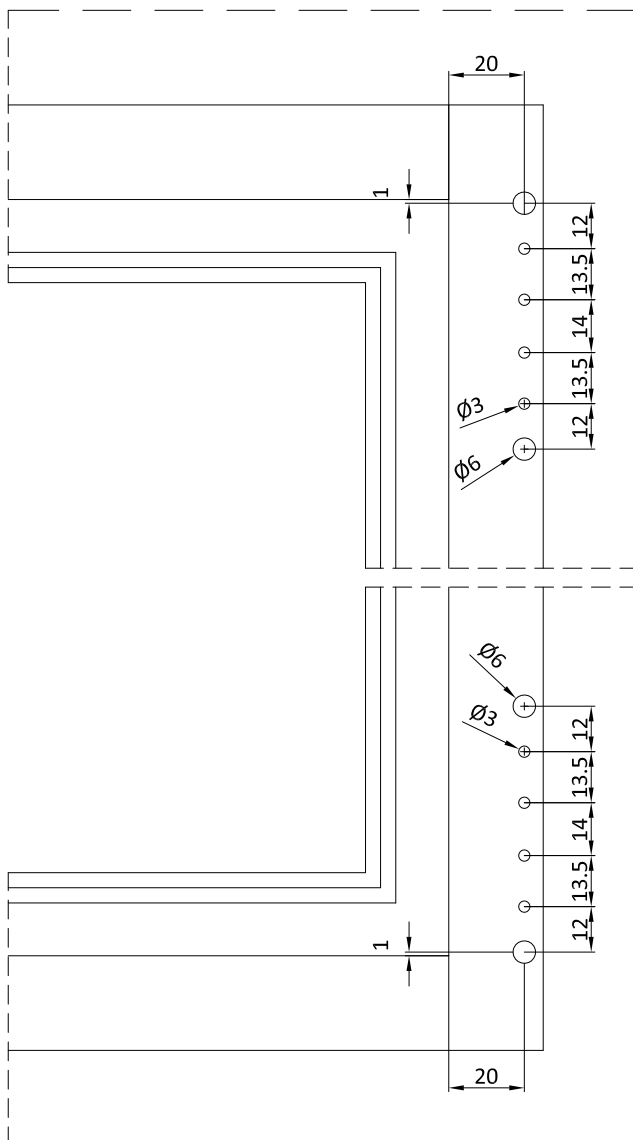
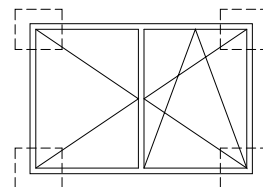

GE1200TT - tagliare la guarnizione dove interseca le cerniere
GE1200TT - cut the gasket where the hinges cross

Fori eseguibili con maschera ATG271
Holes to be done with ATG271



Easy peso massimo anta 130 kg
maximum leaf weight 130 kg

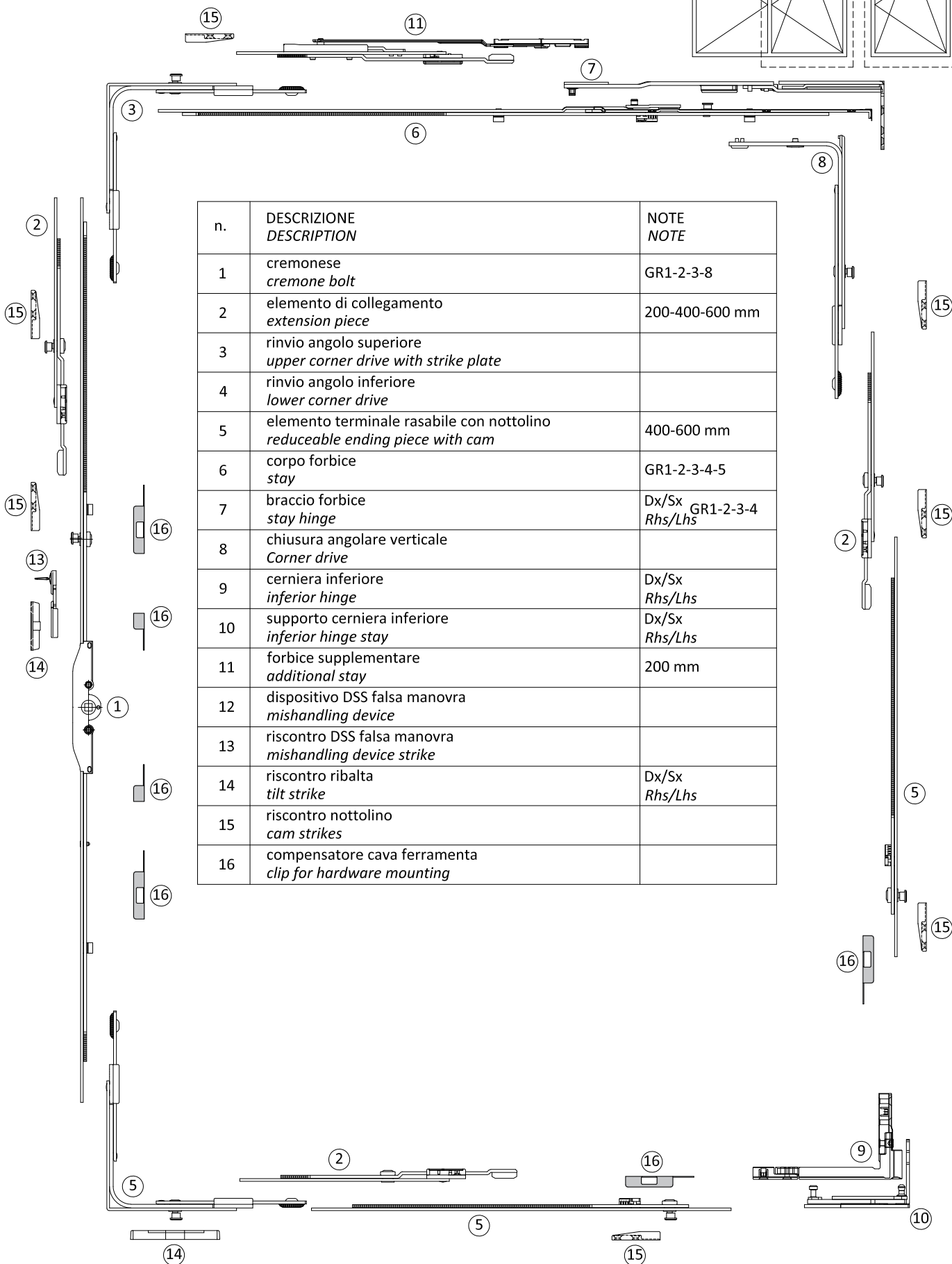
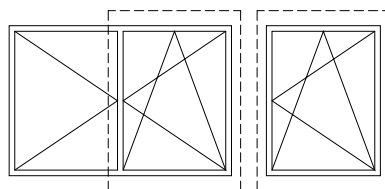

Easy

peso massimo anta 130 kg
maximum leaf weight 130 kg

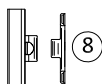
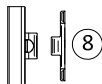
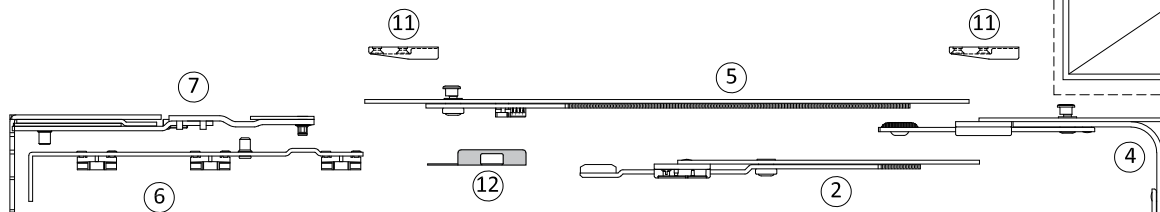
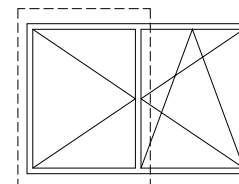

n.	DESCRIZIONE DESCRIPTION	NOTE NOTE
1	rinvio angolo inferiore lower corner drive	
2	elemento di collegamento extension piece	200-400 mm
3	elemento di collegamento rasabile reduceable extension piece	Gr 1-2-3-8
4	rinvio angolo superiore upper corner drive with strike plate	
5	elemento terminale con nottolino ending piece with cam	400-600 mm
6	corpo forbice stay	GR1-2-3-4-5
7	braccio forbice stay hinge	Ds/Sx L/R GR1-2-3-4
8	chiusura mediana lato cerniere hinge-side middle closing	
9	cerniera inferiore inferior hinge	Ds/Sx L/R
10	supporto cerniera inferiore inferior hinge stay	Ds/Sx L/R
11	riscontro nottolino cam strikes	
12	compensatore cava ferramenta clip for hardware mounting	
13	leva di comando sash gear	

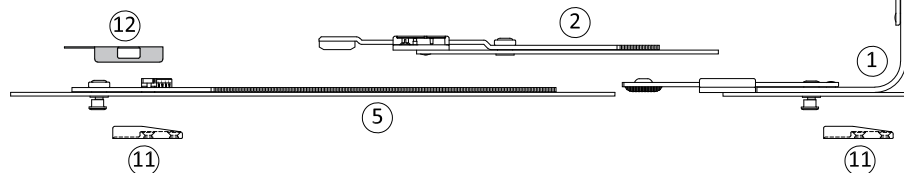
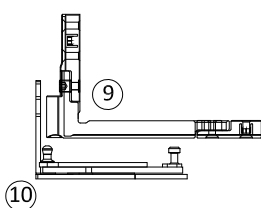
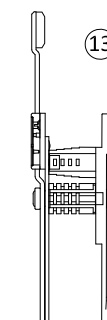
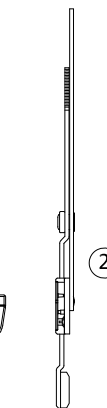

Easy

peso massimo anta 130 kg
maximum leaf weight 130 kg

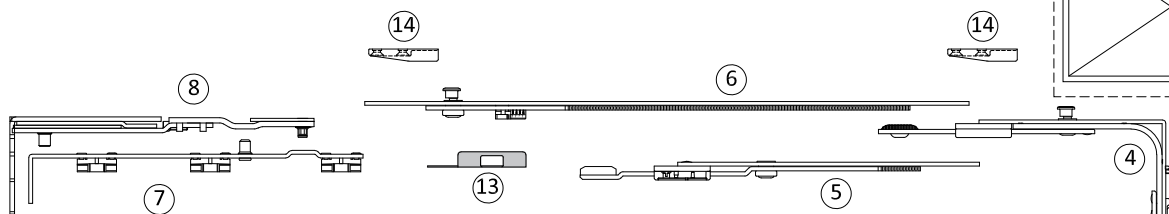
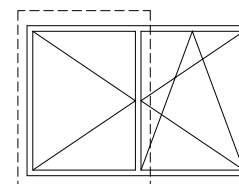

n.	DESCRIZIONE DESCRIPTION	NOTE NOTE
1	rinvio angolo inferiore lower corner drive	
2	catenaccio passante con maniglia bolt with control lever	Gr 2-3-4-5-6-7-8
3	elemento di collegamento con riscontro nottolino extension piece with cam	200-400 mm
4	rinvio angolo superiore con riscontro nottolino superior corner drive with cam strike	
5	elemento di collegamento extension piece	200-400-600 mm
6	elemento terminale con nottolino ending piece with cam	400-600 mm
7	corpo forbice stay	GR1-2-3-4-5
8	braccio forbice stay hinge	Ds/Sx L/R GR1-2-3-4
9	chiusura mediana lato cerniere hinge-side middle closing	
10	cerniera inferiore inferior hinge	Ds/Sx L/R
11	supporto cerniera inferiore inferior hinge stay	Ds/Sx L/R
12	riscontro nottolino cam strikes	
13	compensatore cava ferramenta clip for hardware mounting	

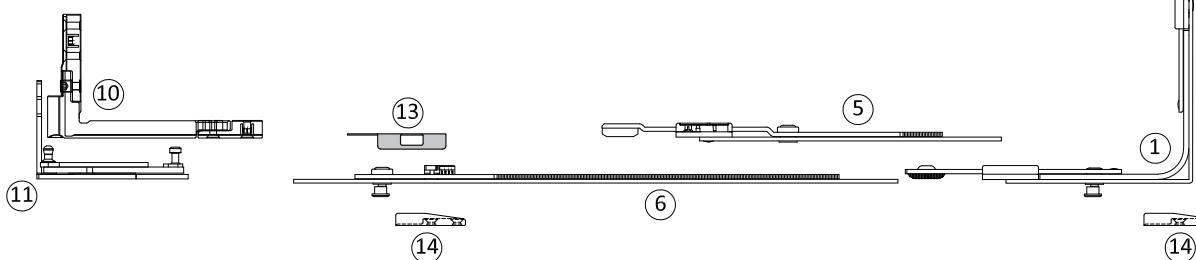
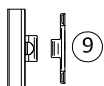
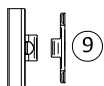

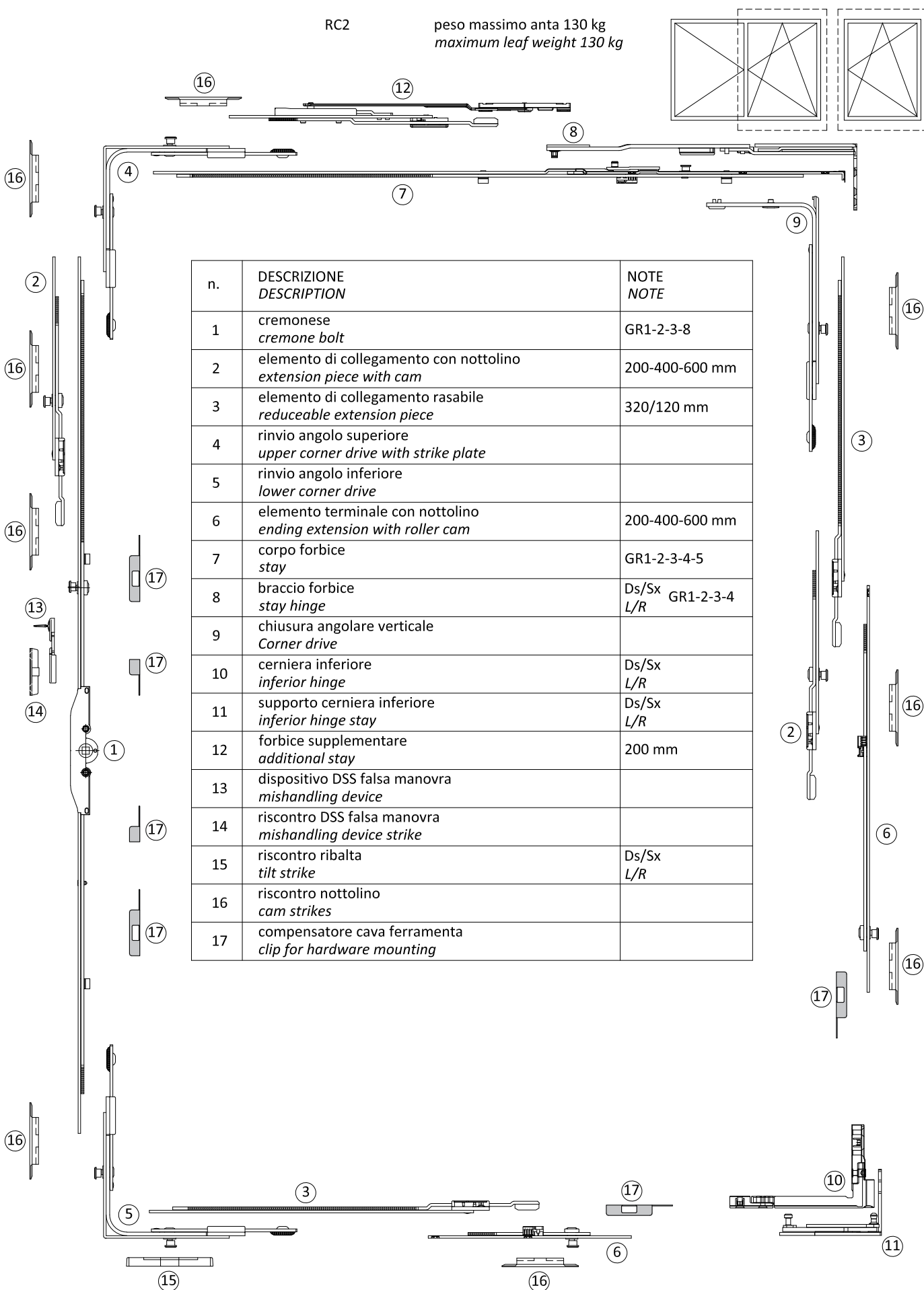

RC2

peso massimo anta 130 kg
maximum leaf weight 130 kg

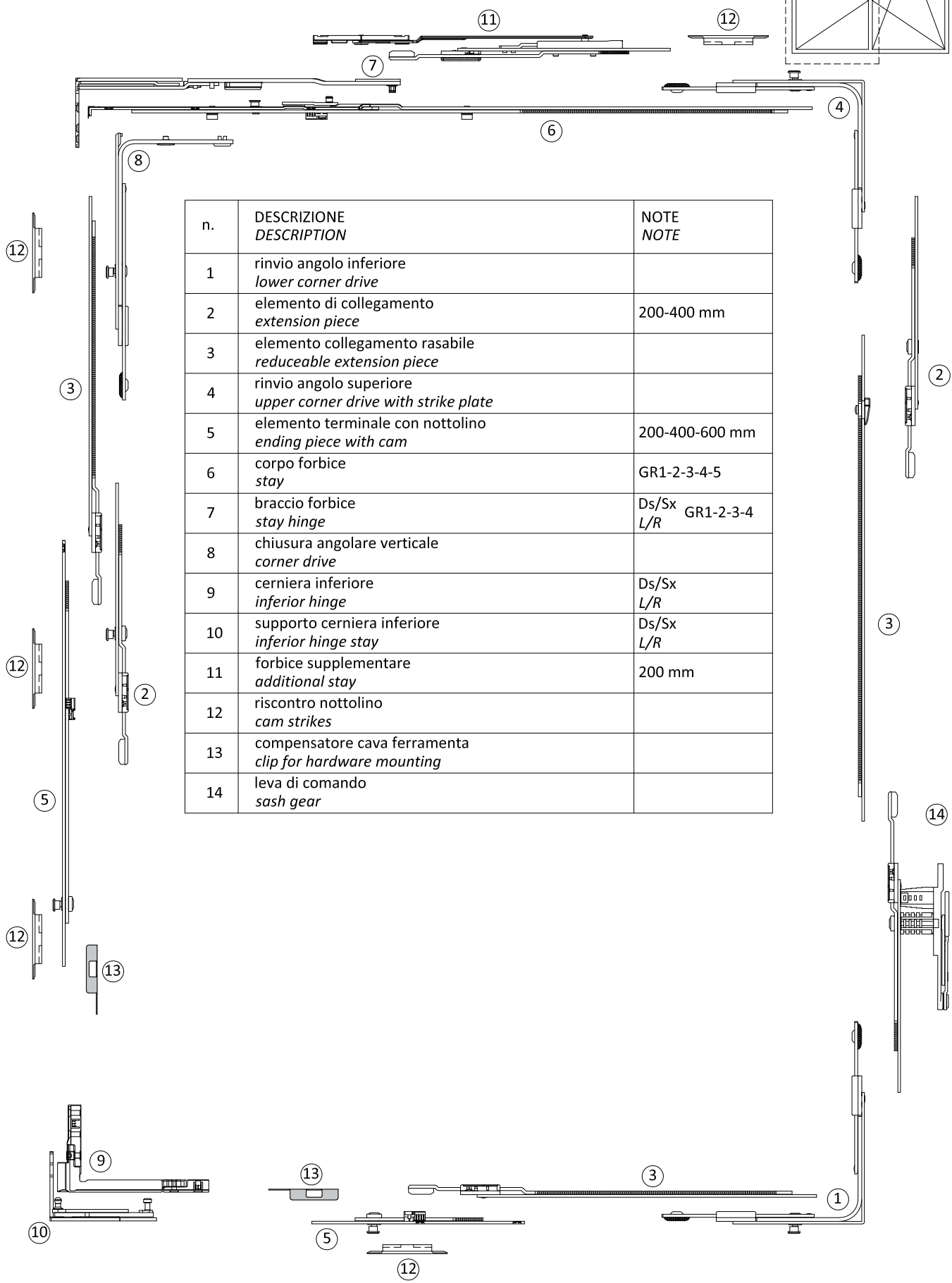
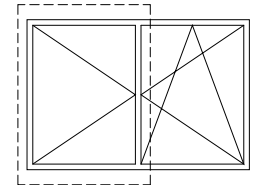

n.	DESCRIZIONE DESCRIPTION	NOTE NOTE
1	rinvio angolo inferiore lower corner drive	
2	elemento di collegamento extension piece	200-400 mm
3	elemento collegamento rasabile reduceable extension piece	
4	rinvio angolo superiore upper corner drive with strike plate	
5	elemento terminale con nottolino ending piece with cam	200-400-600 mm
6	corpo forbice stay	GR1-2-3-4-5
7	braccio forbice stay hinge	Ds/Sx L/R GR1-2-3-4
8	chiusura angolare verticale corner drive	
9	cerniera inferiore inferior hinge	Ds/Sx L/R
10	supporto cerniera inferiore inferior hinge stay	Ds/Sx L/R
11	forbice supplementare additional stay	200 mm
12	riscontro nottolino cam strikes	
13	compensatore cava ferramenta clip for hardware mounting	
14	leva di comando sash gear	

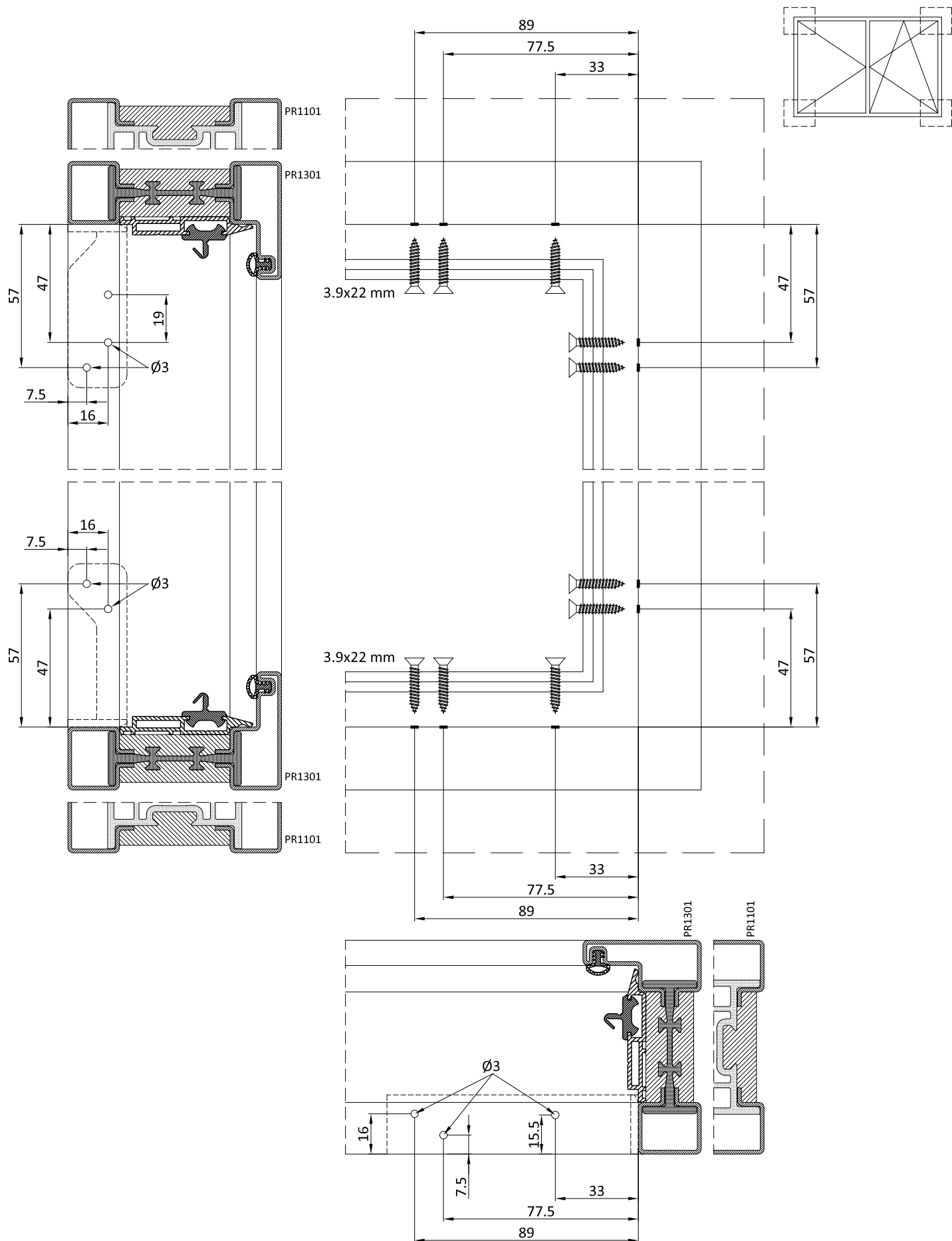

Fori eseguibili con maschera ATG281
Holes to be done with ATG281



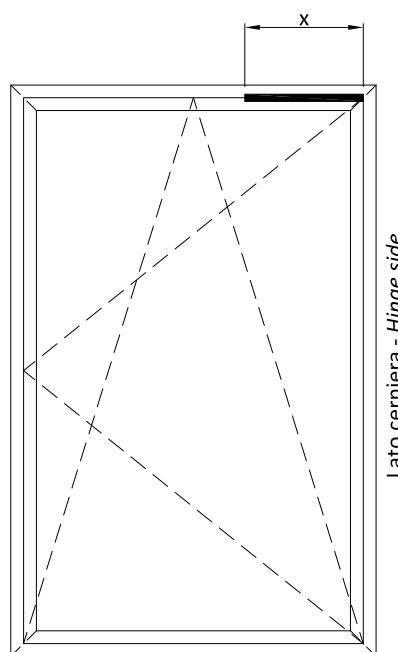
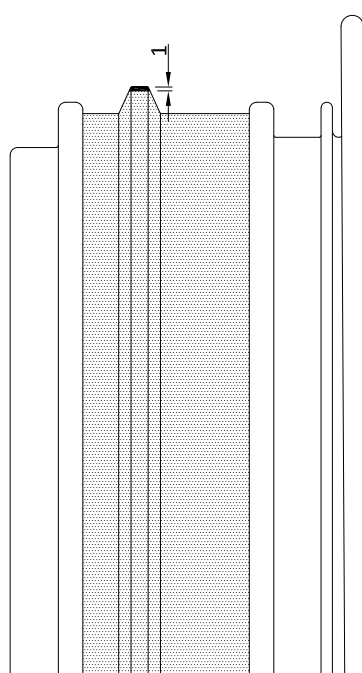
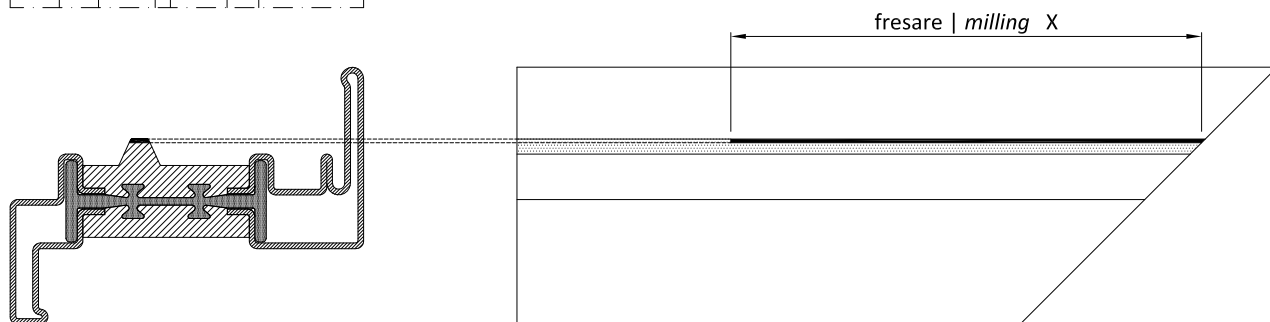
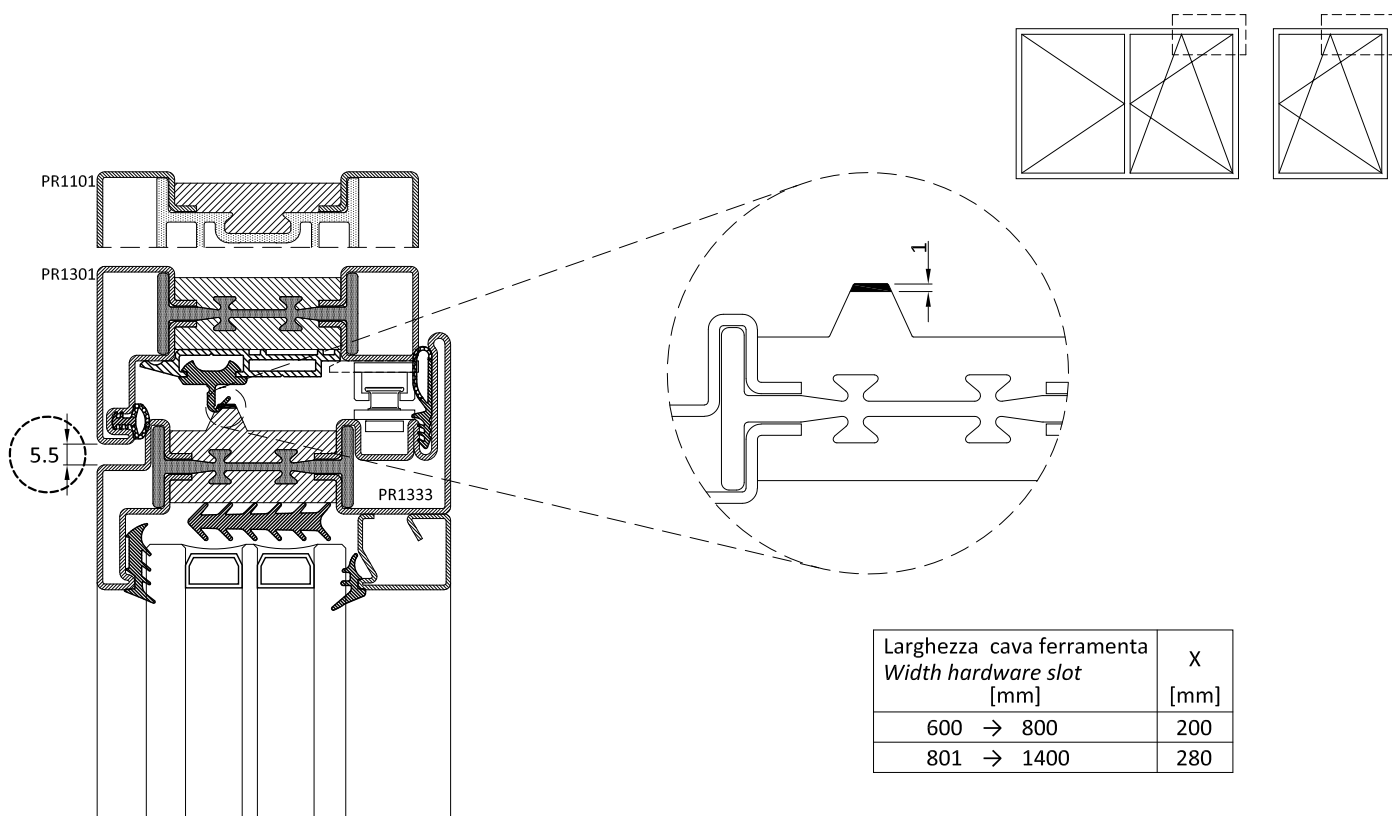

Easy peso massimo anta 130 kg
maximum leaf weight 130 kg

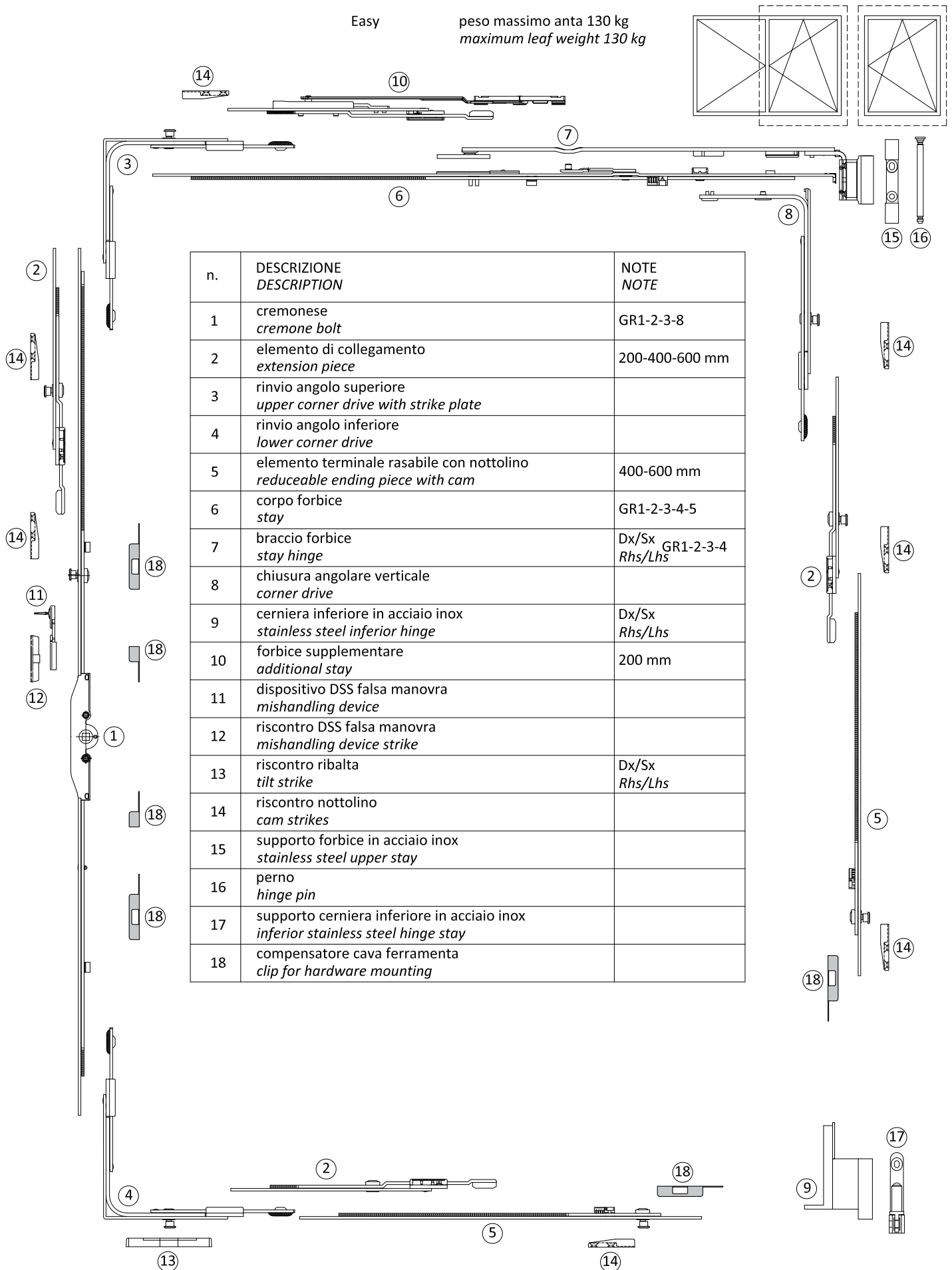

Easy

peso massimo anta 130 kg
maximum leaf weight 130 kg

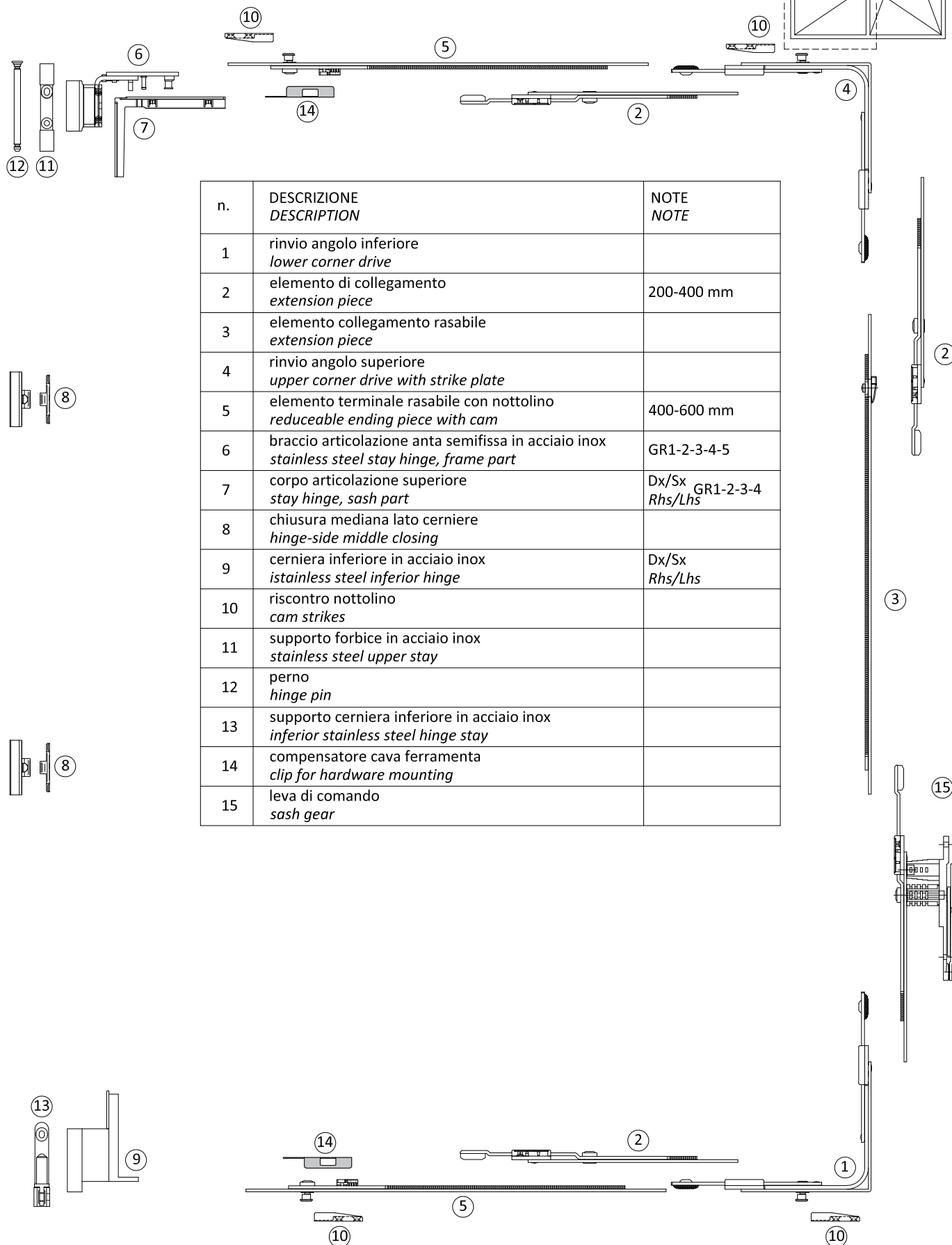
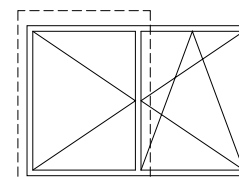

n.	DESCRIZIONE DESCRIPTION	NOTE NOTE
1	rinvio angolo inferiore <i>lower corner drive</i>	
2	elemento di collegamento <i>extension piece</i>	200-400 mm
3	elemento collegamento rasabile <i>extension piece</i>	
4	rinvio angolo superiore <i>upper corner drive with strike plate</i>	
5	elemento terminale rasabile con nottolino <i>reduceable ending piece with cam</i>	400-600 mm
6	braccio articolazione anta semifissa in acciaio inox <i>stainless steel stay hinge, frame part</i>	GR1-2-3-4-5
7	corpo articolazione superiore <i>stay hinge, sash part</i>	Dx/Sx GR1-2-3-4 Rhs/Lhs
8	chiusura mediana lato cerniere <i>hinge-side middle closing</i>	
9	cerniera inferiore in acciaio inox <i>stainless steel inferior hinge</i>	Dx/Sx Rhs/Lhs
10	riscontro nottolino <i>cam strikes</i>	
11	supporto forbice in acciaio inox <i>stainless steel upper stay</i>	
12	perno <i>hinge pin</i>	
13	supporto cerniera inferiore in acciaio inox <i>inferior stainless steel hinge stay</i>	
14	compensatore cava ferramenta <i>clip for hardware mounting</i>	
15	leva di comando <i>sash gear</i>	

Easy

peso massimo anta 130 kg
maximum leaf weight 130 kg

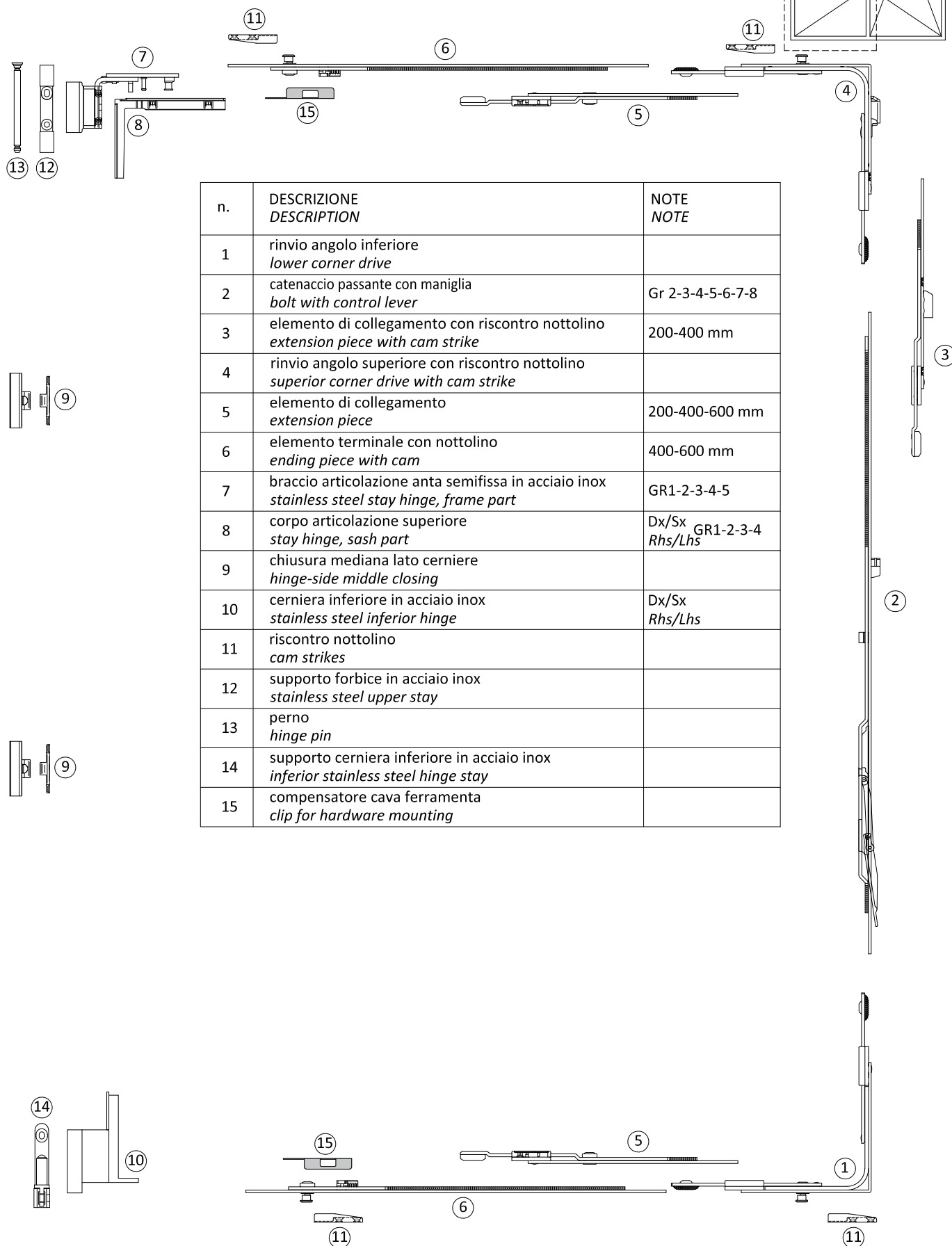
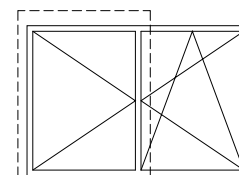

n.	DESCRIZIONE DESCRIPTION	NOTE NOTE
1	rinvio angolo inferiore lower corner drive	
2	catenaccio passante con maniglia bolt with control lever	Gr 2-3-4-5-6-7-8
3	elemento di collegamento con riscontro nottolino extension piece with cam strike	200-400 mm
4	rinvio angolo superiore con riscontro nottolino superior corner drive with cam strike	
5	elemento di collegamento extension piece	200-400-600 mm
6	elemento terminale con nottolino ending piece with cam	400-600 mm
7	braccio articolazione anta semifissa in acciaio inox stainless steel stay hinge, frame part	GR1-2-3-4-5
8	corpo articolazione superiore stay hinge, sash part	Dx/Sx GR1-2-3-4 Rhs/Lhs
9	chiusura mediana lato cerniere hinge-side middle closing	
10	cerniera inferiore in acciaio inox stainless steel inferior hinge	Dx/Sx Rhs/Lhs
11	riscontro nottolino cam strikes	
12	supporto forbice in acciaio inox stainless steel upper stay	
13	perno hinge pin	
14	supporto cerniera inferiore in acciaio inox inferior stainless steel hinge stay	
15	compensatore cava ferramenta clip for hardware mounting	

RC2

peso massimo anta 130 kg
maximum leaf weight 130 kg

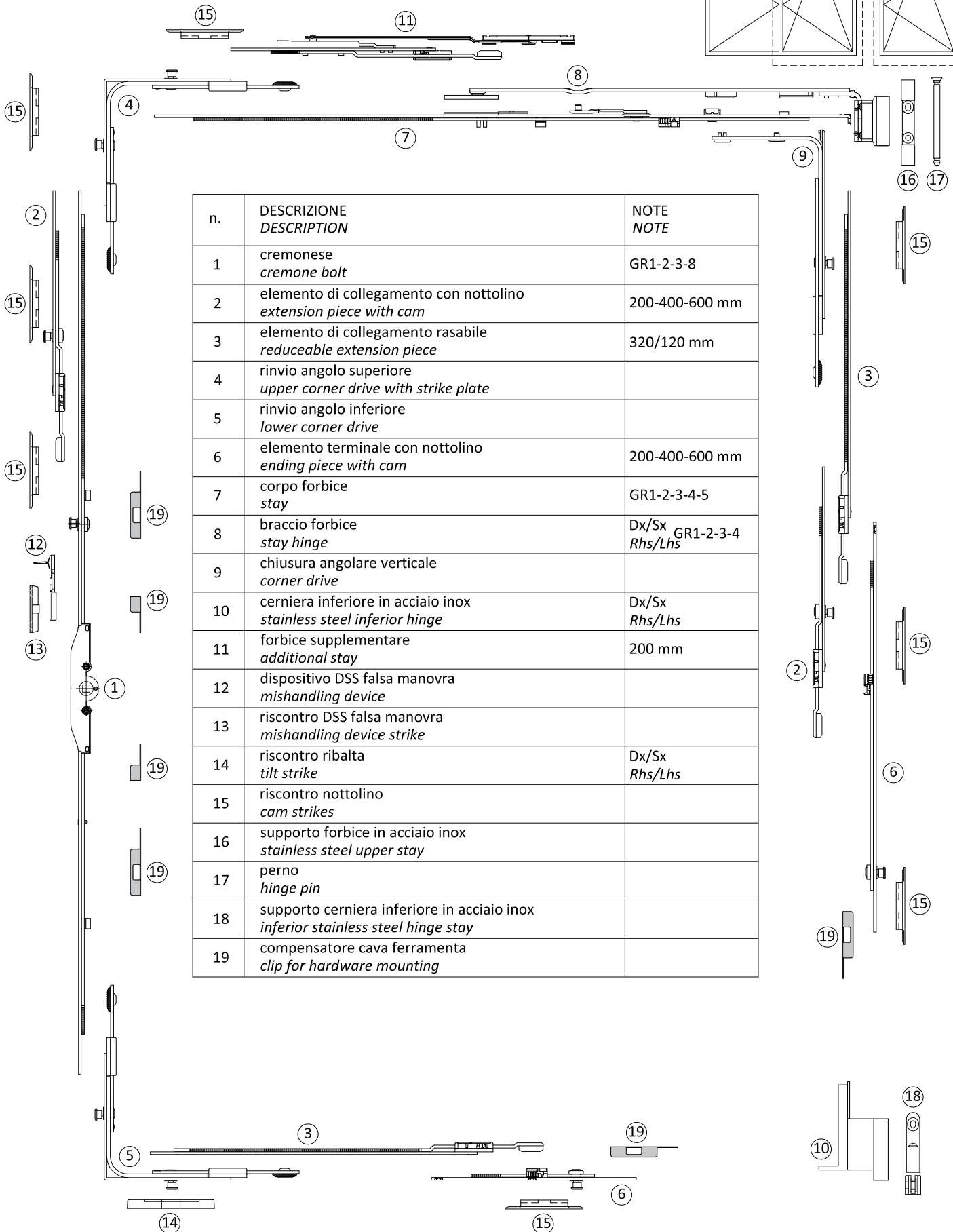
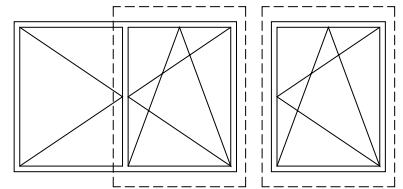

n.	DESCRIZIONE DESCRIPTION	NOTE NOTE
1	cremonese cremone bolt	GR1-2-3-8
2	elemento di collegamento con nottolino extension piece with cam	200-400-600 mm
3	elemento di collegamento rasabile reduceable extension piece	320/120 mm
4	rinvio angolo superiore upper corner drive with strike plate	
5	rinvio angolo inferiore lower corner drive	
6	elemento terminale con nottolino ending piece with cam	200-400-600 mm
7	corpo forbice stay	GR1-2-3-4-5
8	braccio forbice stay hinge	Dx/Sx GR1-2-3-4 Rhs/Lhs
9	chiusura angolare verticale corner drive	
10	cerniera inferiore in acciaio inox stainless steel inferior hinge	Dx/Sx Rhs/Lhs
11	forbice supplementare additional stay	200 mm
12	dispositivo DSS falsa manovra mishandling device	
13	riscontro DSS falsa manovra mishandling device strike	
14	riscontro ribalta tilt strike	Dx/Sx Rhs/Lhs
15	riscontro nottolino cam strikes	
16	supporto forbice in acciaio inox stainless steel upper stay	
17	perno hinge pin	
18	supporto cerniera inferiore in acciaio inox inferior stainless steel hinge stay	
19	compensatore cava ferramenta clip for hardware mounting	

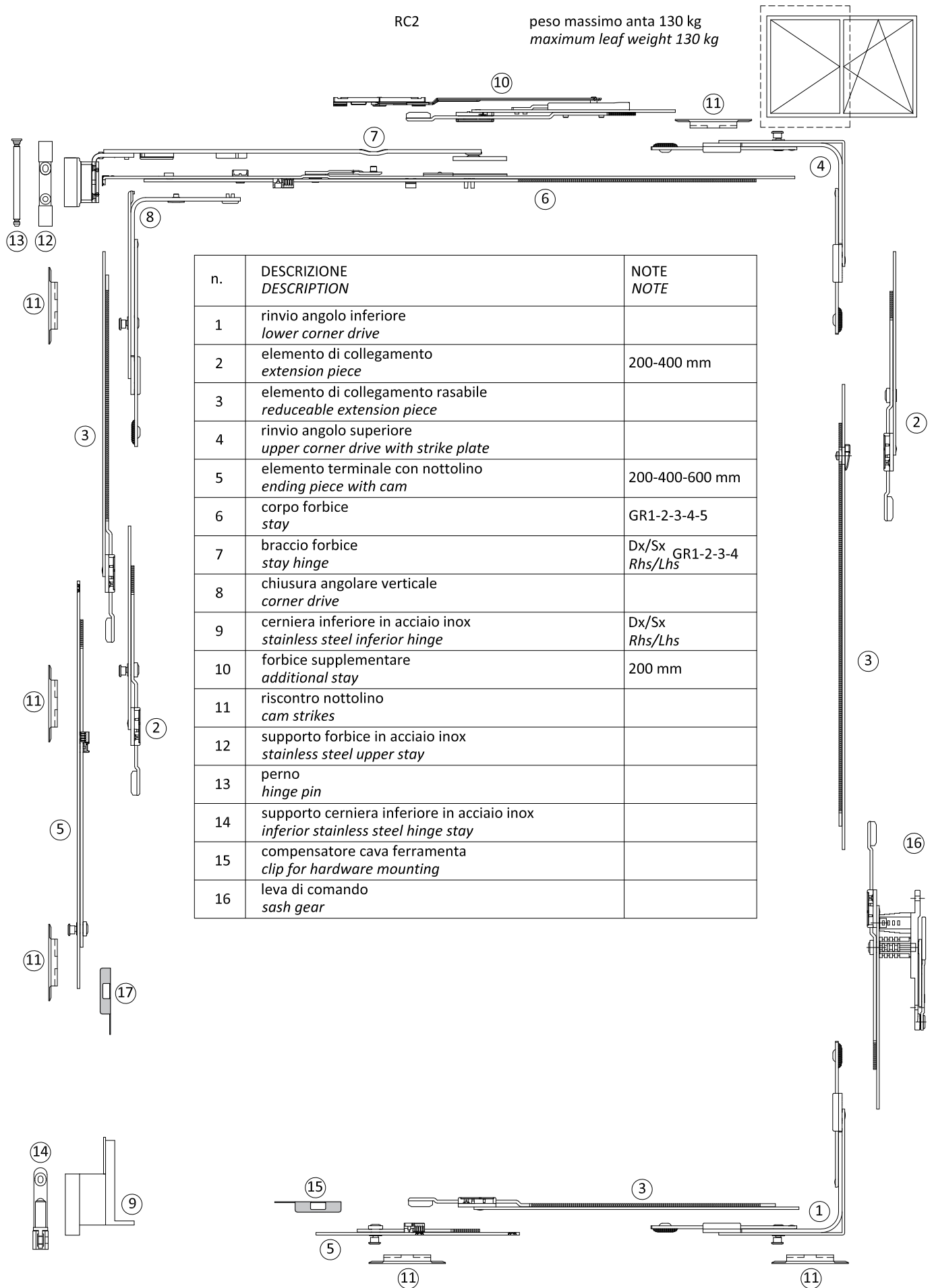

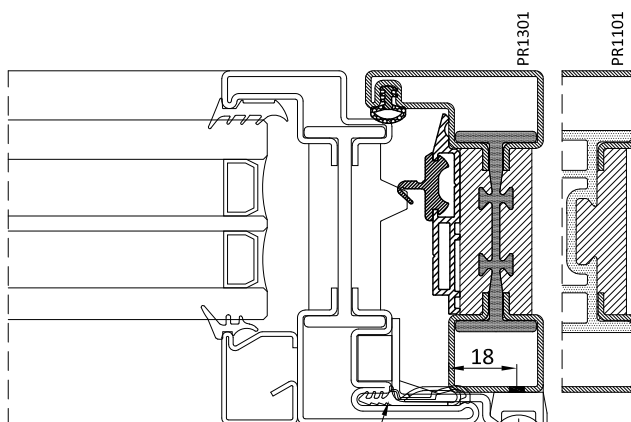
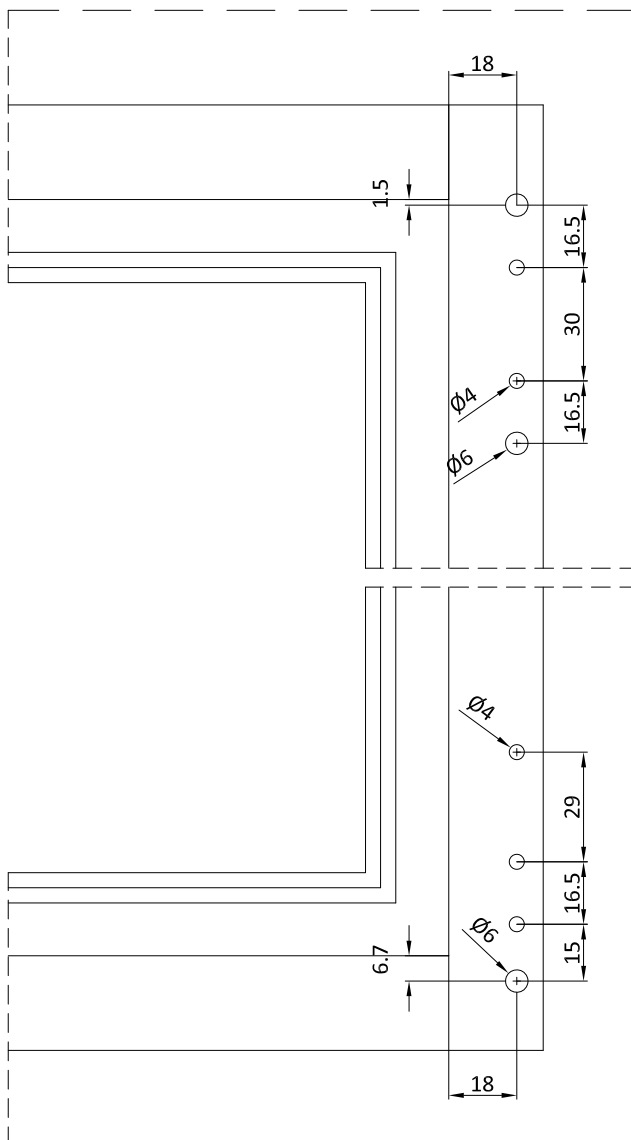
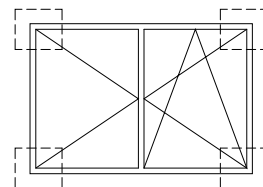

GE1200TT - tagliare la guarnizione dove interseca le cerniere
GE1200TT - cut the gasket where the hinges cross

Fori eseguibili con maschera AT1242
Holes to be done with AT1242



Easy

peso massimo anta 180 kg
(AC1237)
maximum leaf weight 180 kg
(AC1237)

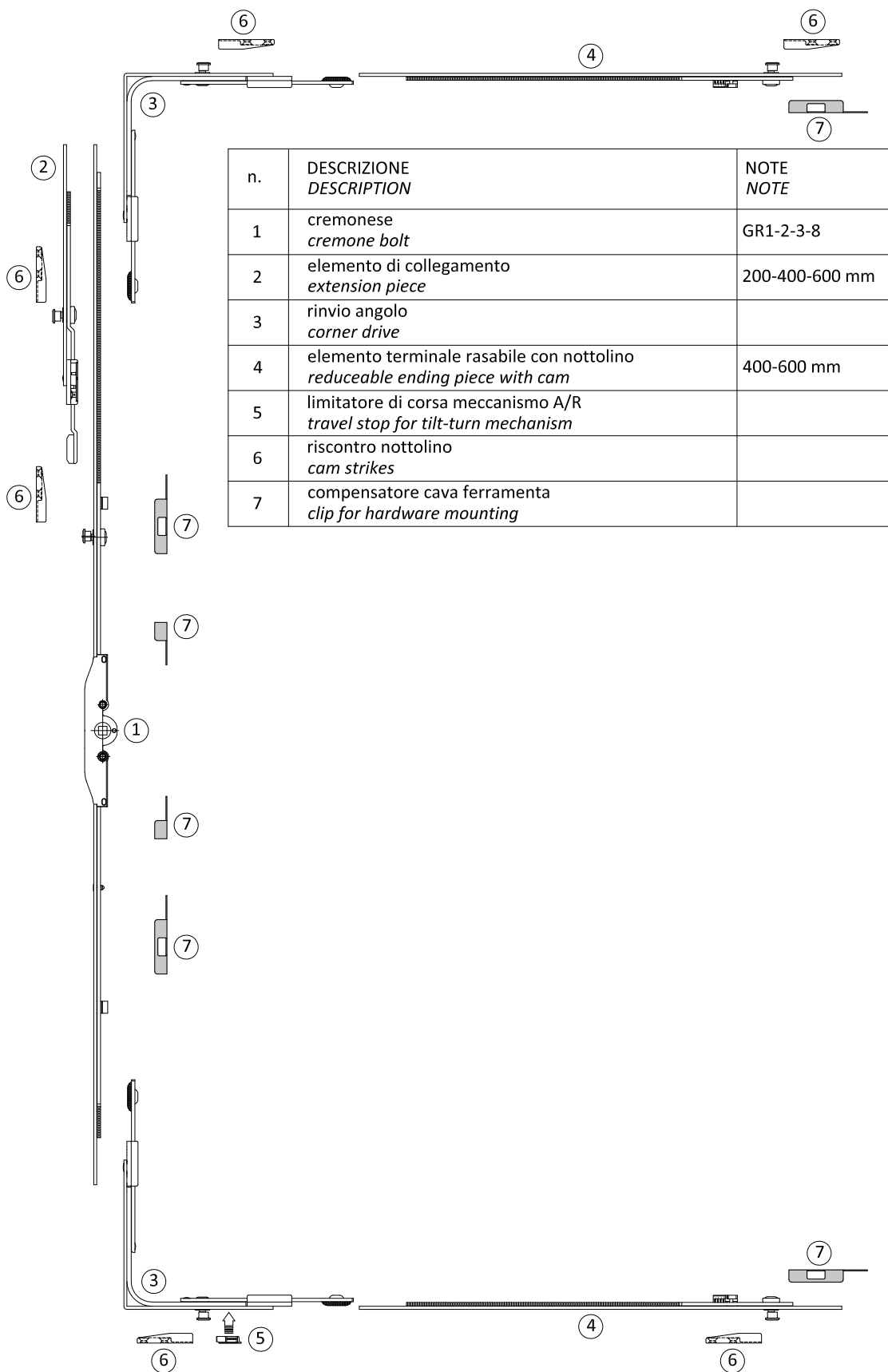
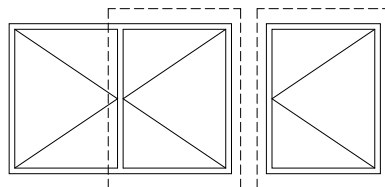

n.	DESCRIZIONE DESCRIPTION	NOTE NOTE
1	cremonese <i>cremone bolt</i>	GR1-2-3-8
2	elemento di collegamento <i>extension piece</i>	200-400-600 mm
3	rinvio angolo <i>corner drive</i>	
4	elemento terminale rasabile con nottolino <i>reduceable ending piece with cam</i>	400-600 mm
5	limitatore di corsa meccanismo A/R <i>travel stop for tilt-turn mechanism</i>	
6	riscontro nottolino <i>cam strikes</i>	
7	compensatore cava ferramenta <i>clip for hardware mounting</i>	

Easy

peso massimo anta 180 kg
(AC1237)
maximum leaf weight 180 kg
(AC1237)

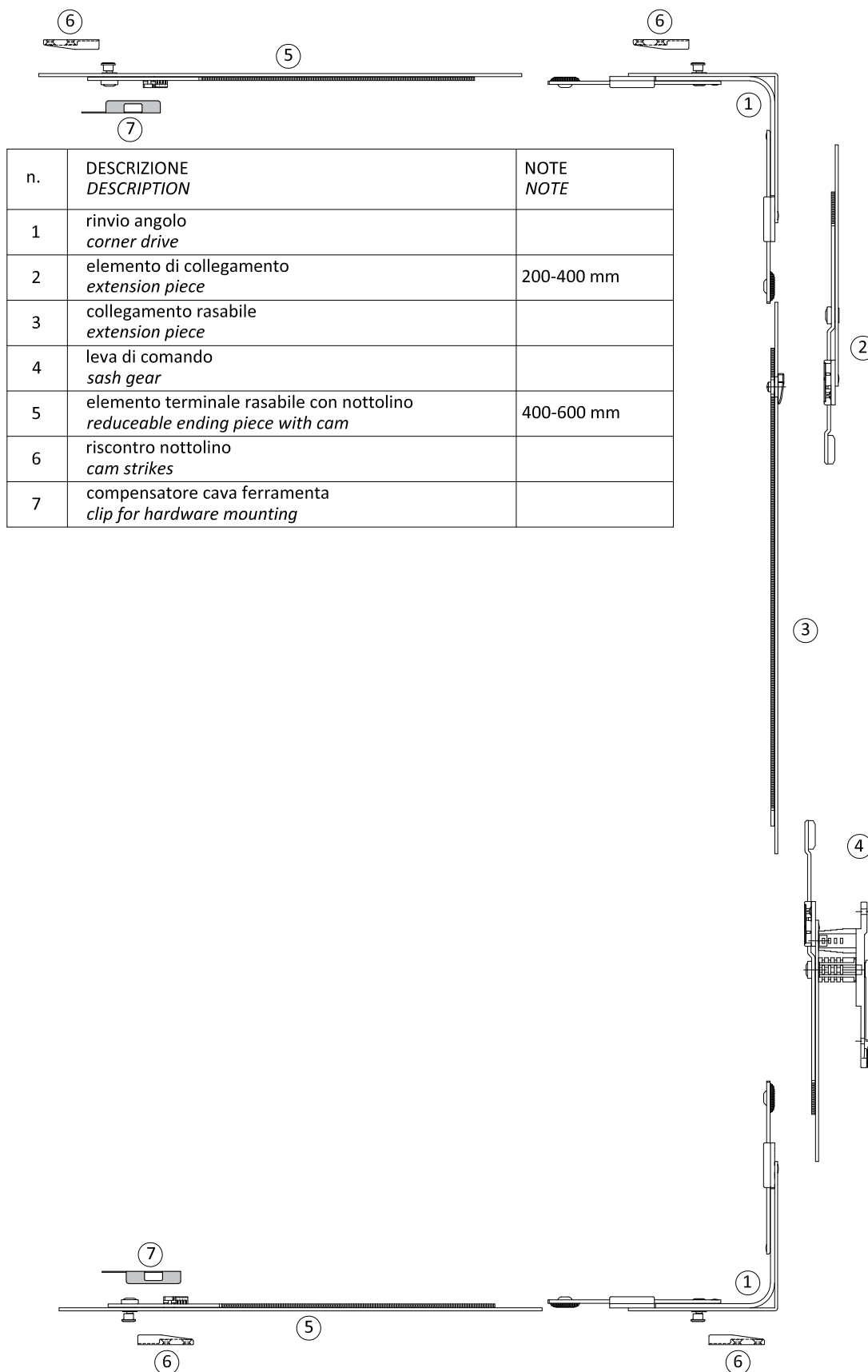
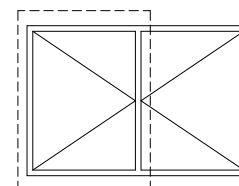

n.	DESCRIZIONE DESCRIPTION	NOTE NOTE
1	rinvio angolo corner drive	
2	elemento di collegamento extension piece	200-400 mm
3	collegamento rasabile extension piece	
4	leva di comando sash gear	
5	elemento terminale rasabile con nottolino reduceable ending piece with cam	400-600 mm
6	riscontro nottolino cam strikes	
7	compensatore cava ferramenta clip for hardware mounting	

Easy

peso massimo anta 180 kg
(AC1237)
maximum leaf weight 180 kg
(AC1237)

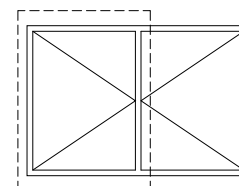

n.	DESCRIZIONE DESCRIPTION	NOTE NOTE
1	rinvio angolo inferiore lower corner drive	
2	catenaccio passante con maniglia bolt with control lever	Gr 2-3-4-5-6-7-8
3	elemento di collegamento con riscontro nottolino extension piece with cam	200-400 mm
4	rinvio angolo superiore upper corner drive with strike plate	
5	elemento terminale con nottolino ending piece with cam	400-600 mm
6	riscontro nottolino cam strikes	
7	compensatore cava ferramenta clip for hardware mounting	

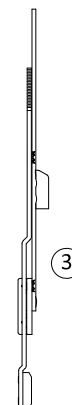

2

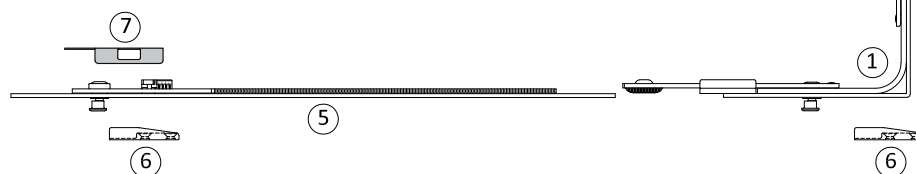

Easy RC2	H cava ferramenta H hardware slot [mm]	X [mm]	Y [mm]
	661 → 1000	183	173
	1001 → 1800	275	265
	1801 → 2400	855	845

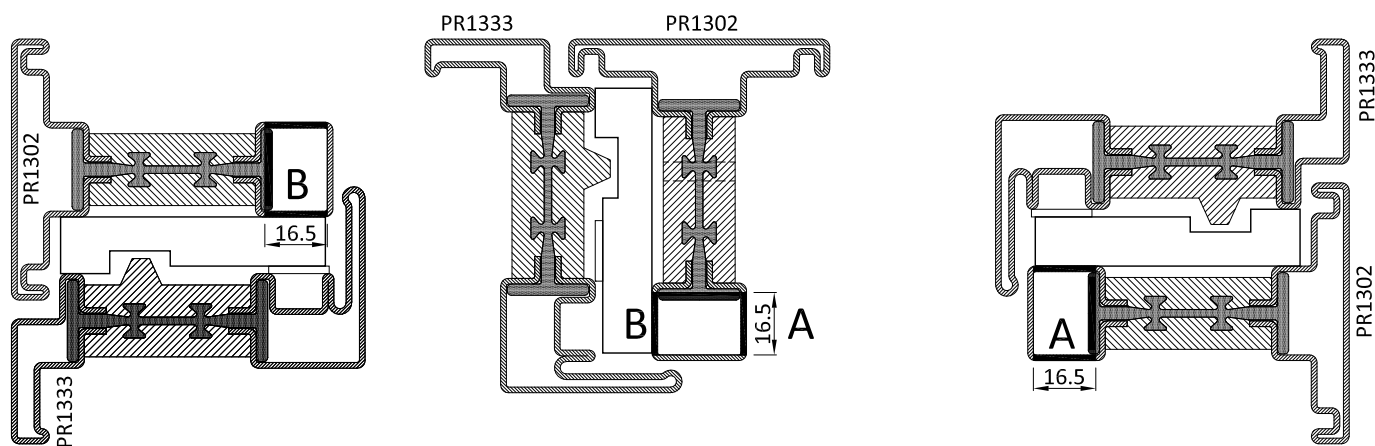
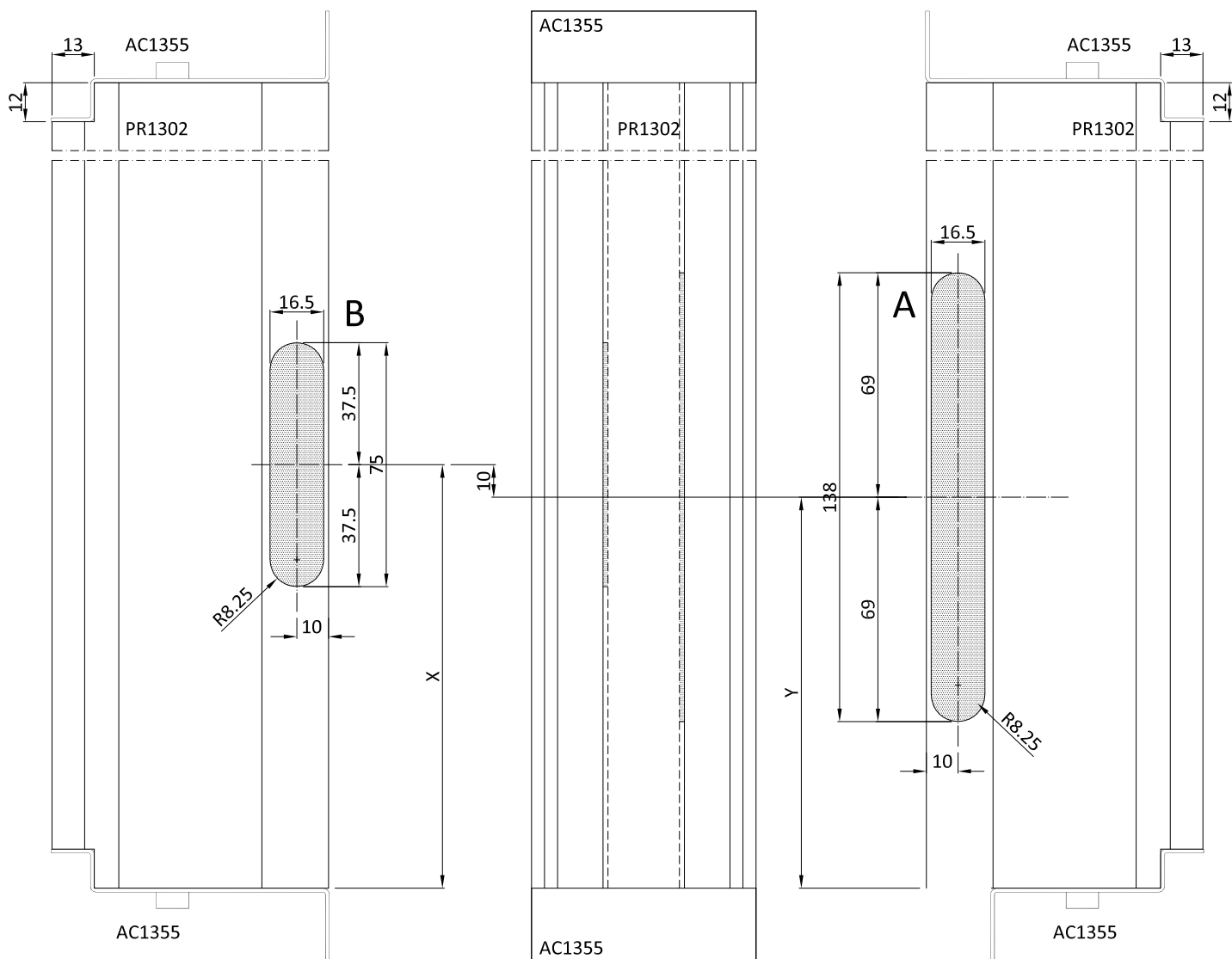
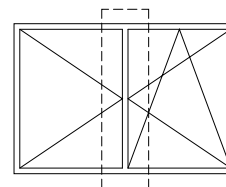

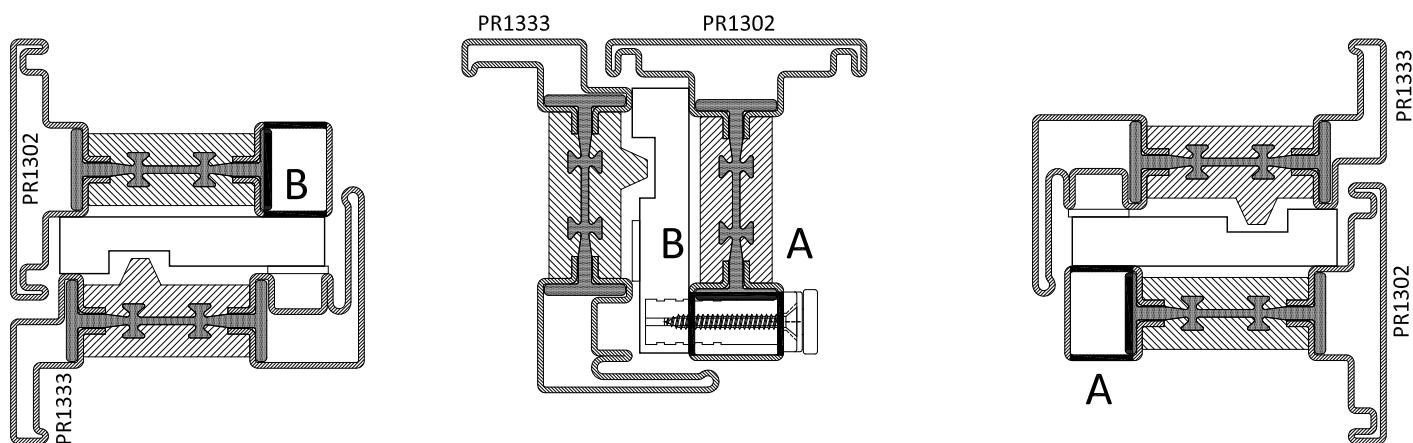
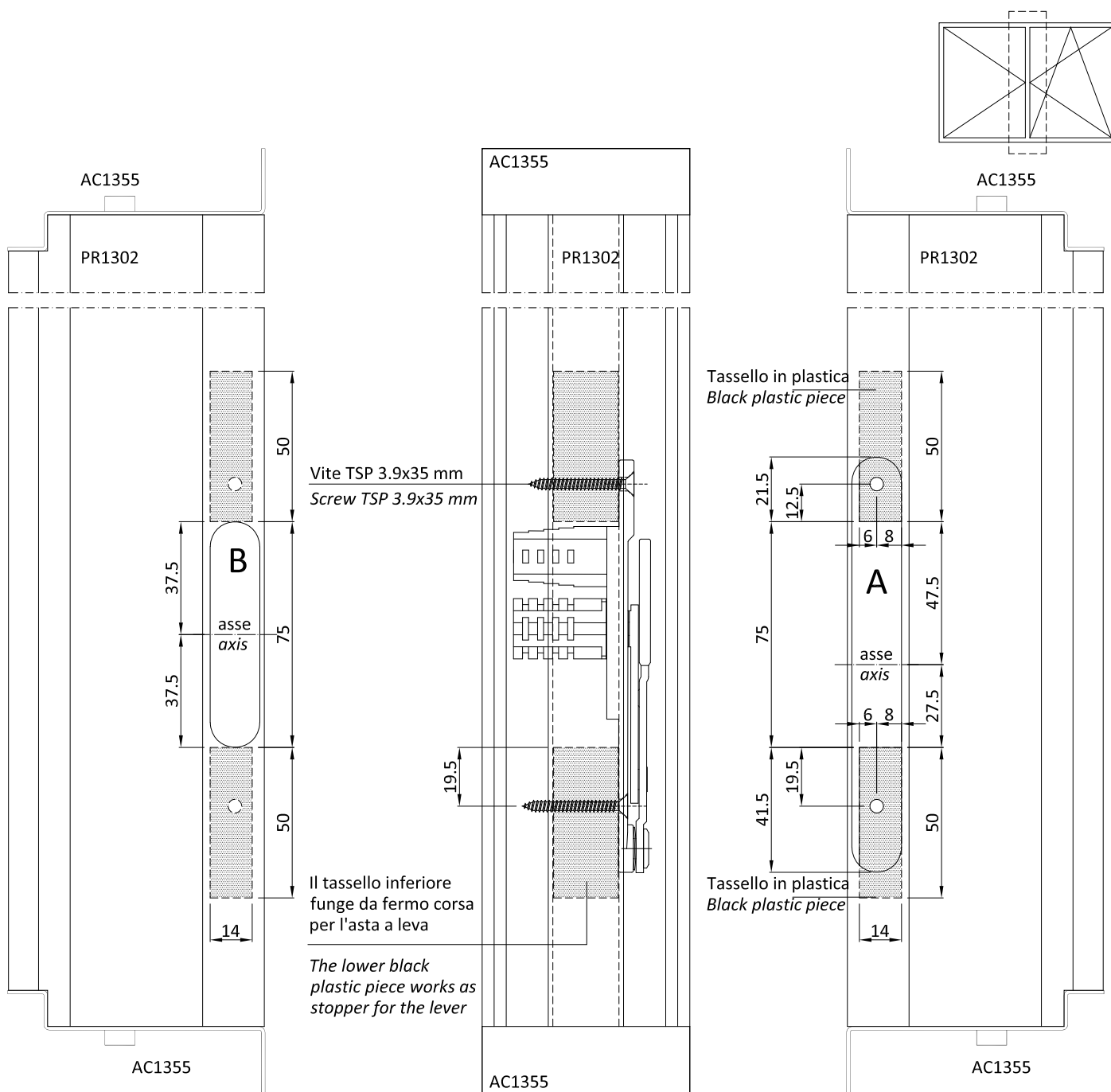

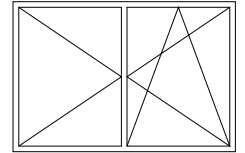

Lavorazione da eseguire sui componenti rasabili della ferramenta
Working on the cuttable pieces of the hardware

- 1 - Eseguire taglio della ferramenta sfalsato
- 2 - Eseguire foro e svasatura
- 1 - Cutting of the hardware
- 2 - Hole drilling and countersink

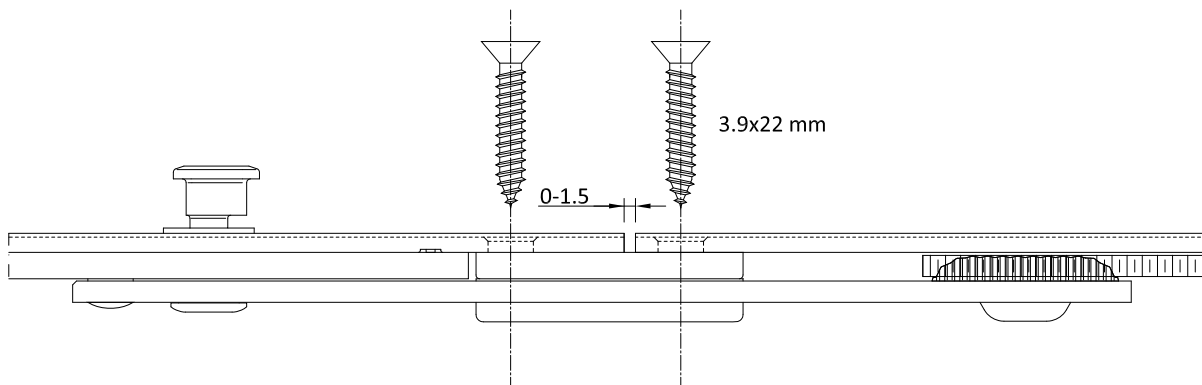
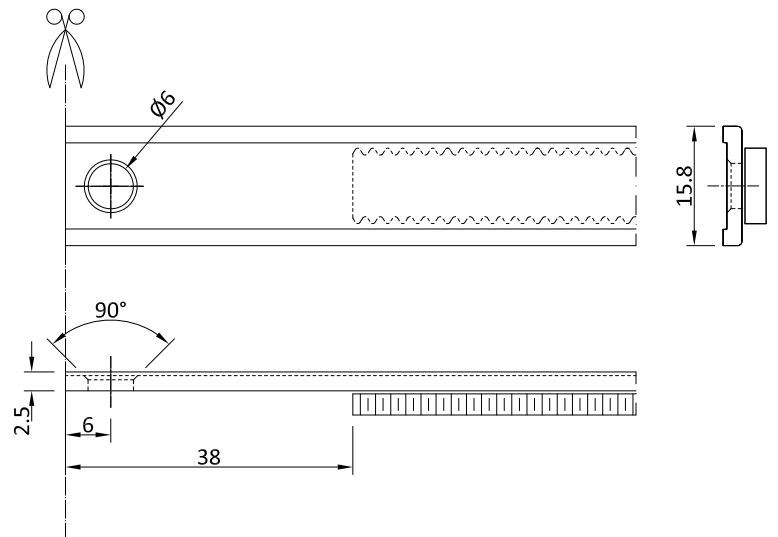

Lavorazione eseguibile con trancia ATG 311 o ATG 312
Tooling possible with punching machine ATG 311 or ATG 312

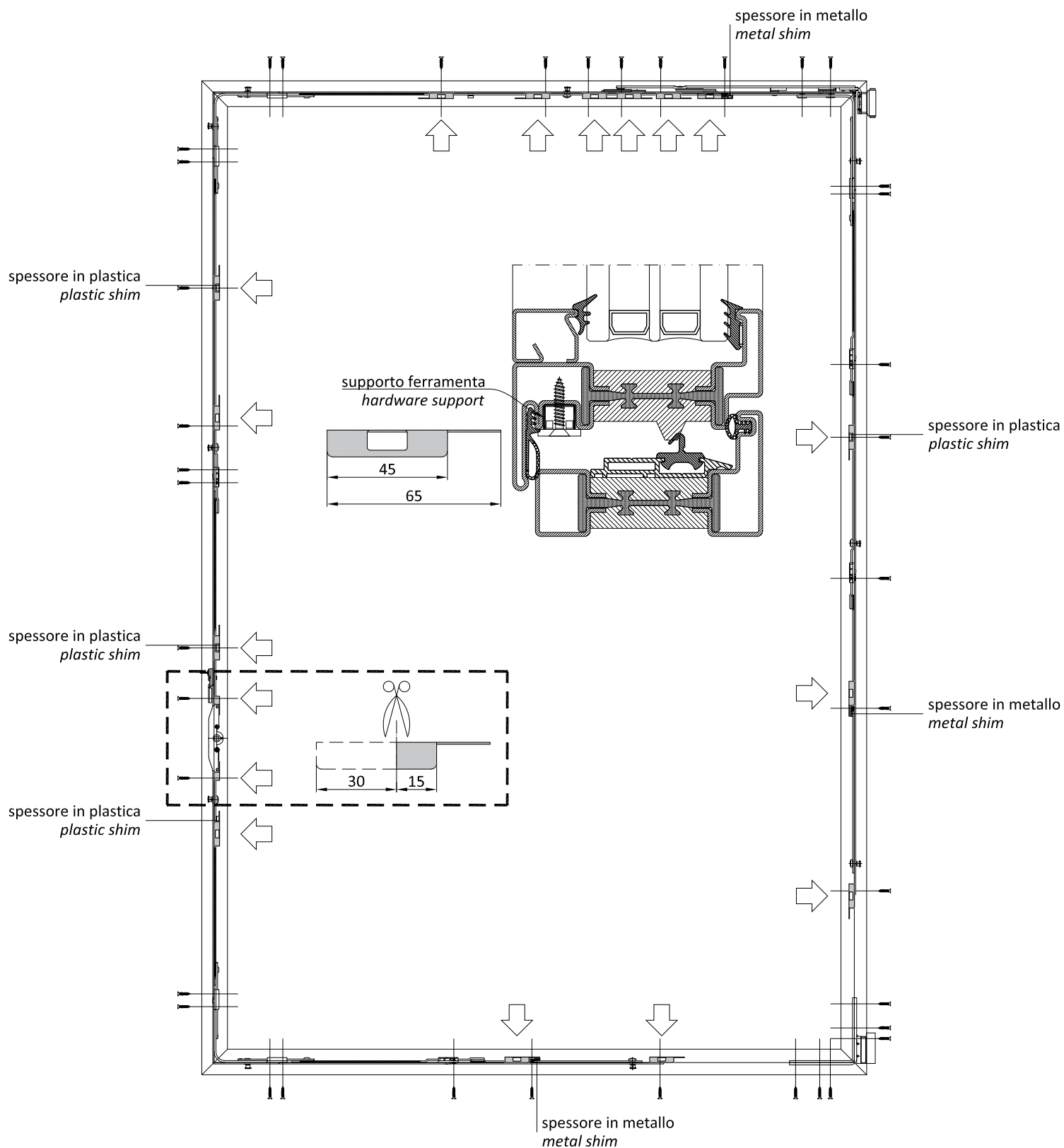
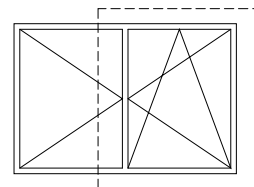

viti | screws TPS 3.9x22 mm



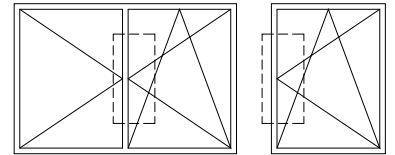

DSS

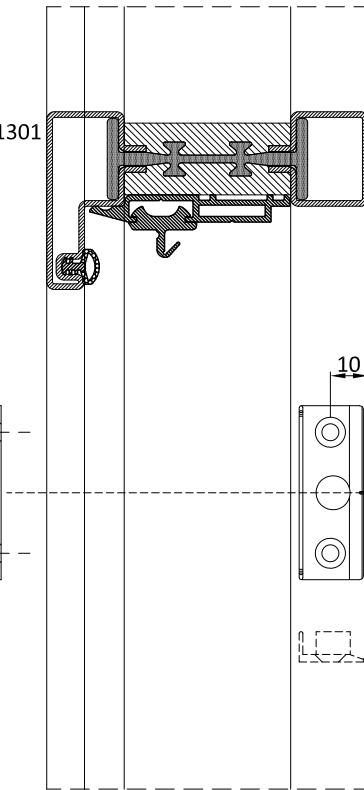
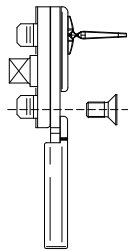
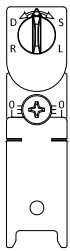

3.9x22 mm

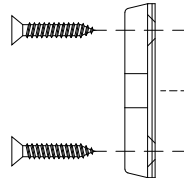

10

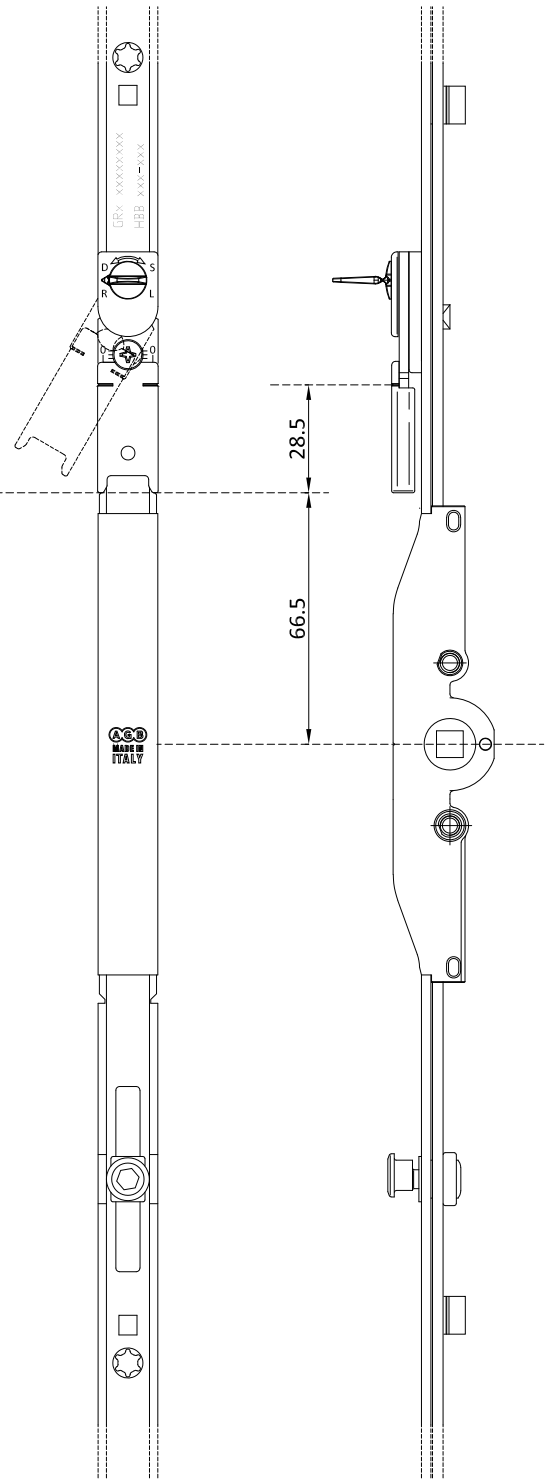

28.5
66.5

Regolazione
Adjustment

+3 mm

0 mm

-3 mm

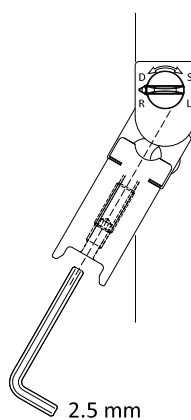
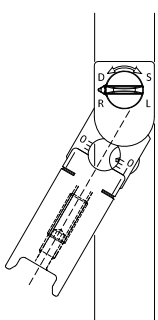

2.5 mm

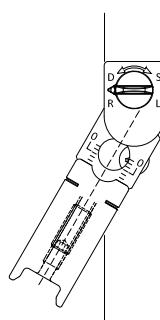

Easy

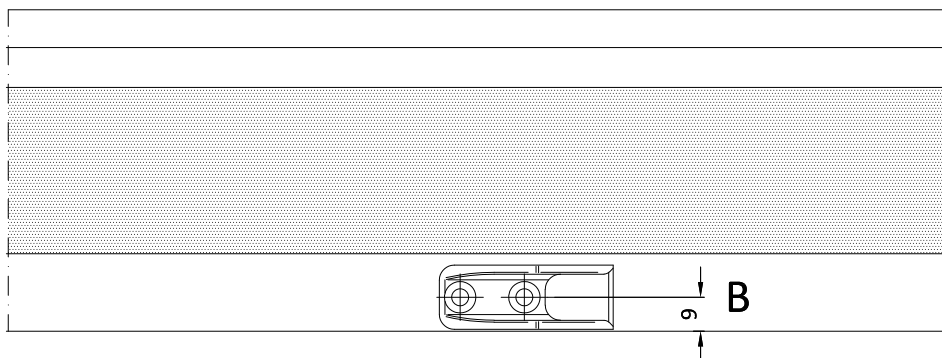
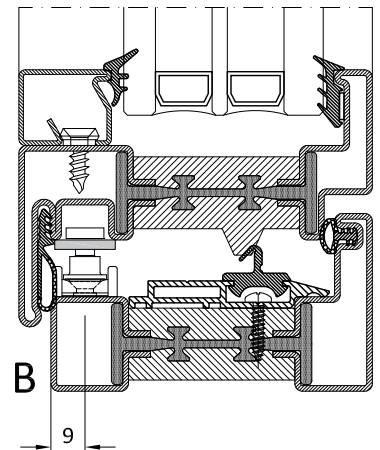
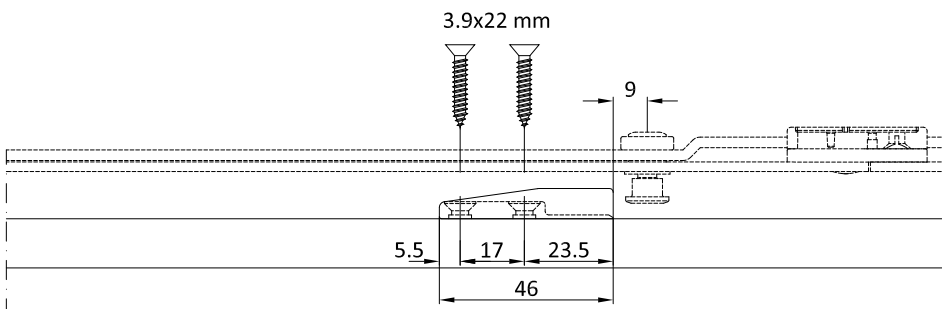
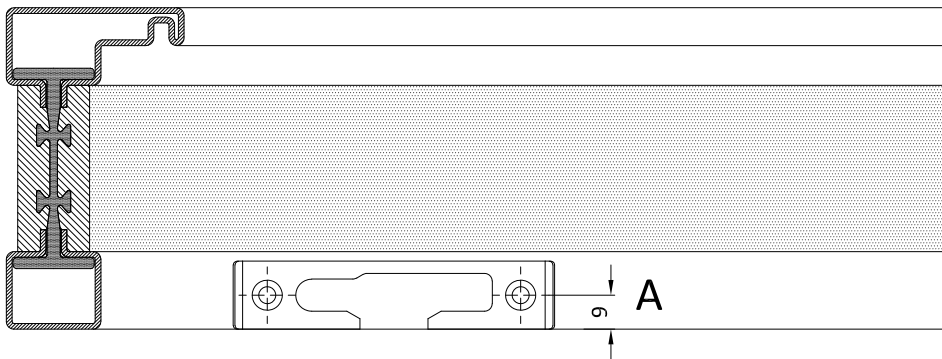
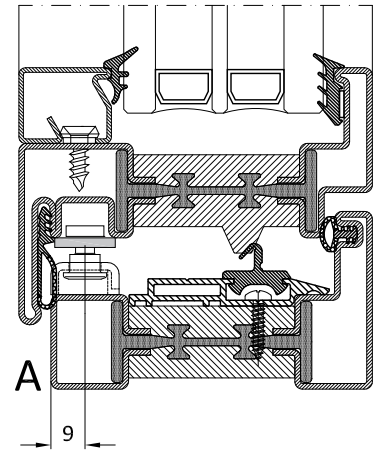
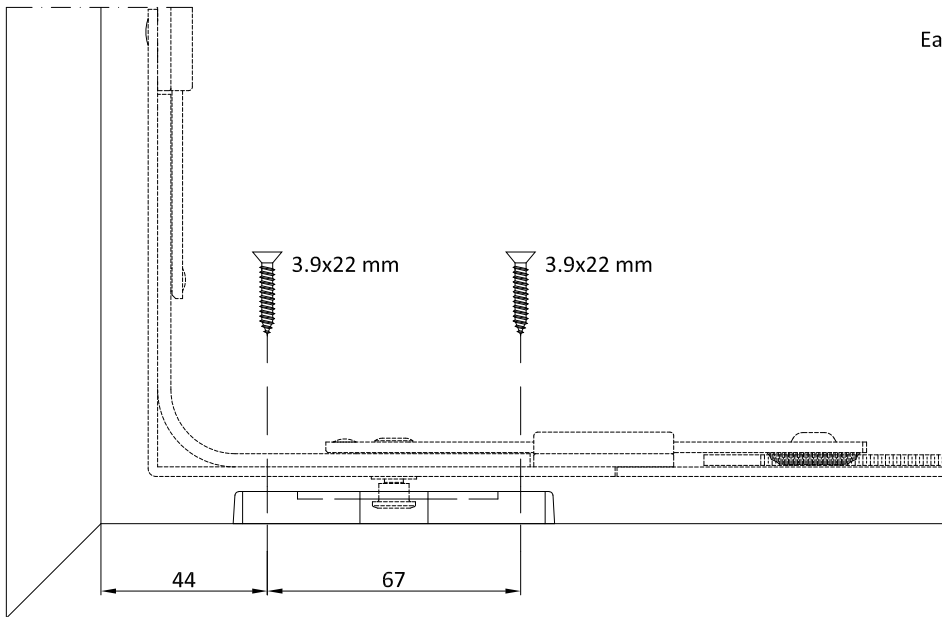
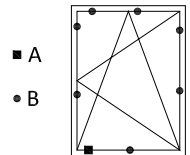

Easy

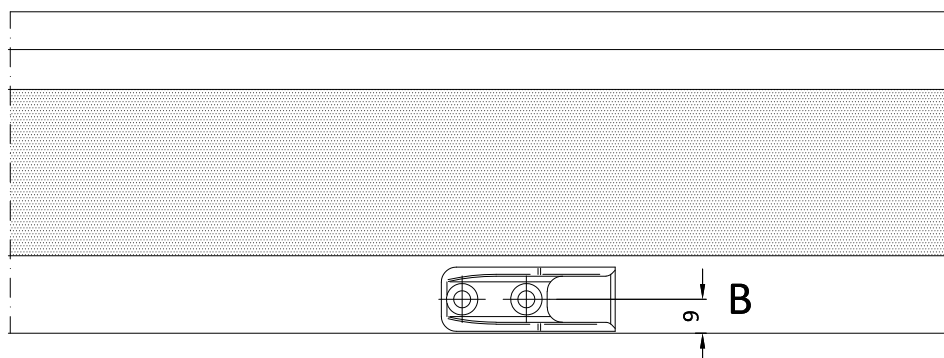
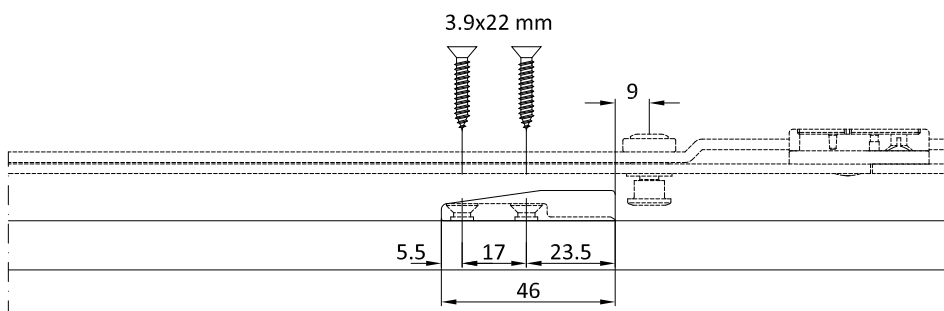
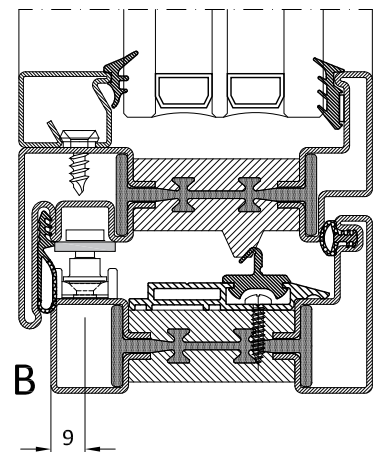
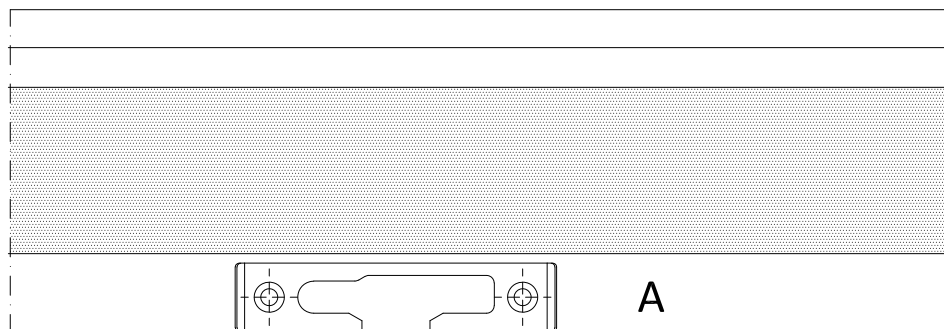
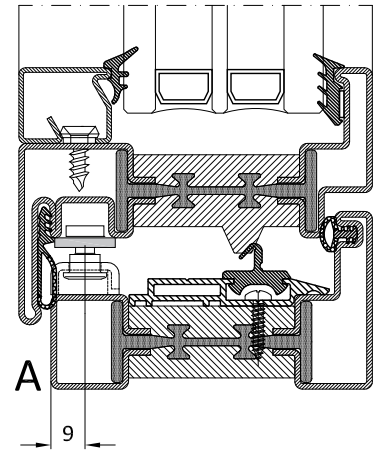
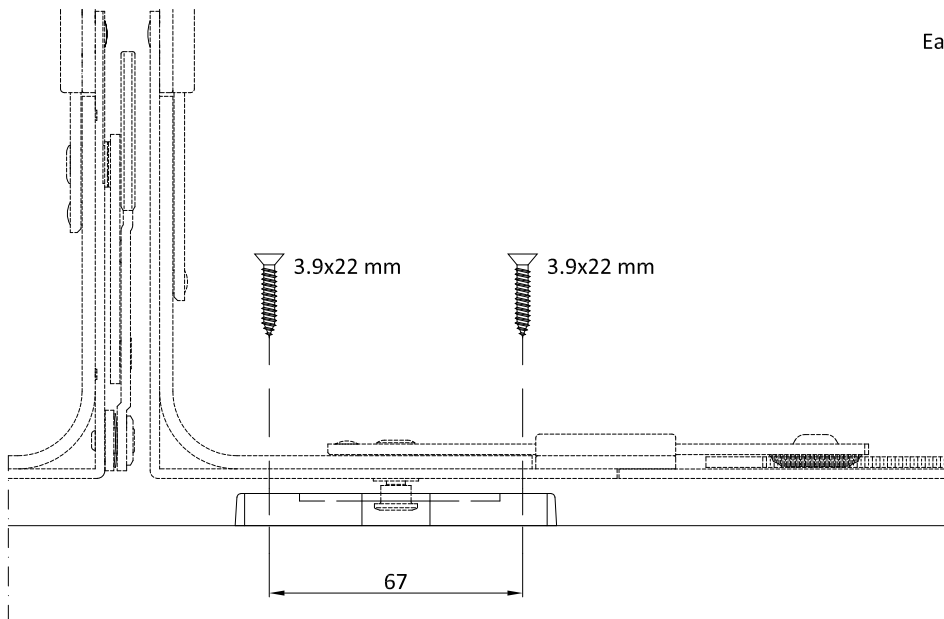
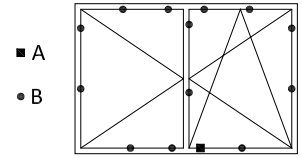

RC2

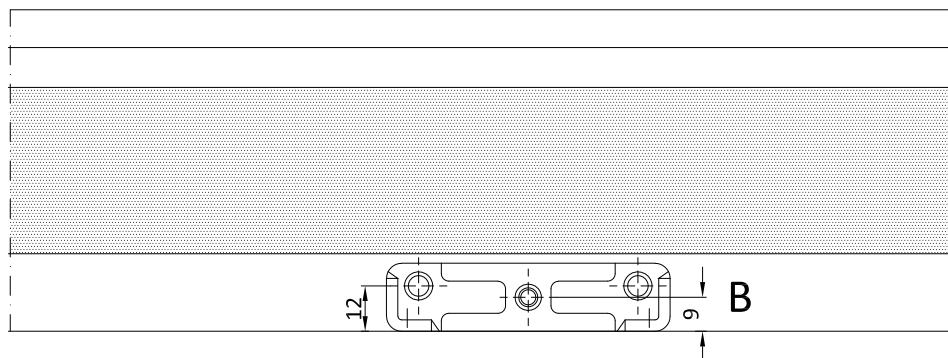
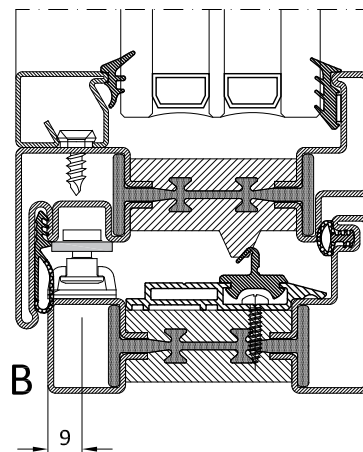
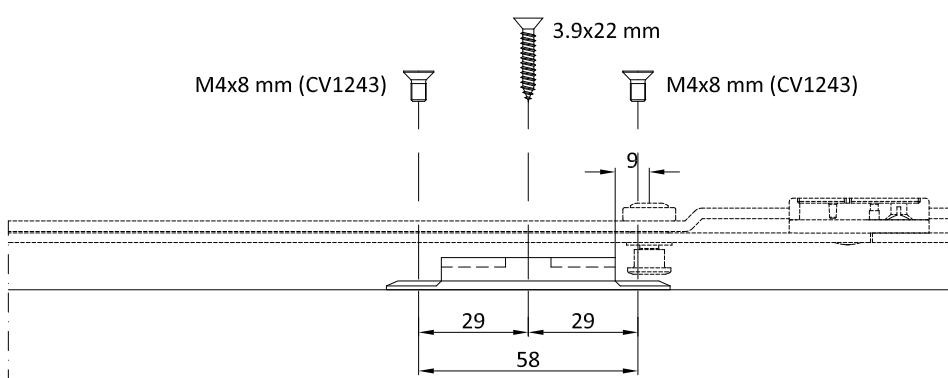
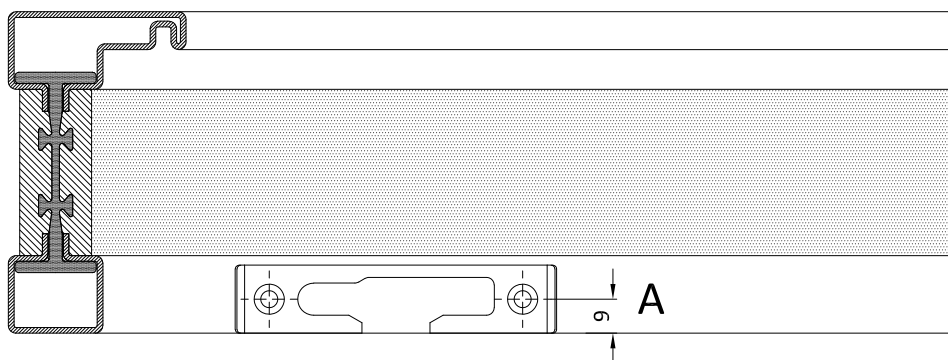
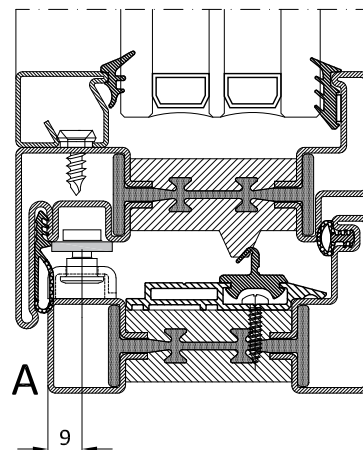
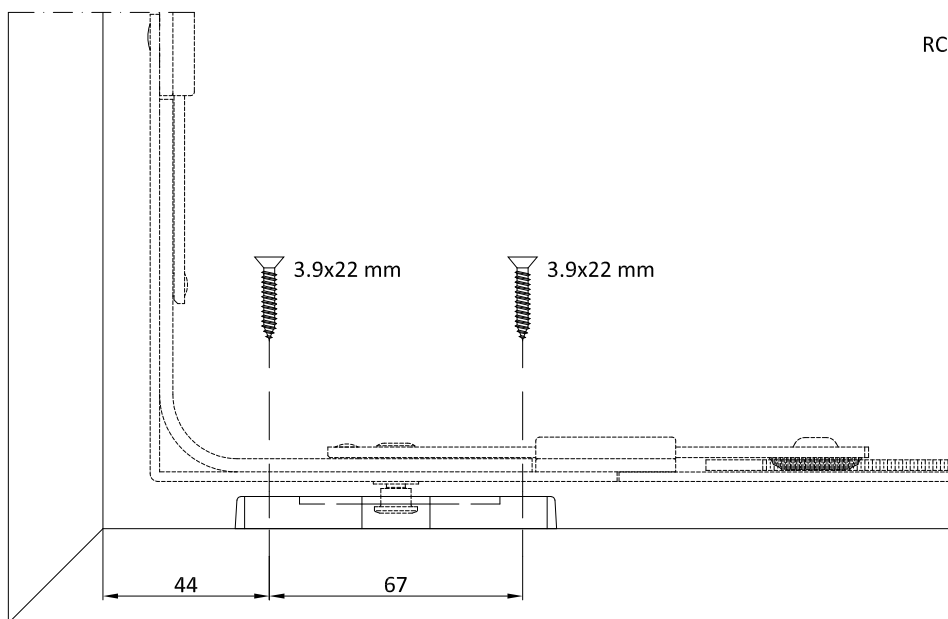
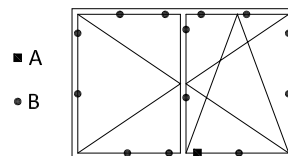

Fori eseguibili con
maschera ATG303
Holes to be done with
ATG303

RC2

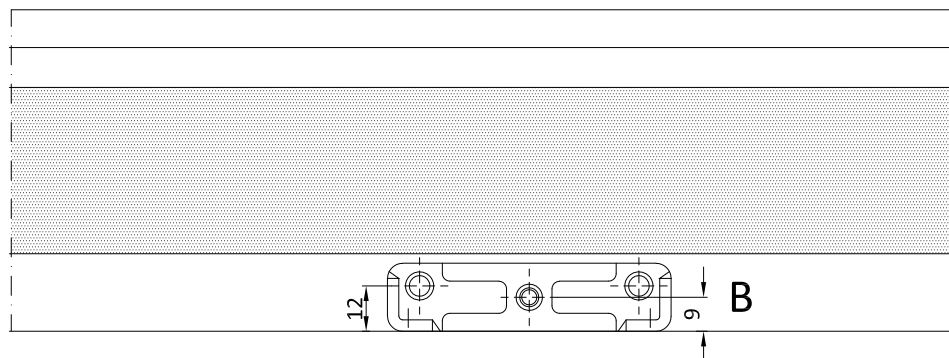
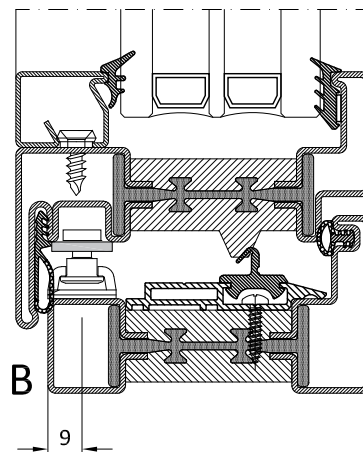
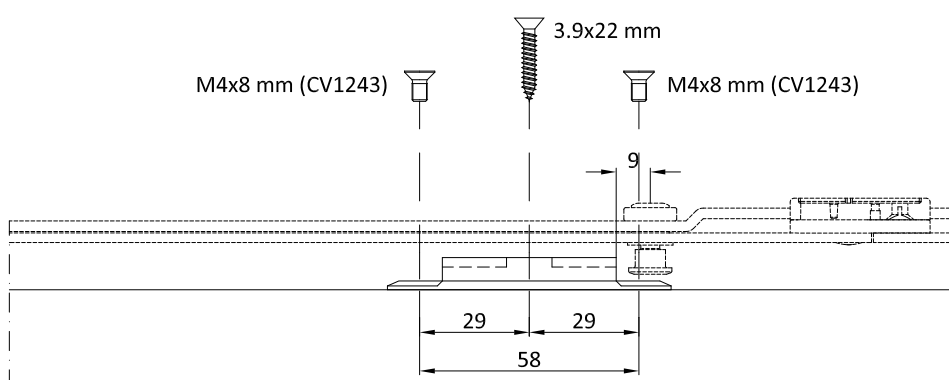
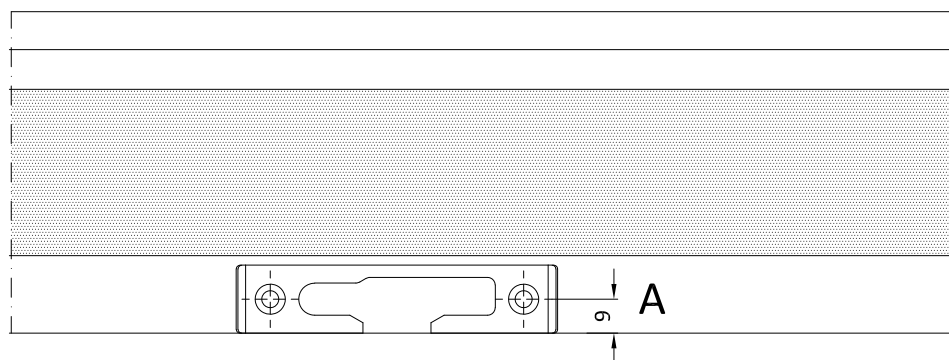
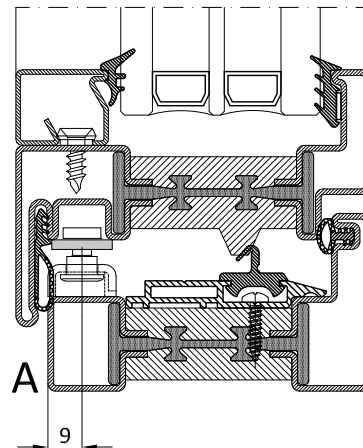
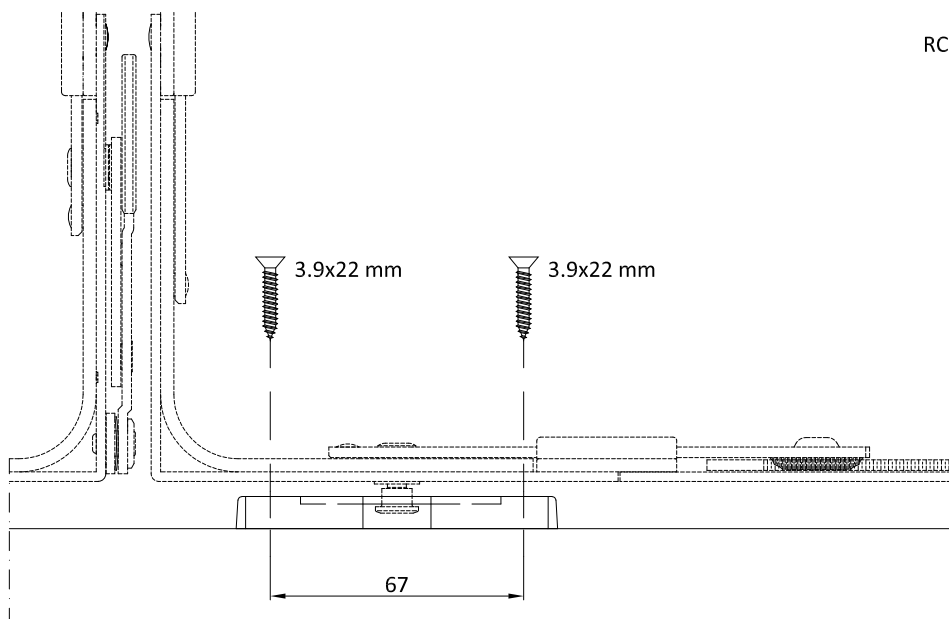
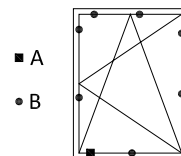

Fori eseguibili con
maschera ATG303
Holes to be done with
ATG303

AG6530

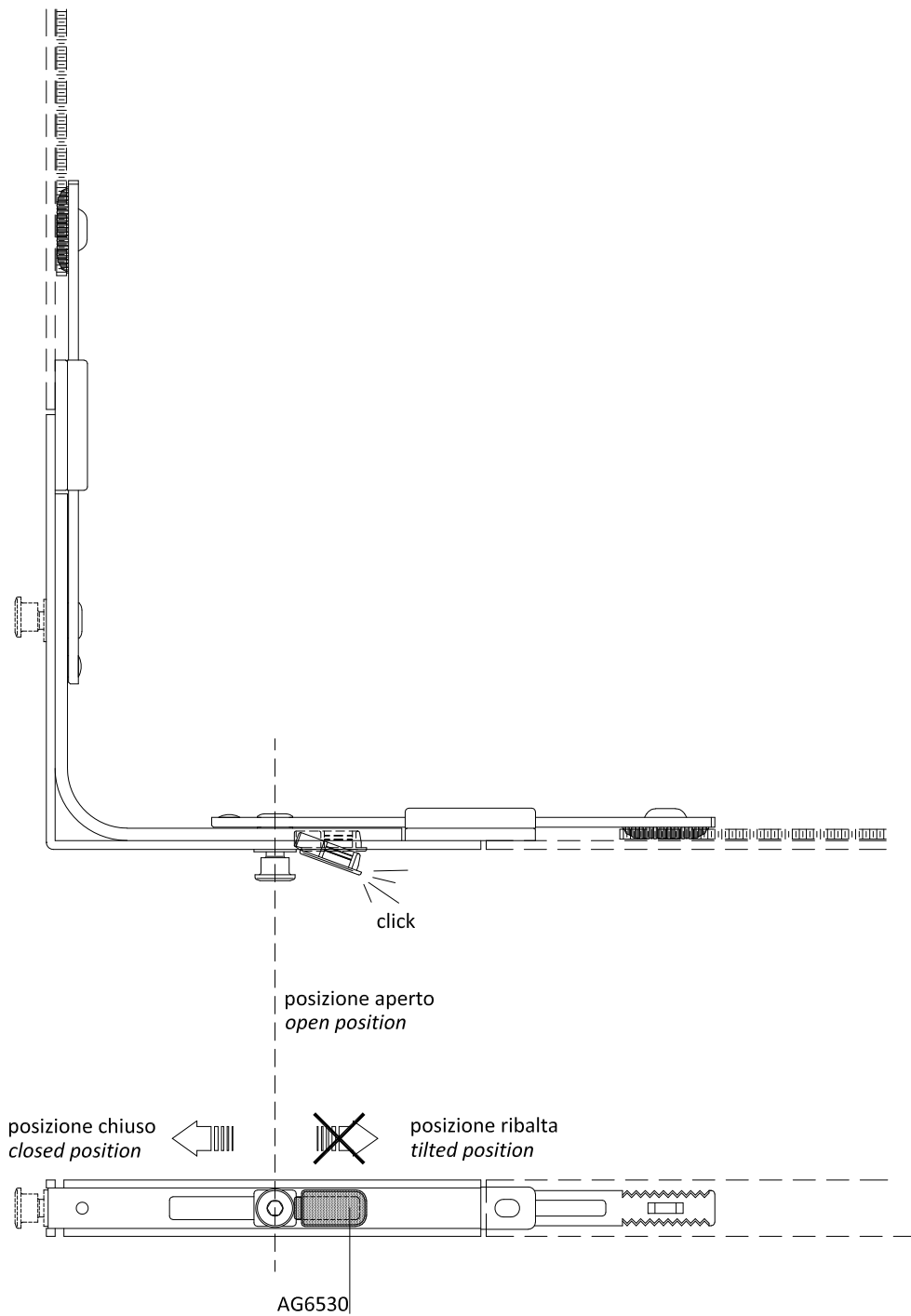
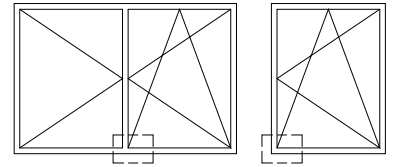
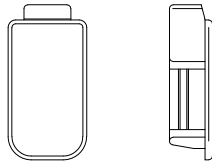

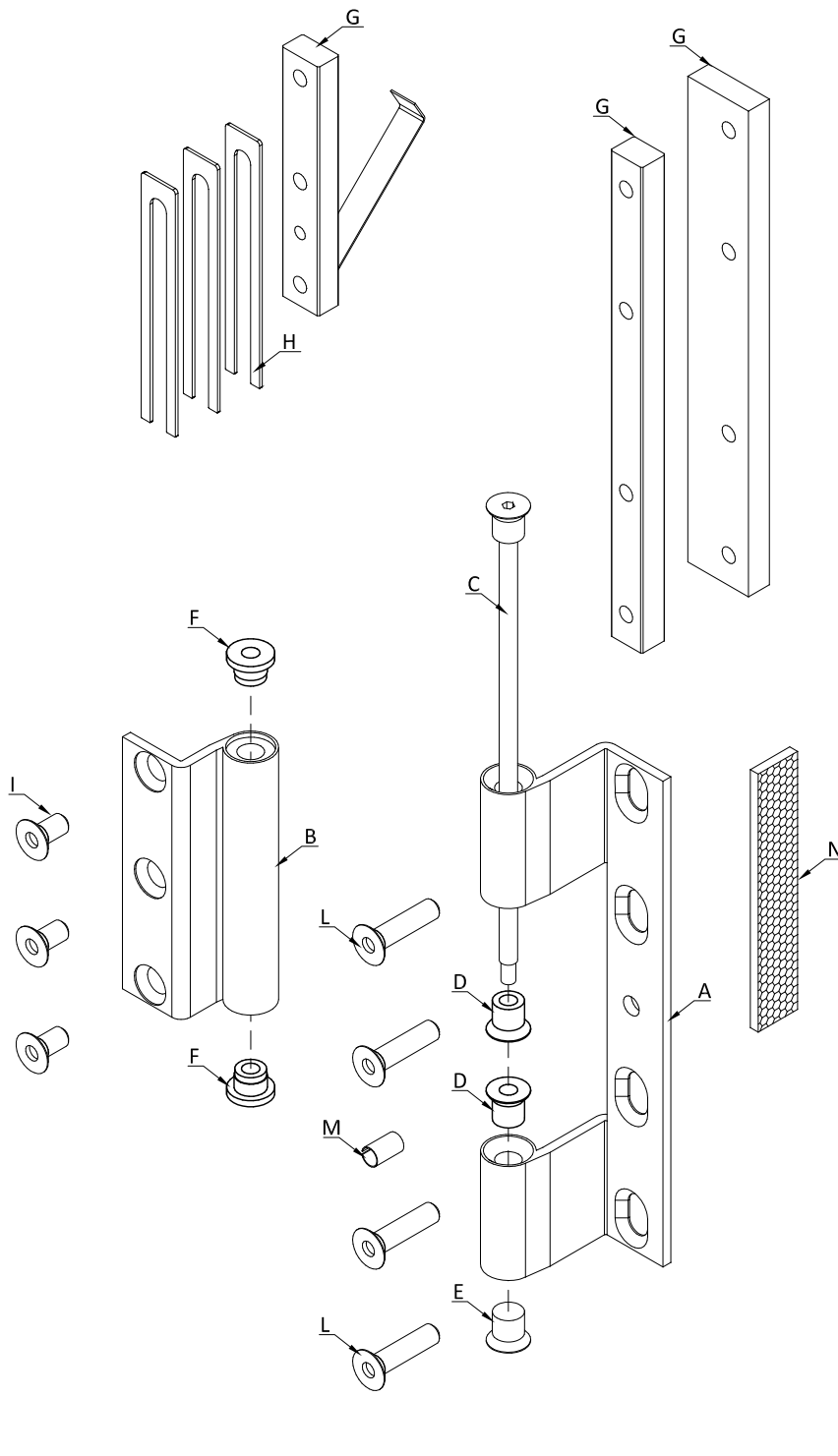
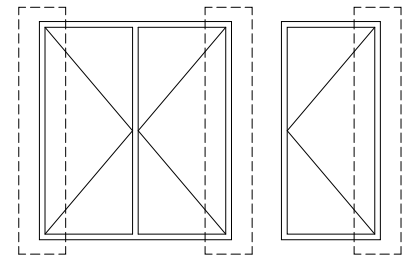

- A) Corpo cerniera A
- B) Corpo cerniera B
- C) Perno
- D) Guida perno
- E) Tappo a vite
- F) Bronzina
- G) Rinforzi interni
- H) Distanziale di regolazione
- I) Viti acciaio inox TSPEI M6 x 12 mm
- L) Viti acciaio inox TSPEI M6 x 25 mm
- M) Spina inox $\varnothing 6 \times 10$ mm da inserire dopo la regolazione dell'anta
- N) Guarnizione adesiva 15x3 mm

- A) Body hinge A
- B) Body hinge B
- C) Pin
- D) Pin groove/guide
- E) Screw cap
- F) Bronze bush
- G) Internal reinforcements
- H) Regulating spacer
- I) Stainless steel screws TSPEI M6 x 12 mm
- L) Stainless steel screws TSPEI M6 x 25 mm
- M) Stainless steel pin $\varnothing 6 \times 10$ mm to insert after regulating the leaf
- N) adhesive gasket 15x3 mm

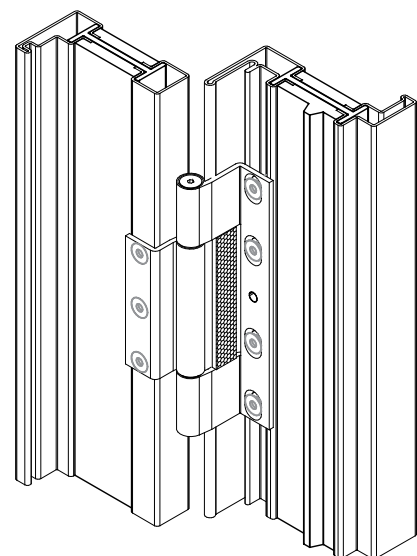

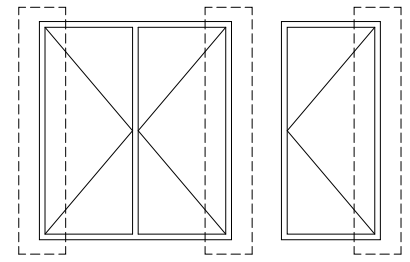
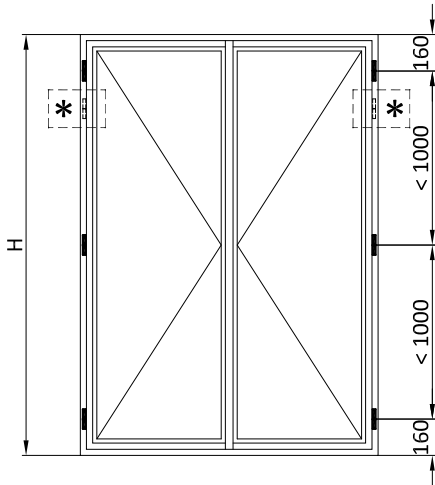

Peso max. per anta 180 kg
Max. weight for leaf: 180 kg

* Cerniera aggiuntiva per peso anta > di 180 kg - peso max 200 kg
Additional hinge for leaf weight > 180 kg - max weight 200 kg

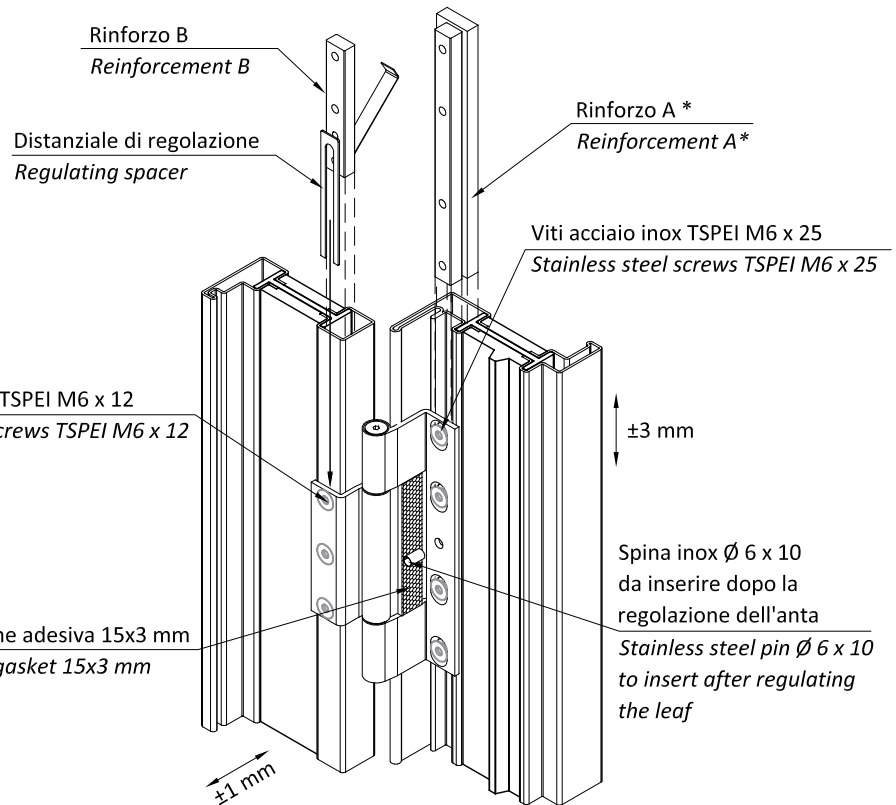
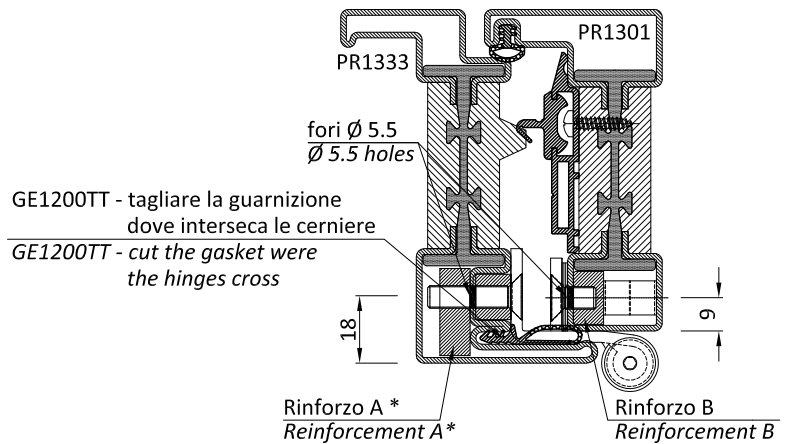
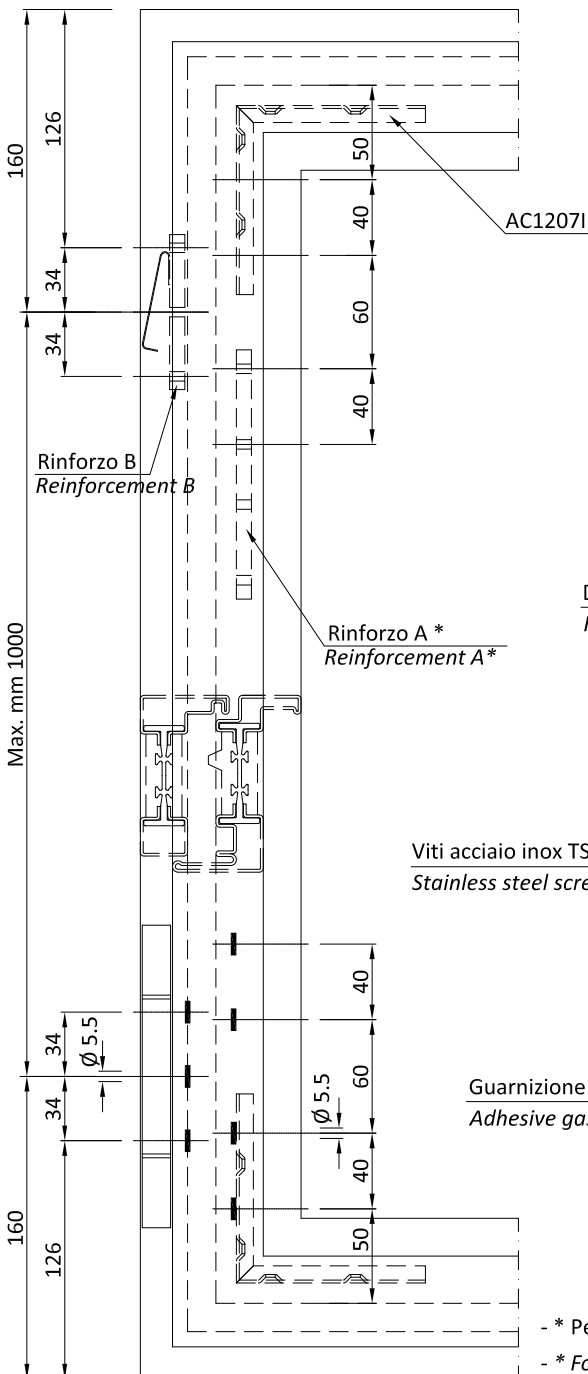

- * Per cerniere intermedie allineare i 4 fori di fissaggio della cerniera con i fori del rinforzo A
- * For intermediate hinges align the 4 anchoring holes of the hinge with the holes of reinforcement A

**LAVORAZIONE VALIDA ANCHE PER CERNIERE INTERMEDIE /
 AGGIUNTIVE**

Dopo aver tagliato montanti e traversi dell'anta e del telaio ed aver effettuato le lavorazioni delle squadrette, forare con punta $\varnothing 5,5$ il profilo "telaio" ed il profilo "anta" come indicato nel disegno.

Prima di assemblare il telaio e l'anta inserire i rinforzi "A" - "B" e bloccarli con le viti in dotazione.

Effettuare le medesime lavorazioni per la cerniera superiore e per le eventuali posizioni intermedie.

Forare la squadretta AC1207I di assiemaggio dell'anta e filettare i fori M5.

Dopo aver assemblato definitivamente l'infixo, vetri compresi, registrare le cerniere e bloccare l'elemento femmina della cerniera all'anta con la spina $\varnothing 6$ in dotazione

**TOOLING VALID ALSO FOR INTERMEDIATE/ADDITIONAL
 HINGES**

After cutting mullions and transoms for the wing and frame and carrying out the tooling with the corner brackets, drill the holes in the frame and wing profiles as indicated in the drawings. Use a $\varnothing 5.5$ drill bit.

Before assembling the frame and the wing, insert the reinforcements "A" - "B" and secure them with the screws provided.

Carry out the same procedures for the upper hinge and for any other mid positions.

Drill a hole in the AC1207I assembling bracket for the wing and thread the M5 holes.

After assembling the door/window, glass included, adjust the hinges and secure the female element of the hinge to the wing with the $\varnothing 6$ pin provided.

PER ANTE CON PESO SUPERIORE A 180 kg

Eeguire sulla cerniera due fori svasati $\varnothing 4,5$ dopo aver assemblato definitivamente l'infixo, vetri compresi, registrare le cerniere e bloccare con la spina $\varnothing 6$ in dotazione l'elemento femmina sull'anta e l'elemento maschio al telaio con due viti TPS 4,2x13

FOR WINGS HEAVIER THAN 180 kg

After assembling the door/window, glass included, drill 2 $\varnothing 4.5$ countersunk holes in the hinge; adjust the hinges and secure the female element of the hinge to the wing with the $\varnothing 6$ pin provided and the male element to the frame with 2 TPS 4.2x13 screws.

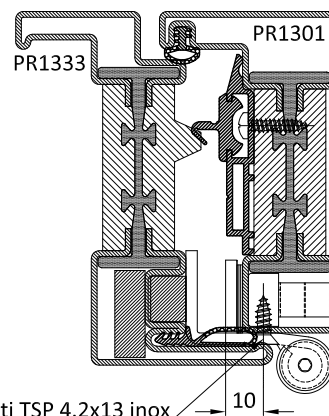
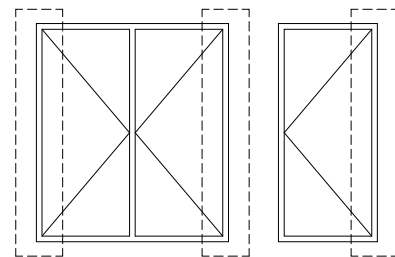

Viti TSP 4.2x13 inox
 Stainless steel
 screws TSP 4.2x13

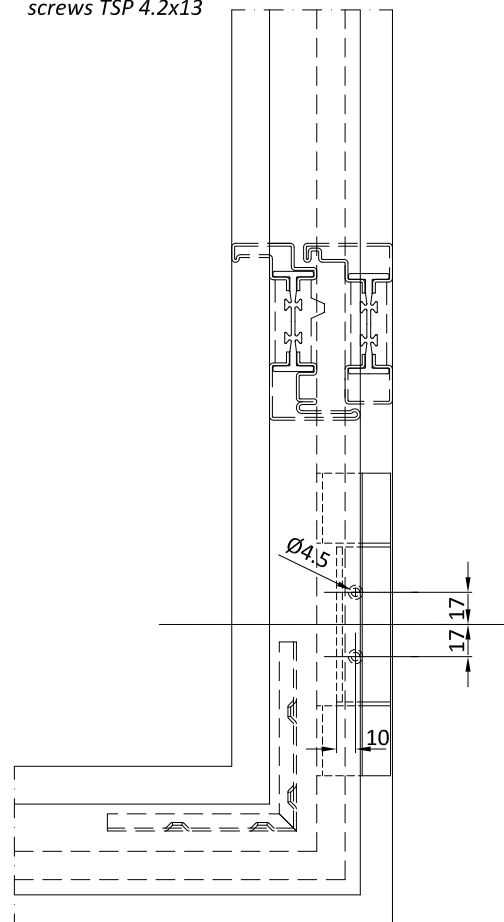

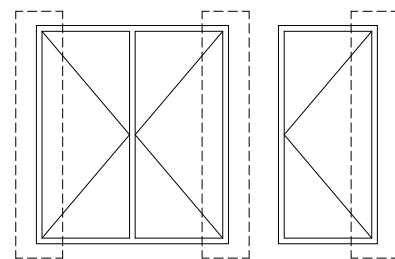
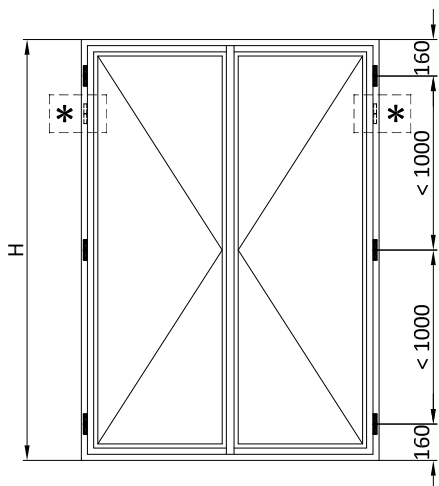

Peso max. per anta 80 kg
Max. weight for leaf: 80 kg

* Cerniera aggiuntiva per peso anta > di 80 kg - peso max 100 kg.
Additional hinge for leaf weight > 80 kg - max weight 100 kg

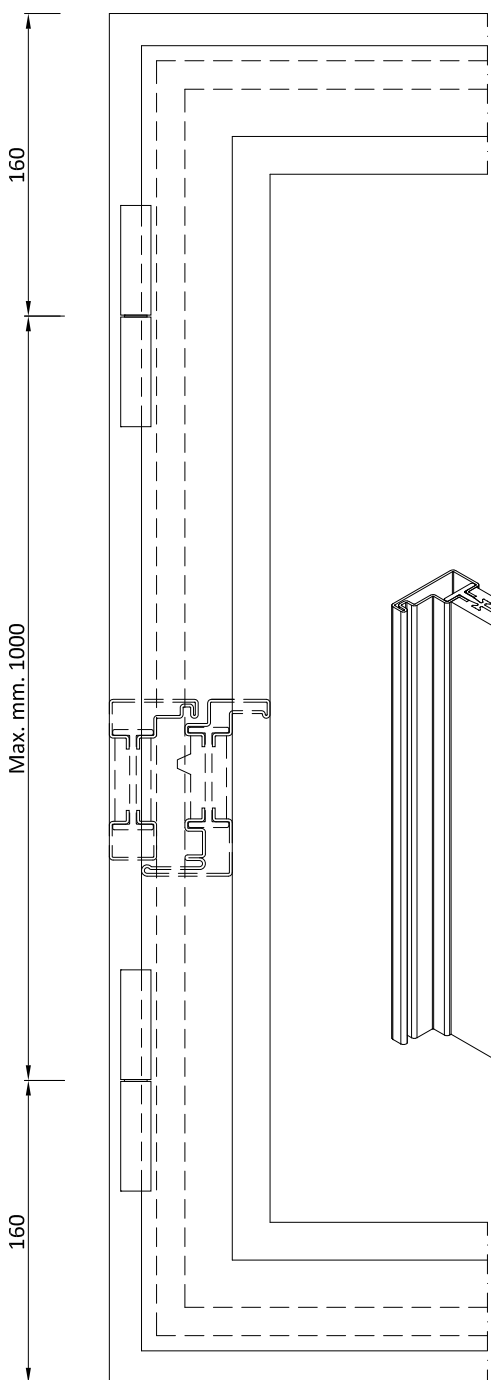

Posizionare le cerniere come da disegno saldandole sui alti.
Position the hinges as in the drawing, welding them on the sides.

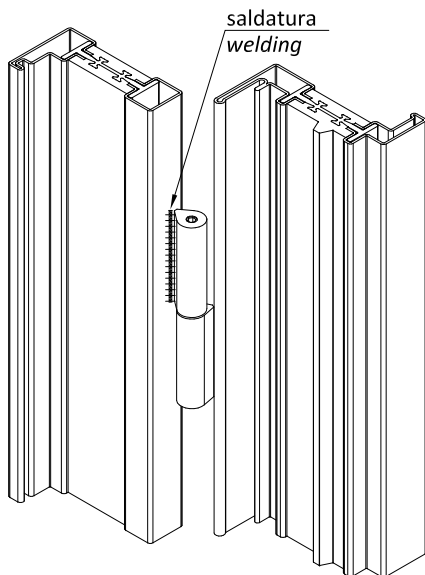
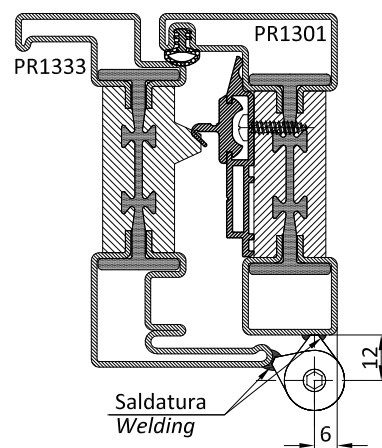

± 2 mm.

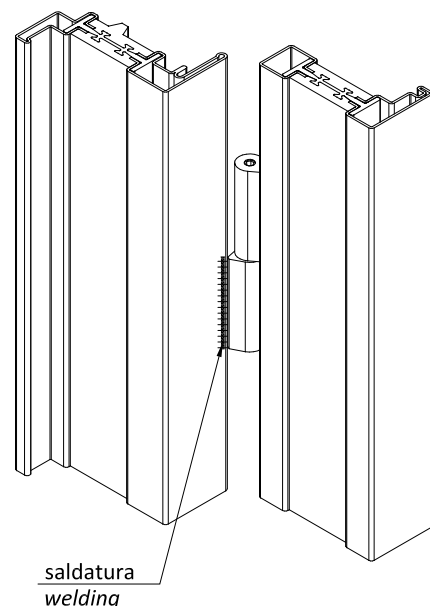

- La lavorazione può essere effettuata anche in posizioni intermedie dell'altezza della finestra.
- La lavorazione SX è speculare alla DX.

- Tooling can be carried out also in intermediate positions regarding the height of the window.
- Tooling on left is the same as that on the right.

α	x [mm]	min. cava ferramenta hardware slot min. [mm]
30°	192	445
45°	182.5	435
90°	130	385
100°	117.5	370

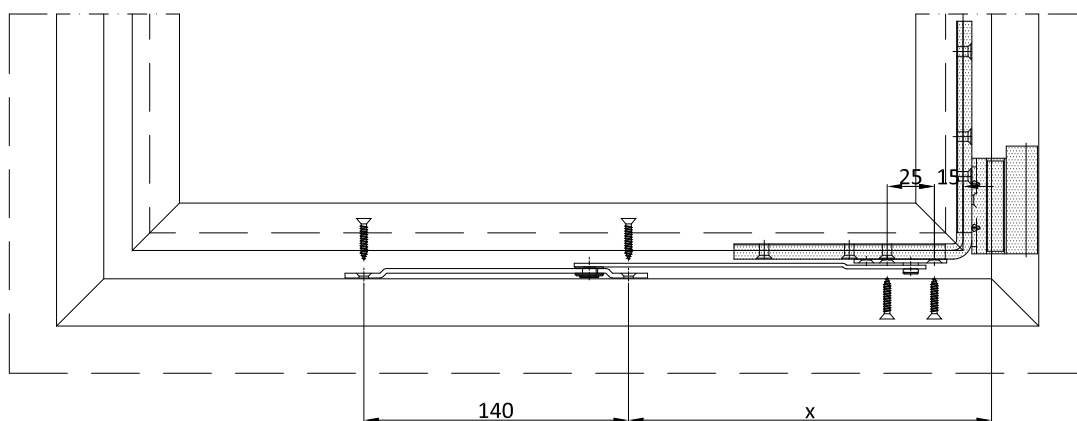
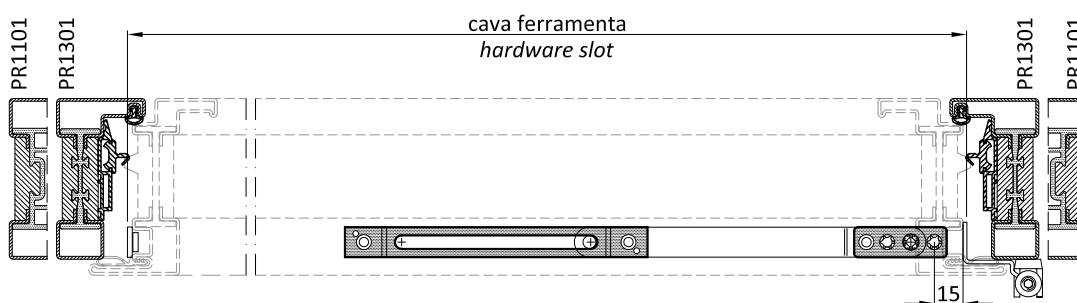
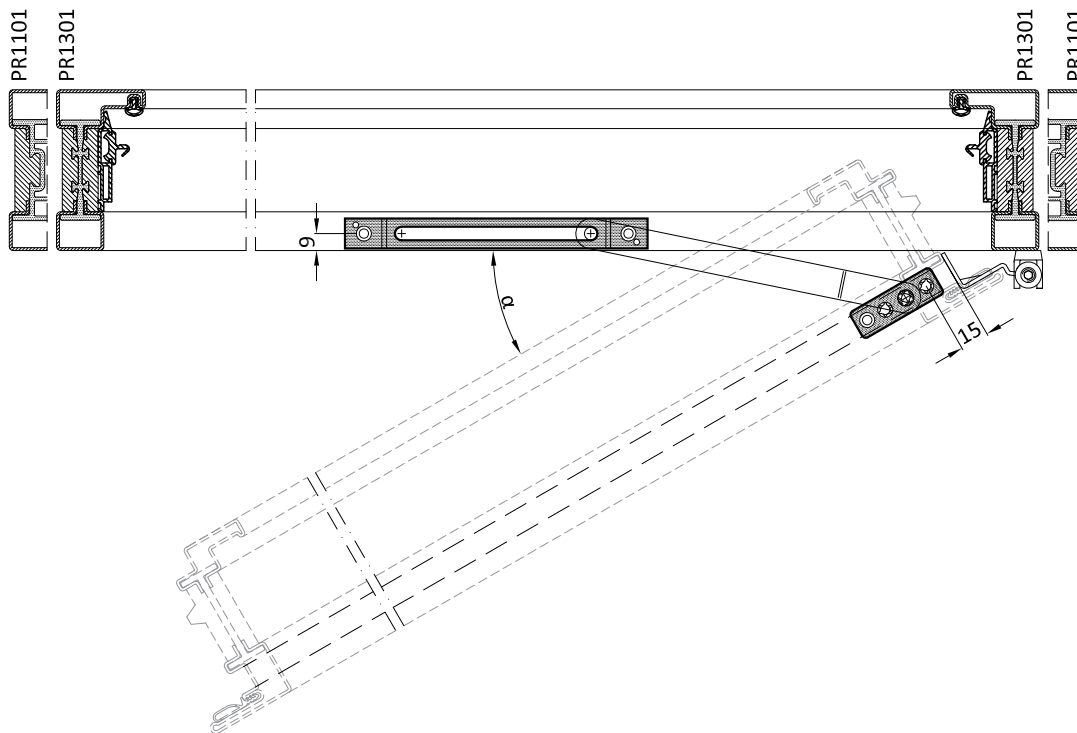
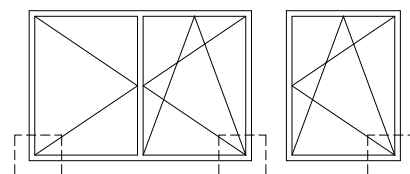

non installabile su kit AG1271-2-5-6
not possible to install on kit AG1271-2-5-6



α	x [mm]	min. cava ferramenta hardware slot min. [mm]
30°	196	450
45°	186	440
90°	130.5	380
100°	117.5	370

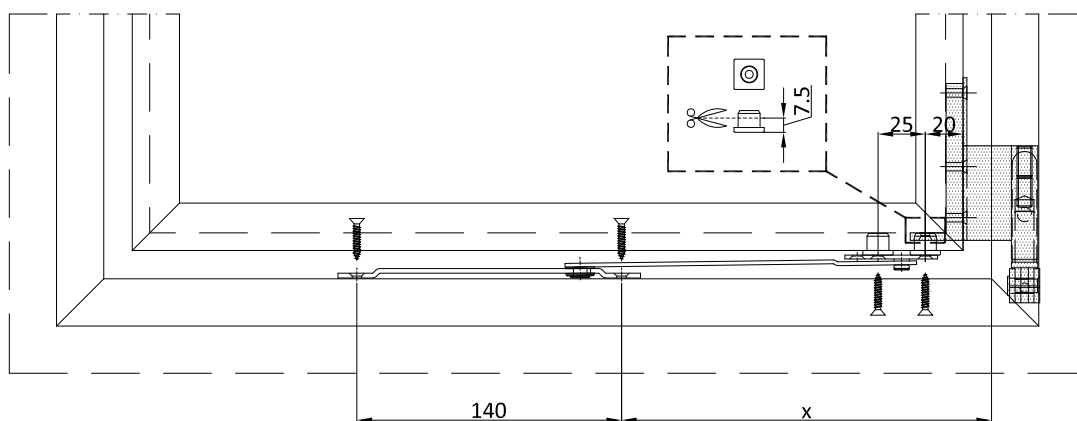
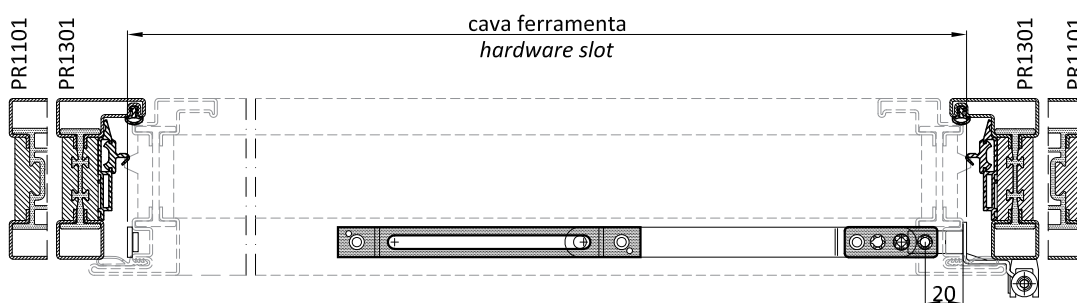
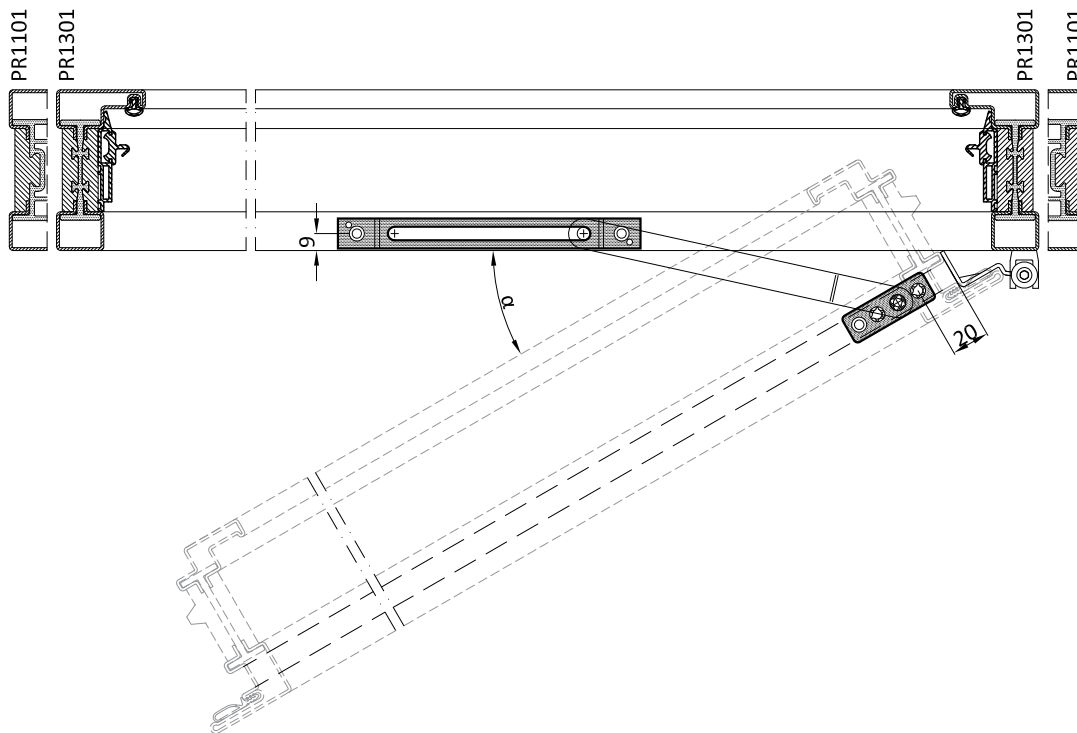
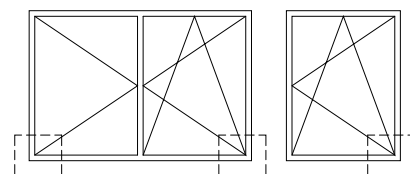

non installabile su kit AG1291-2-5-6
not possible to install on kit AG1291-2-5-6



α	x [mm]	y [mm]	min. cava ferramenta hardware slot min. [mm]
90°	31	16.3	450
100°	19	4.3	450

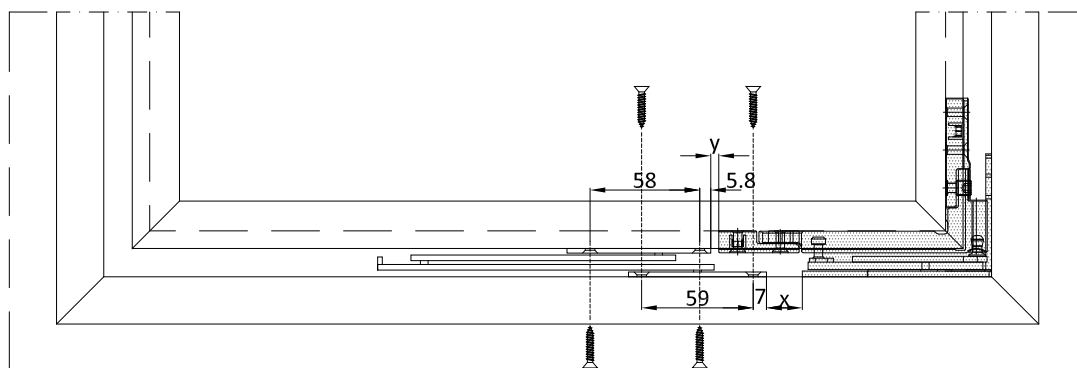
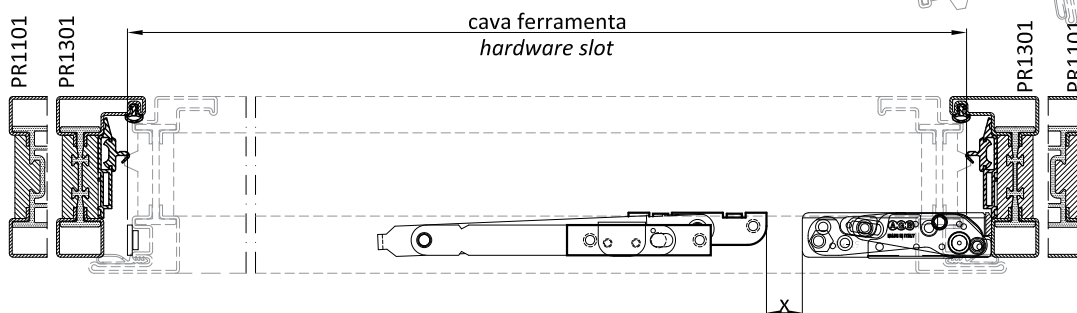
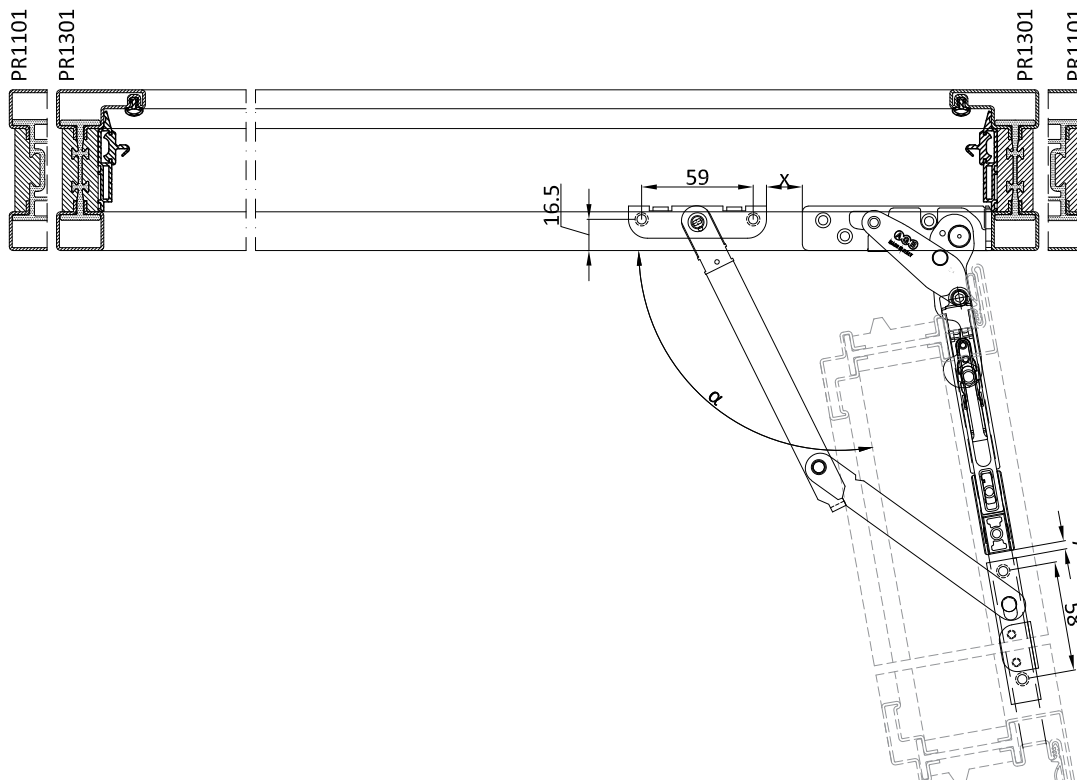
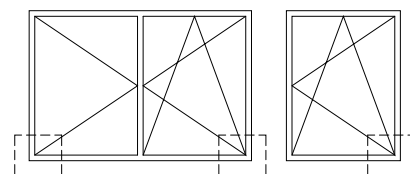

non installabile su kit AG1281-2-5-6
not possible to install on kit AG1281-2-5-6



		H altezza - Height			
AG1264		560 660	661 860	861 1200	1201 1600
L W larghezza width	600-910	A1	B1	C1	D1
	911-1110	A2	B2	C2	D2
	1111-1470	A3	B3	C3	D3
	1471-1860	A4	B4	C4	D4

Specificare all'ordine misure cava ferramenta
Specify hardware slot size

		H altezza - Height			
AG1274		350 660	661 860	861 1200	1201 1400
L W larghezza width	560-660	A1	B1	C1	D1
	661-860	A2	B2	C2	D2
	861-1200	A3	B3	C3	D3
	1201-1600	A4	B4	C4	D4

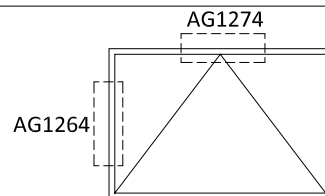

2 cerniere - peso massimo anta 70 kg
3 cerniere - peso massimo anta 100 kg

2 hinges - maximum leaf weight 70 kg
3 hinges - maximum leaf weight 100 kg

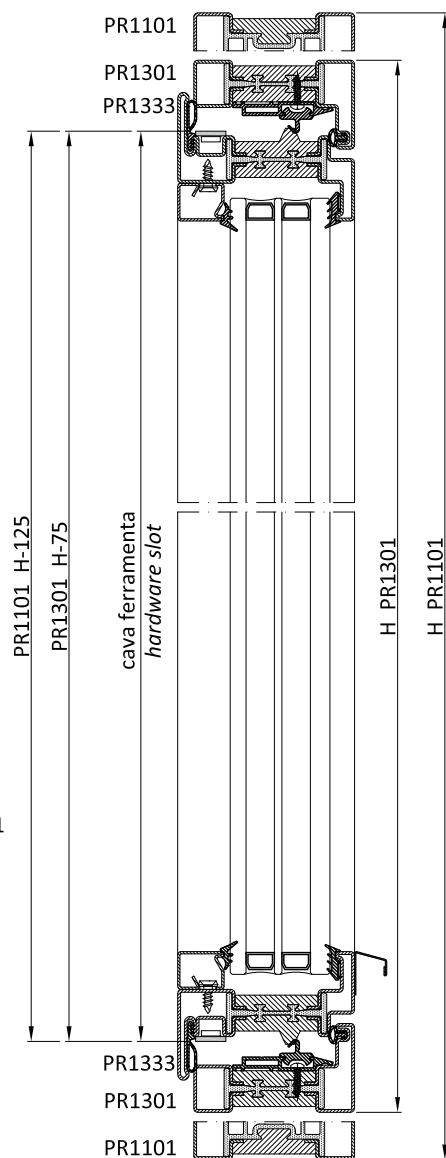
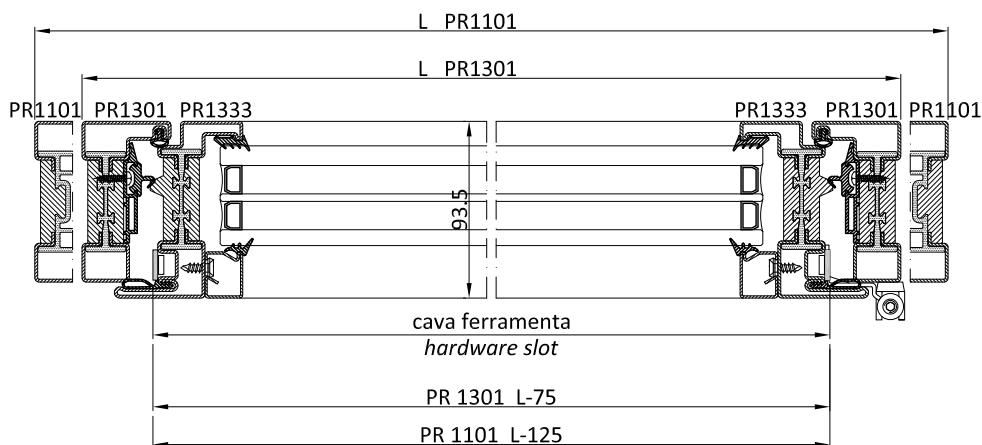

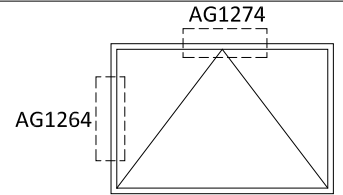

Fori per inserimento quadro comando e fissaggio maniglia / movimento DK
holes for inserting control panel and anchoring of handle / TT (tilt and turn) movement

Asola per inserimento meccanismo cremonese
Slot for insertion of cremone mechanism

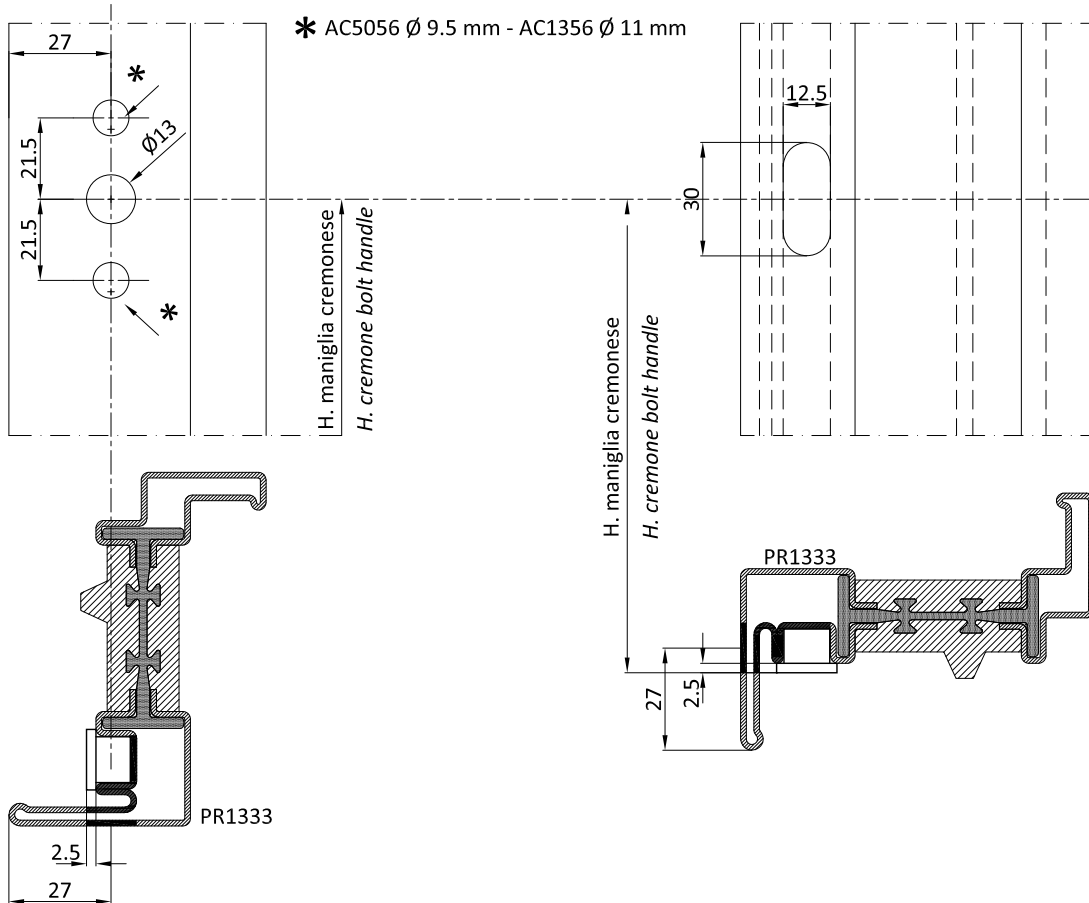

AG1264 ALTEZZA MANIGLIA CREMONESE - CREMONE BOLT HANDLE HEIGHT		
Tipo Type	cava ferramenta hardware slot	H maniglia cremonese H cremone bolt handle
Vasistas Bottom-hung	560 → 660	H/2
	661 → 860	H/2
	861 → 1200	H/2
	1201 → 1600	H/2

AG1274 ALTEZZA MANIGLIA CREMONESE - CREMONE BOLT HANDLE HEIGHT		
Tipo Type	cava ferramenta hardware slot	H maniglia cremonese H cremone bolt handle
Vasistas Bottom-hung	560 → 660	L/2
	661 → 860	L/2
	861 → 1200	L/2
	1201 → 1600	L/2

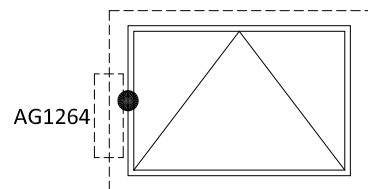

2 cerniere - peso massimo anta 70 kg
3 cerniere - peso massimo anta 100 kg

2 hinges - maximum leaf weight 70 kg
3 hinges - maximum leaf weight 100 kg

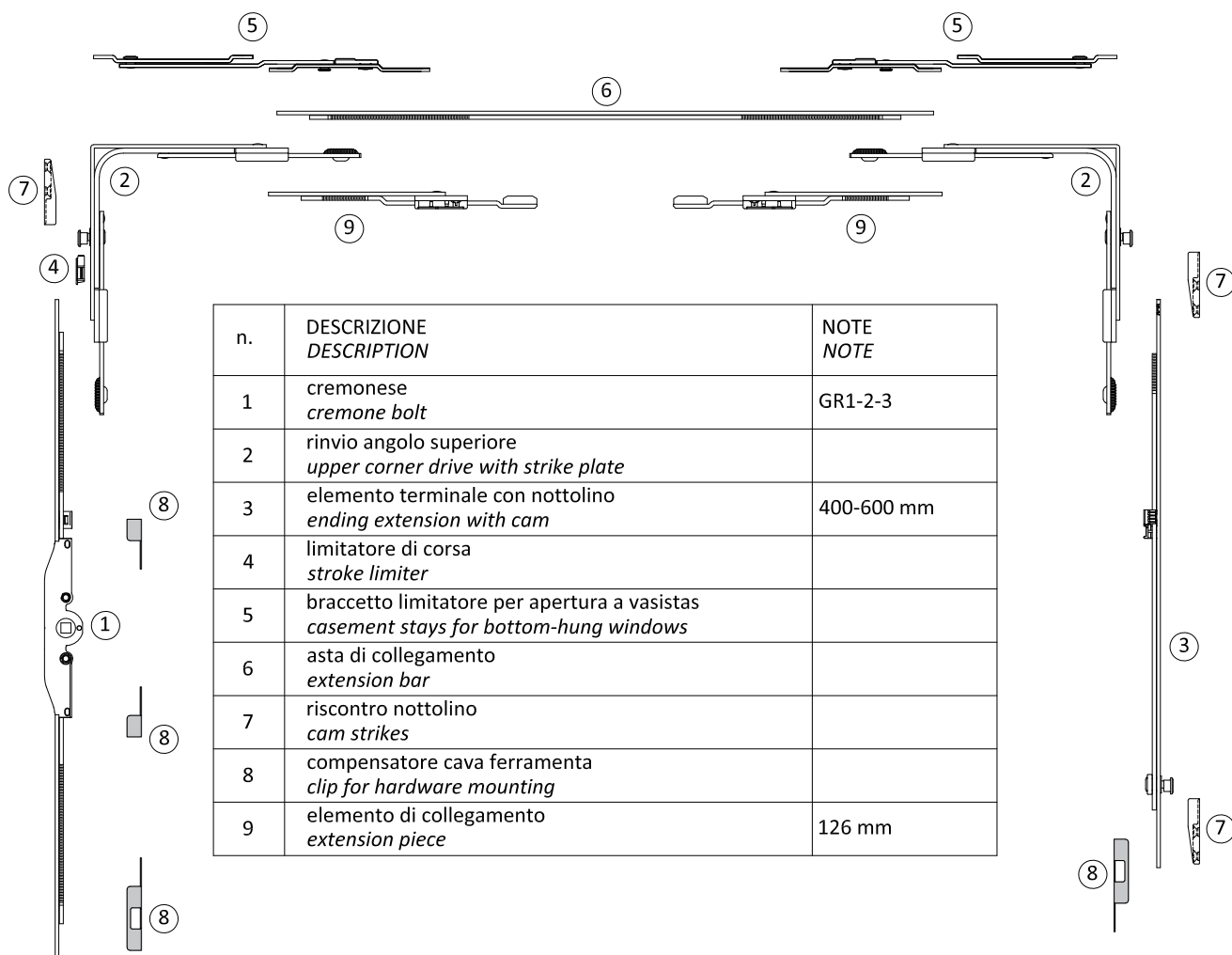

n.	DESCRIZIONE DESCRIPTION	NOTE NOTE
1	cremonese cremone bolt	GR1-2-3
2	rinvio angolo superiore upper corner drive with strike plate	
3	elemento terminale con nottolino ending extension with cam	400-600 mm
4	limitatore di corsa stroke limiter	
5	braccetto limitatore per apertura a vasistas casement stays for bottom-hung windows	
6	asta di collegamento extension bar	
7	riscontro nottolino cam strikes	
8	compensatore cava ferramenta clip for hardware mounting	
9	elemento di collegamento extension piece	126 mm

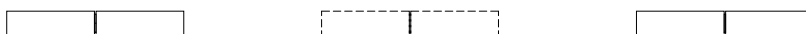

AC1221
AC2632/C
AG1224

cerniere non incluse nel kit
hinges not included in the kit

Specificare all'ordine misure cava ferramenta
Specify hardware slot size



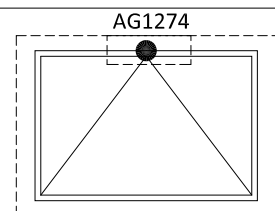

2 cerniere - peso massimo anta 70 kg
3 cerniere - peso massimo anta 100 kg

2 hinges - maximum leaf weight 70 kg
3 hinges - maximum leaf weight 100 kg

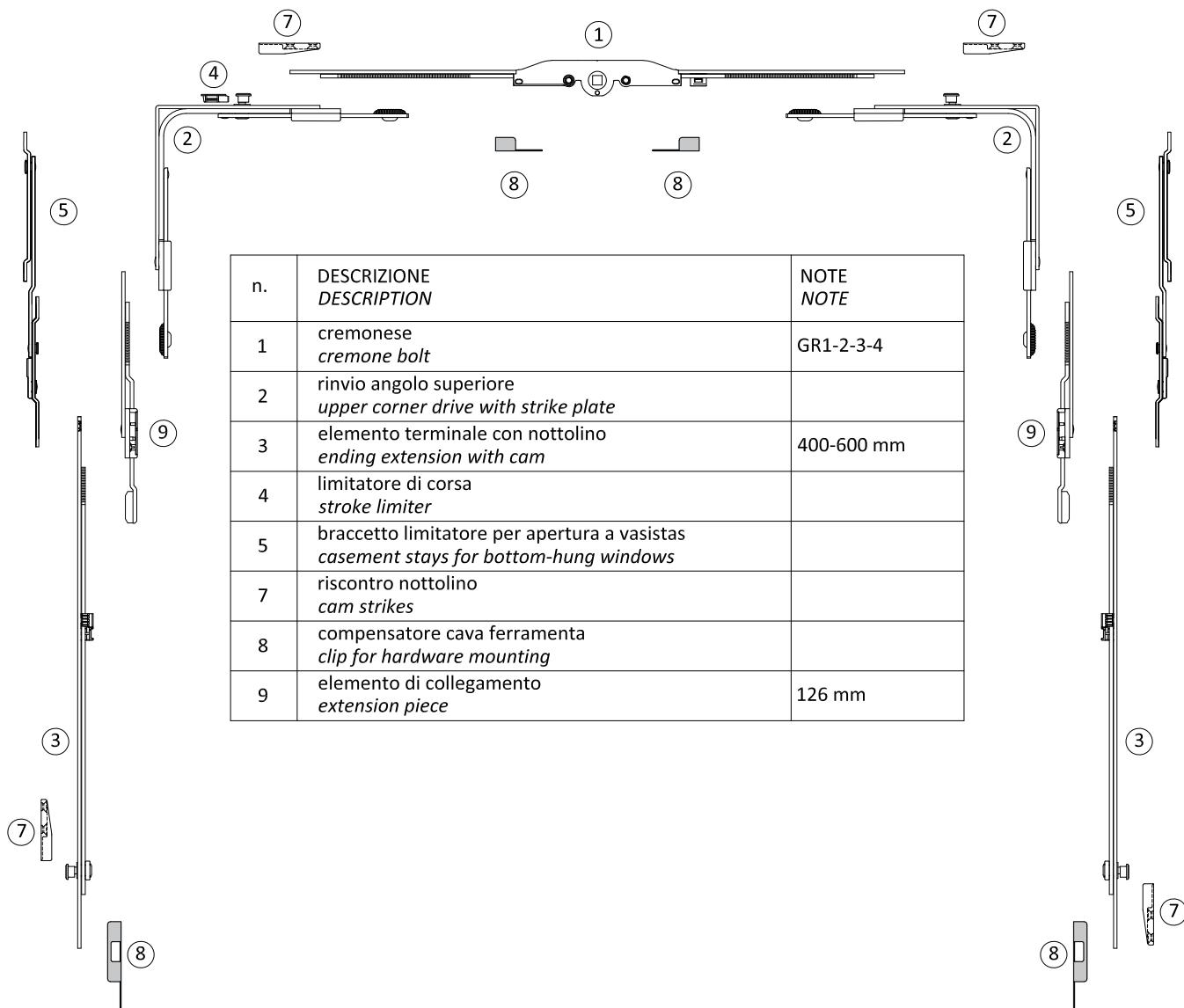

n.	DESCRIZIONE DESCRIPTION	NOTE NOTE
1	cremonese <i>cremone bolt</i>	GR1-2-3-4
2	rinvio angolo superiore <i>upper corner drive with strike plate</i>	
3	elemento terminale con nottolino <i>ending extension with cam</i>	400-600 mm
4	limitatore di corsa <i>stroke limiter</i>	
5	braccetto limitatore per apertura a vasistas <i>casement stays for bottom-hung windows</i>	
7	riscontro nottolino <i>cam strikes</i>	
8	compensatore cava ferramenta <i>clip for hardware mounting</i>	
9	elemento di collegamento <i>extension piece</i>	126 mm

AC1221
AC2632/C
AG1224

cerniere non incluse nel kit
hinges not included in the kit



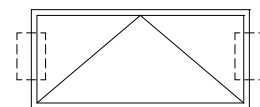
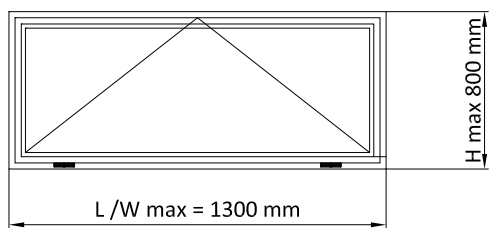

Peso max. per anta 70 Kg
H min anta 300 mm
Max. weight for leaf: 70 kg
W min leaf 300 mm

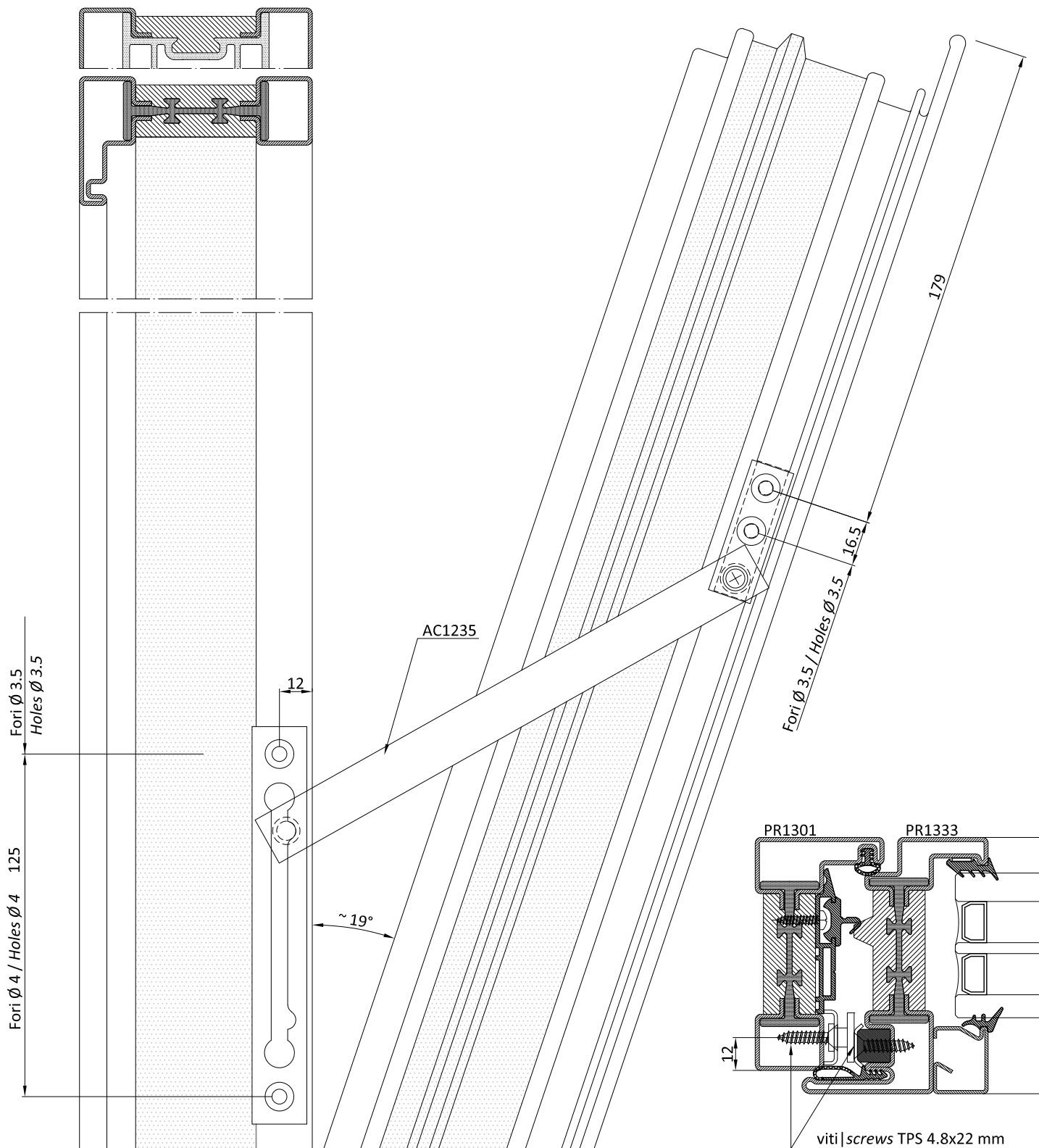

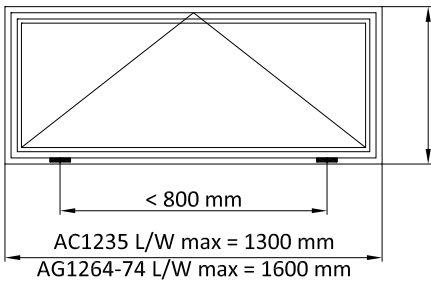

AC1235 H max = 800 mm
AG1264-74 H max = 1200 mm

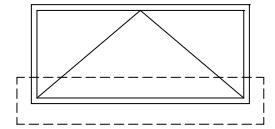

AC1235
Peso max. per anta 70 kg
Max. weight for leaf: 70 kg

AG1264 - AG1274
2 cerniere
peso massimo anta 70 kg
3 cerniere
peso massimo anta 100 kg

2 hinges
maximum leaf weight 70 kg
3 hinges
maximum leaf weight 100 kg

GE1200TT - tagliare la guarnizione dove interseca le cerniere
GE1200TT - cut the gasket where the hinges cross

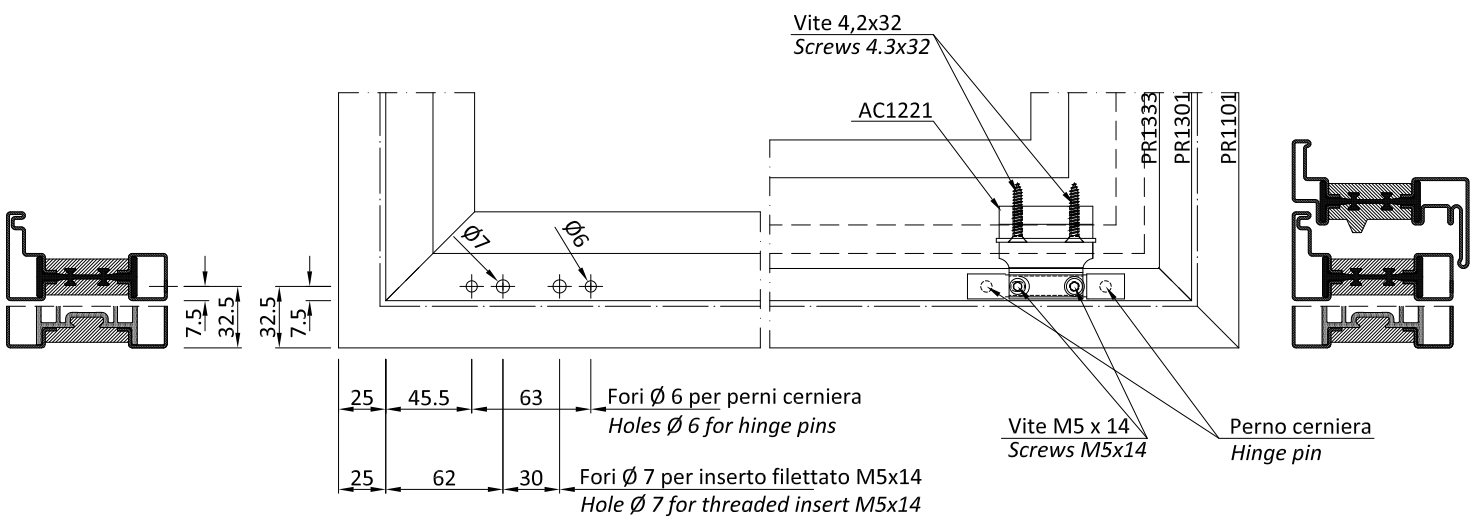
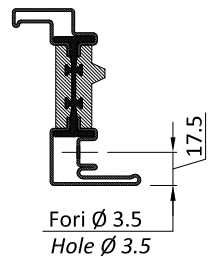
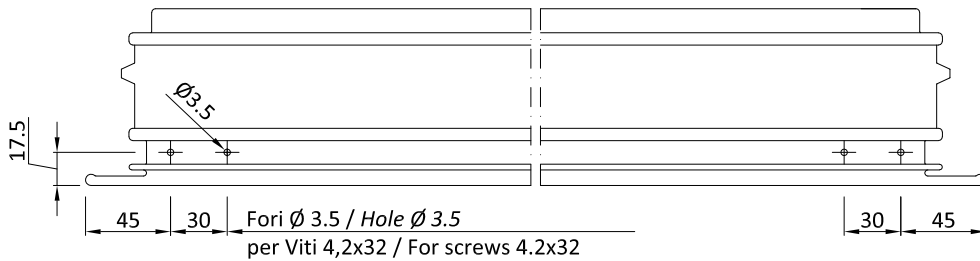
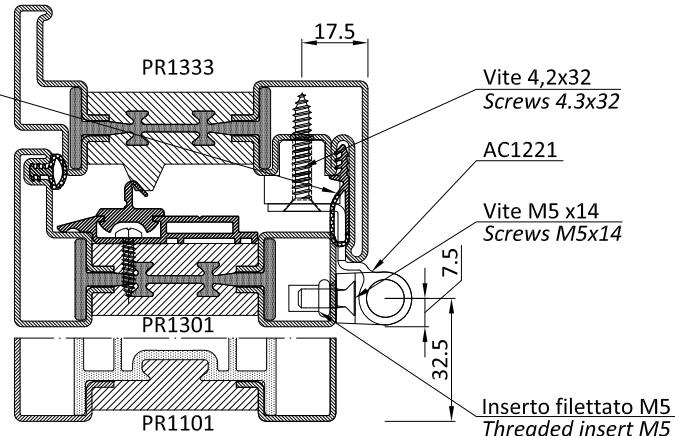

Viti non fornite
Screws not supplied



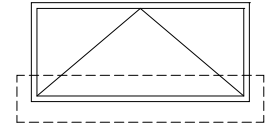
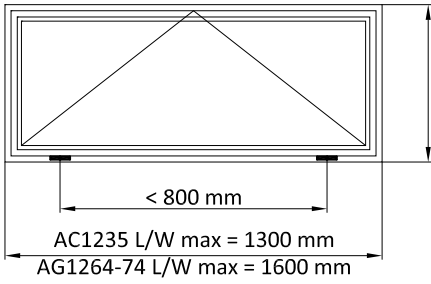

AC1235
Peso max. per anta 70 kg
Max. weight for leaf: 70 kg

AG1264 - AG1274
2 cerniere
peso massimo anta 70 kg
3 cerniere
peso massimo anta 100 kg

2 hinges
maximum leaf weight 70 kg
3 hinges
maximum leaf weight 100 kg

GE1200TT - tagliare la guarnizione dove interseca le cerniere
GE1200TT - cut the gasket where the hinges cross

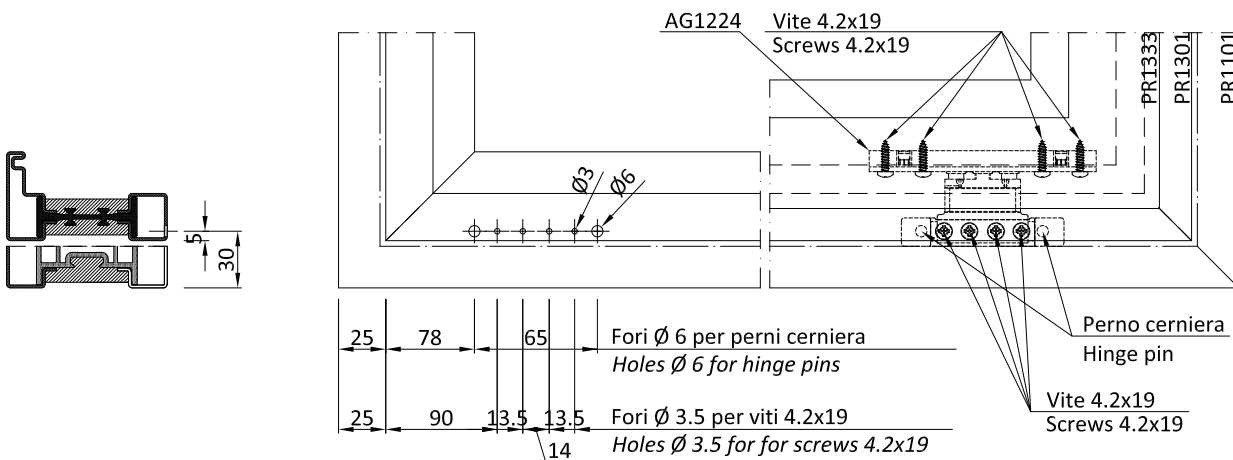
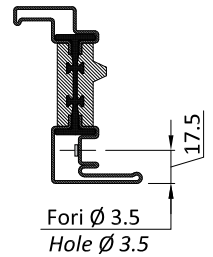
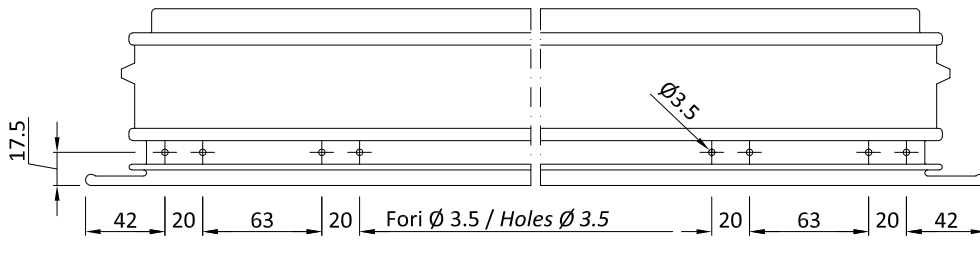
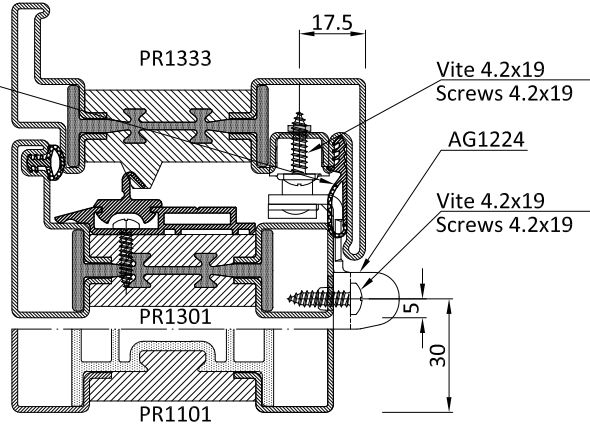

Viti non fornite
Screws not supplied



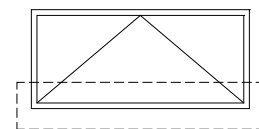
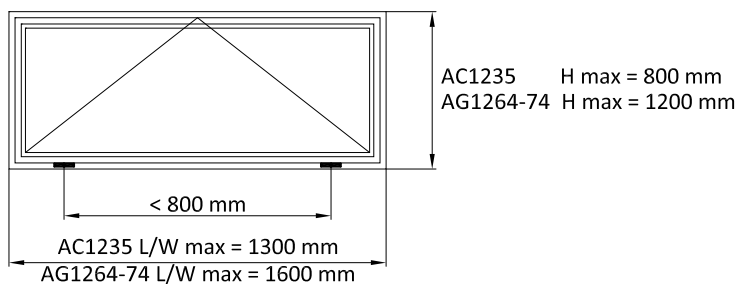

AC1235
Peso max. per anta 70 kg
Max. weight for leaf: 70 kg

AG1264 - AG1274
2 cerniere
peso massimo anta 70 kg
3 cerniere
peso massimo anta 100 kg

2 hinges
maximum leaf weight 70 kg
3 hinges
maximum leaf weight 100 kg

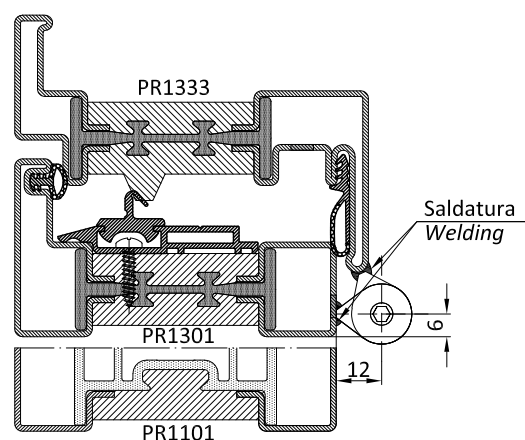

Posizionare le cerniere come da disegno saldandole sui lati.
Position the hinges as in the drawing, welding them on the sides.

- La lavorazione può essere effettuata anche in posizioni intermedie alla larghezza del vasistas.
- La lavorazione SX è speculare alla DX.

- Tooling can be carried out also in intermediate positions regarding the width of the hopper or bottom-hung window.
- Tooling on left is the same as that on the right.

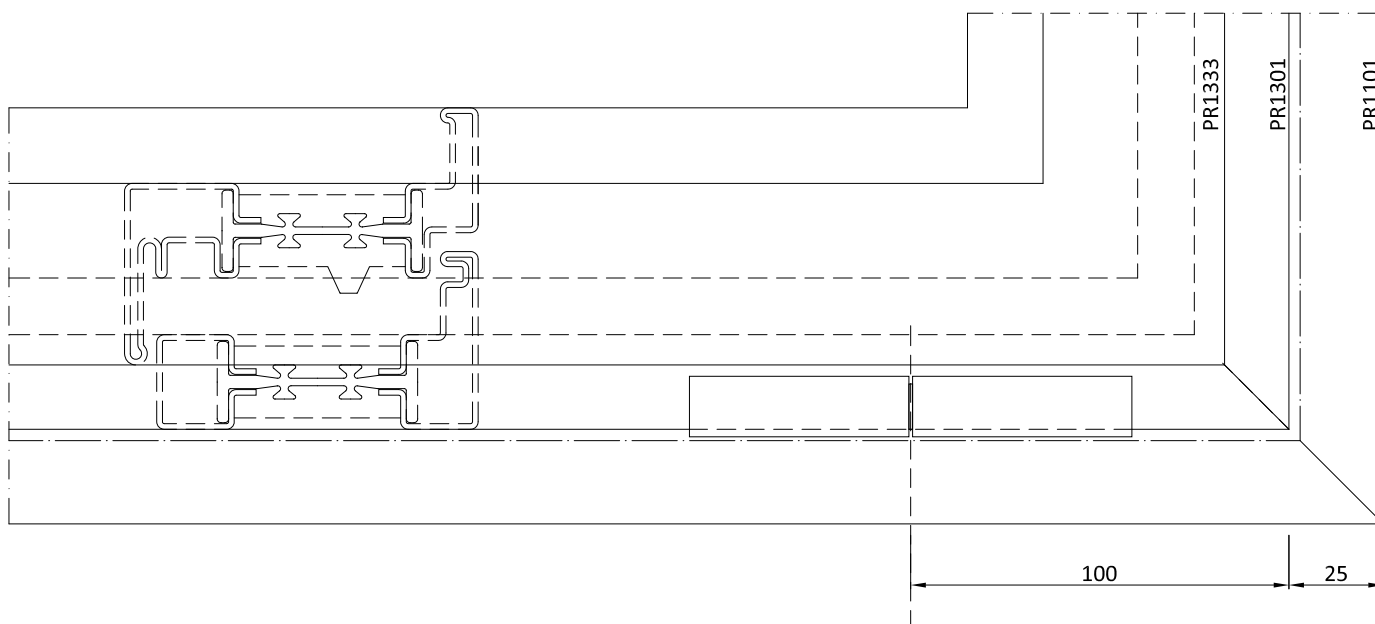

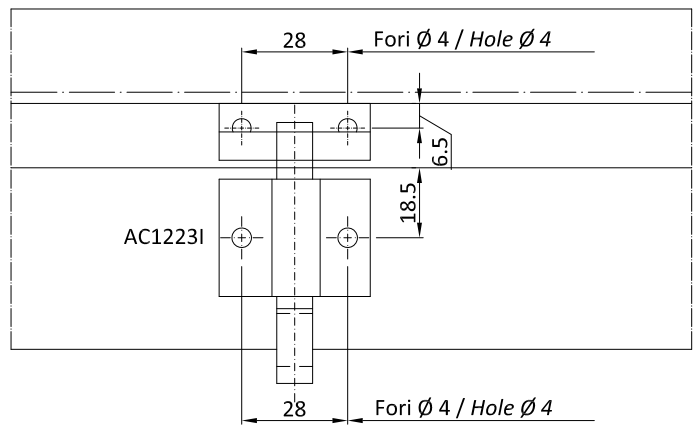
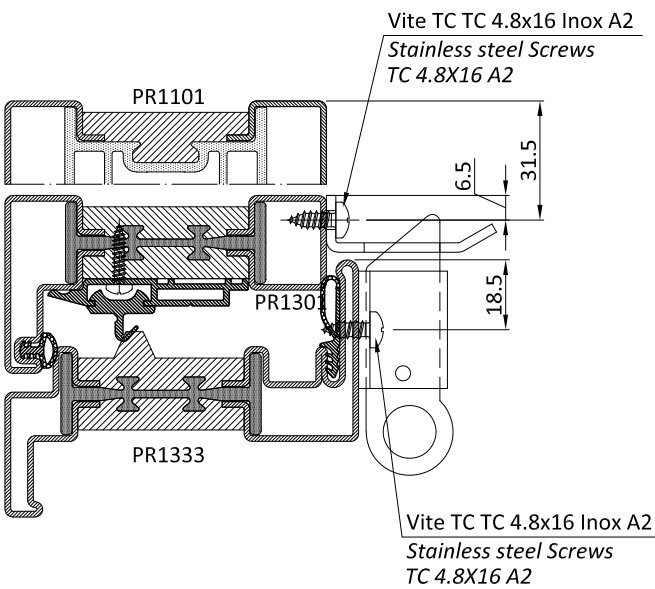
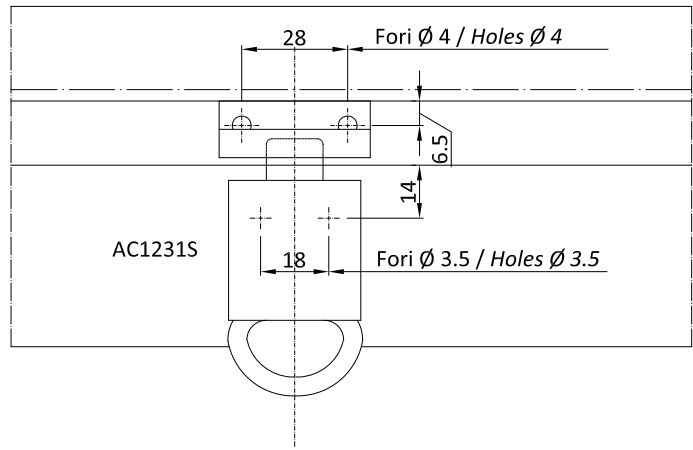
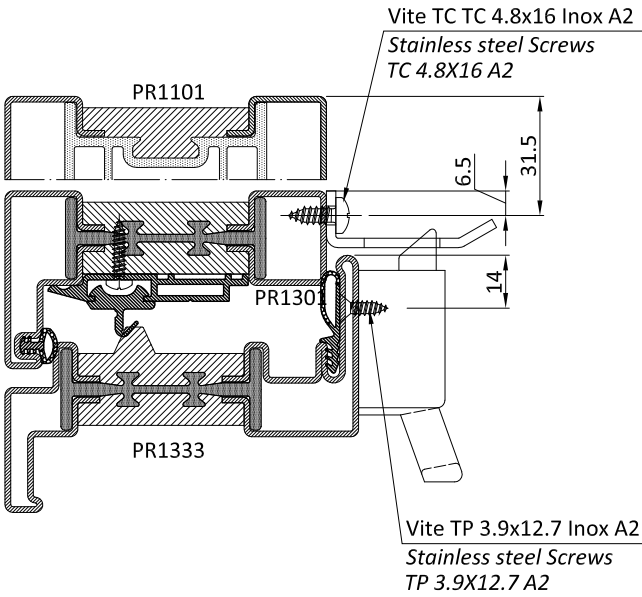
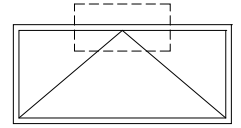
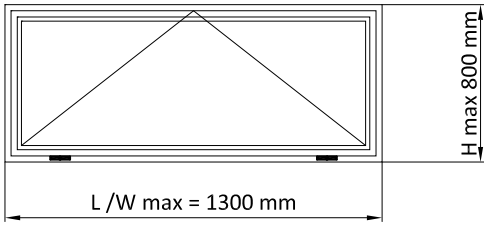

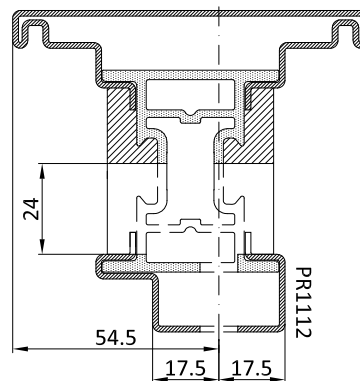
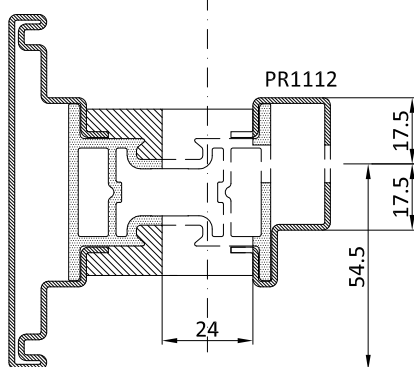
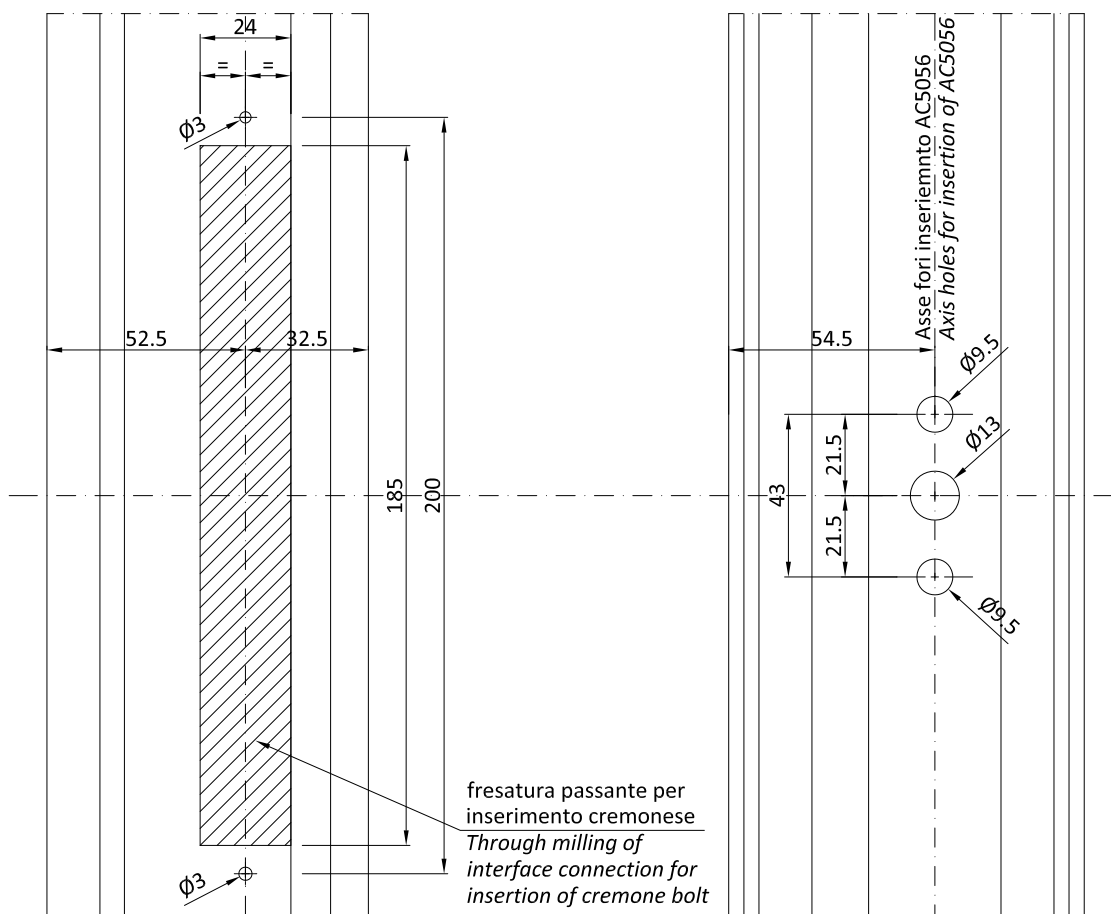
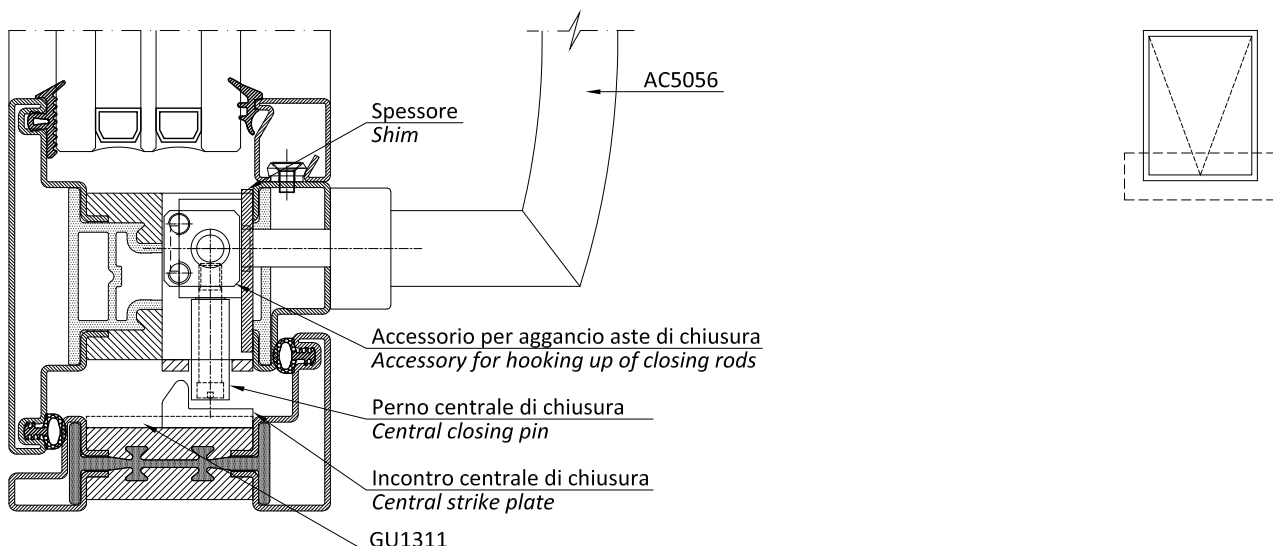

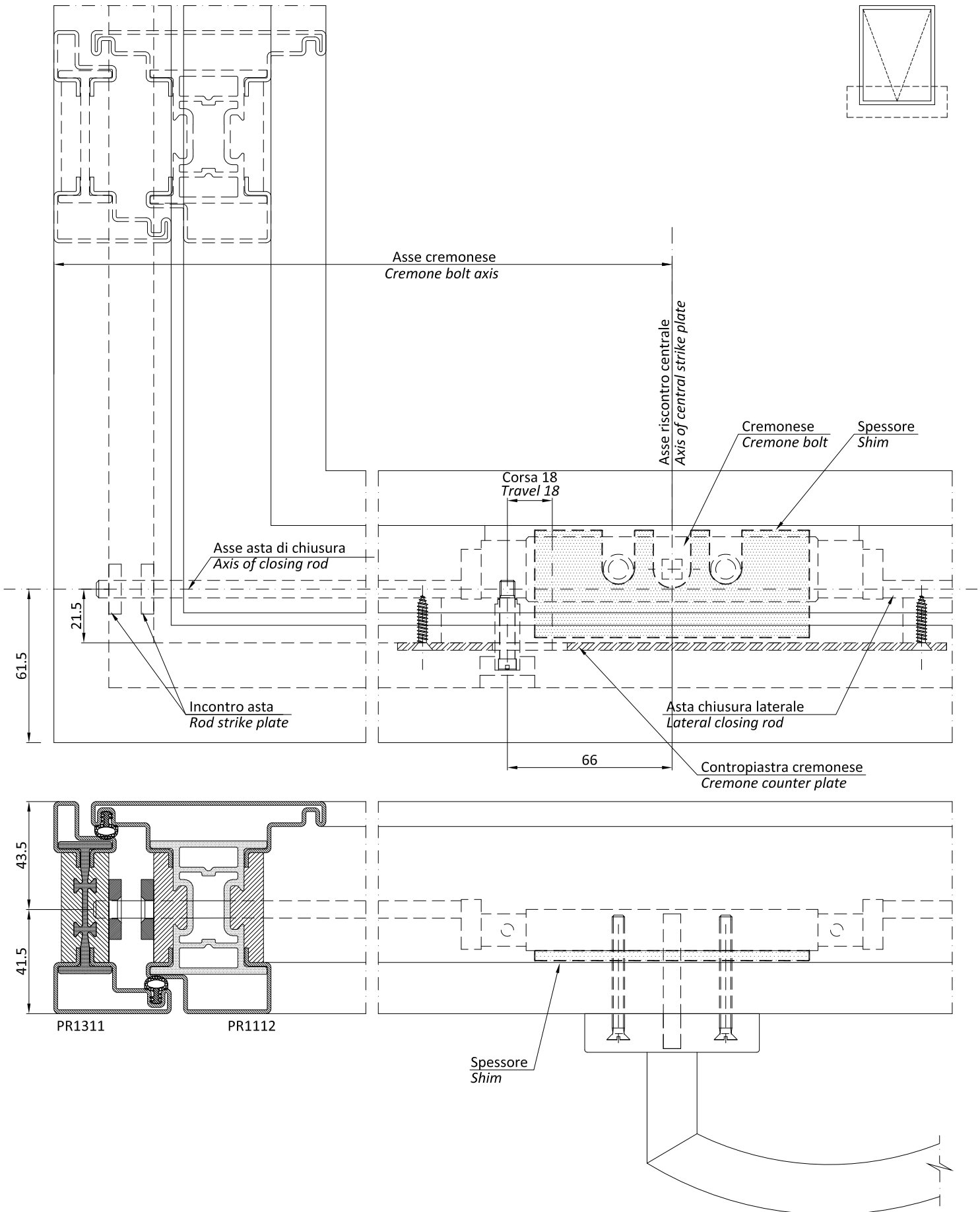

Peso massimo anta 75 kg
Maximum vent weight 75 kg

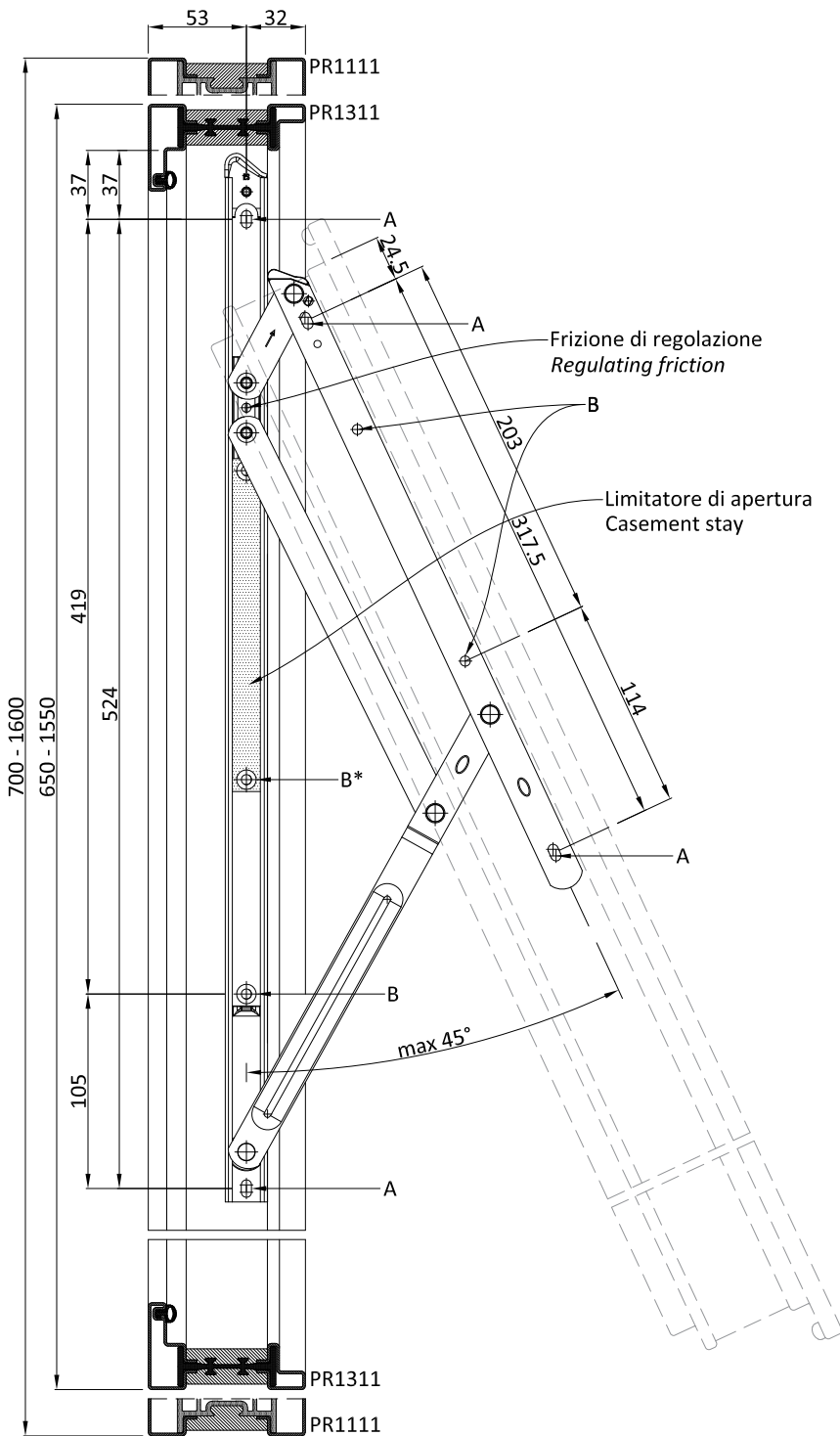
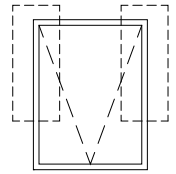

- Fissare i compassi in corrispondenza dei fori asolati A foro su profilo Ø 4 per viti TC 4.8x22 mm;
- Verificare il funzionamento dei compassi;
- Fissare l'apertura massima desiderata mediante il limitatore di apertura;
- Completare l'operazione di fissaggio nei rimanenti fori B.

* posizione determinata dalla apertura massima desiderata - foro da eseguire in opera

- Fit the side arms into the slotted holes A - hole on profile Ø 4 for TC 4.8x22 mm screws;
- Check the side arms move properly;
- Set the desired maximum opening using the casement stay;
- Complete the anchoring operation in the remaining B holes.

* Position determined by the maximum opening desired - hole to be made during installation

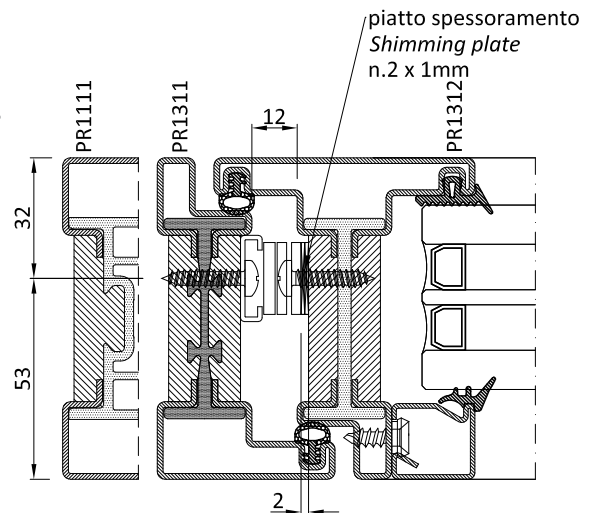

Peso massimo anta 120 kg
Maximum vent weight 120 kg

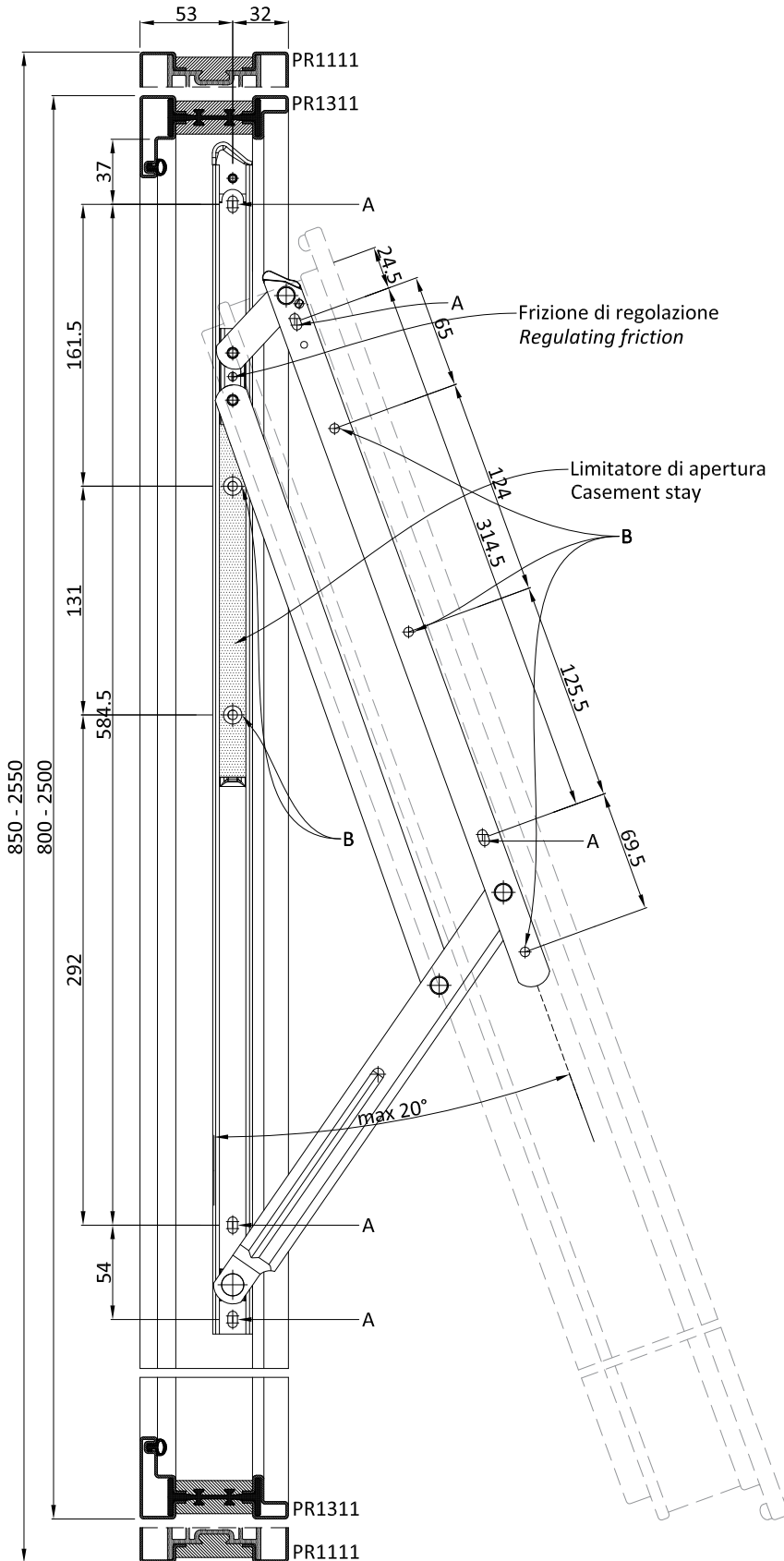
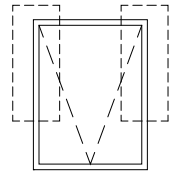

- Fissare i compassi in corrispondenza dei fori asolati A foro su profilo Ø 4 per viti TC 4.8x22 mm;
- Verificare il funzionamento dei compassi;
- Fissare l'apertura massima desiderata mediante il limitatore di apertura;
- Completare l'operazione di fissaggio nei rimanenti fori B.

* posizione determinata dalla apertura massima desiderata - foro da eseguire in opera

- Fit the side arms into the slotted holes A - hole on profile Ø 4 for TC 4.8x22 mm screws;
- Check the side arms move properly;
- Set the desired maximum opening using the casement stay;
- Complete the anchoring operation in the remaining B holes.

* Position determined by the maximum opening desired - hole to be made during installation

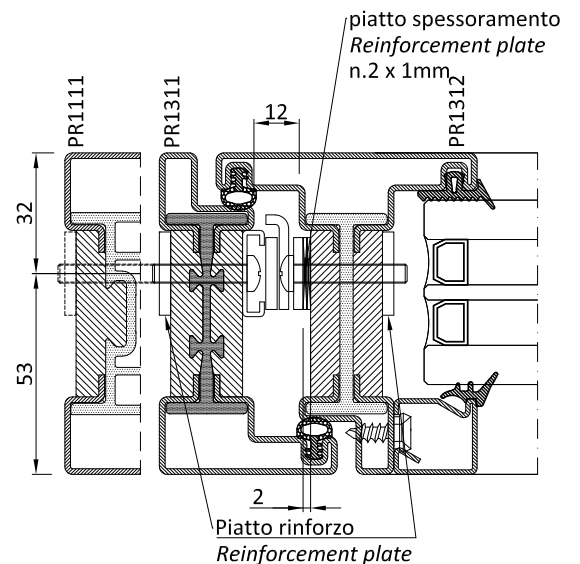

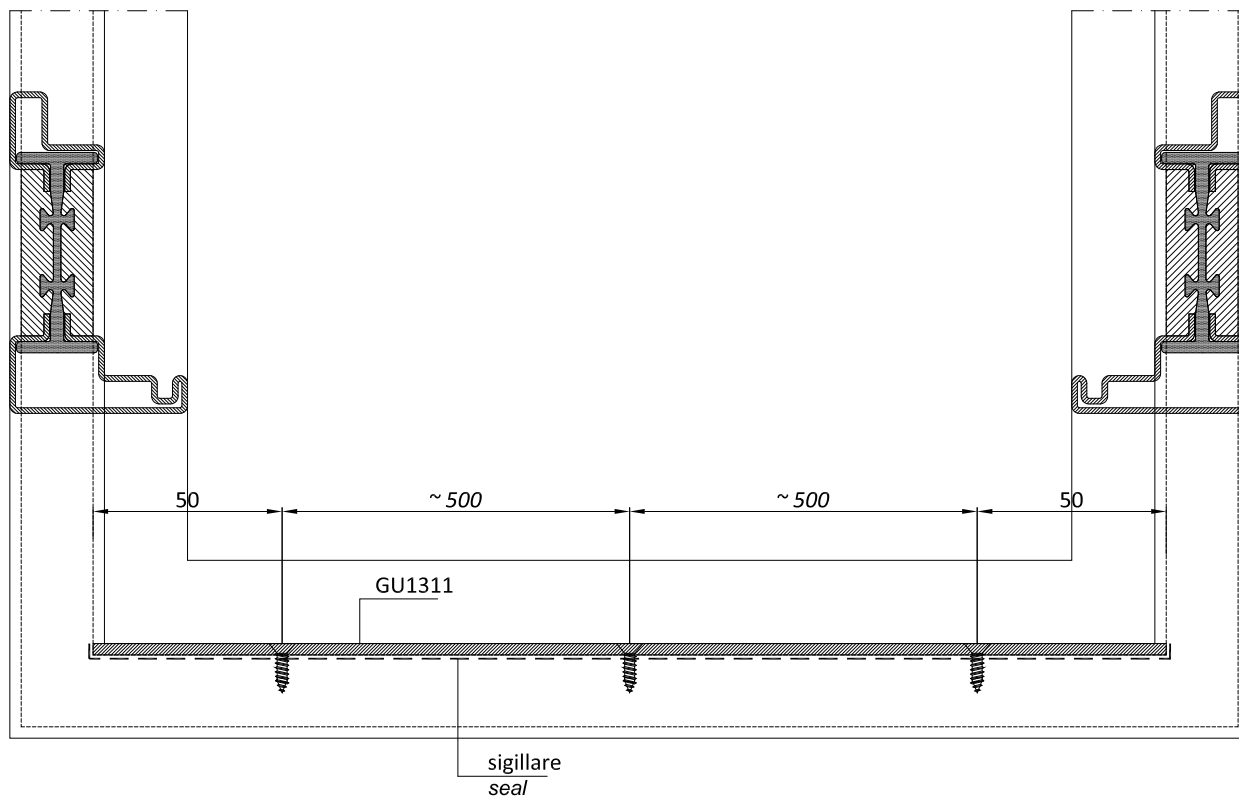
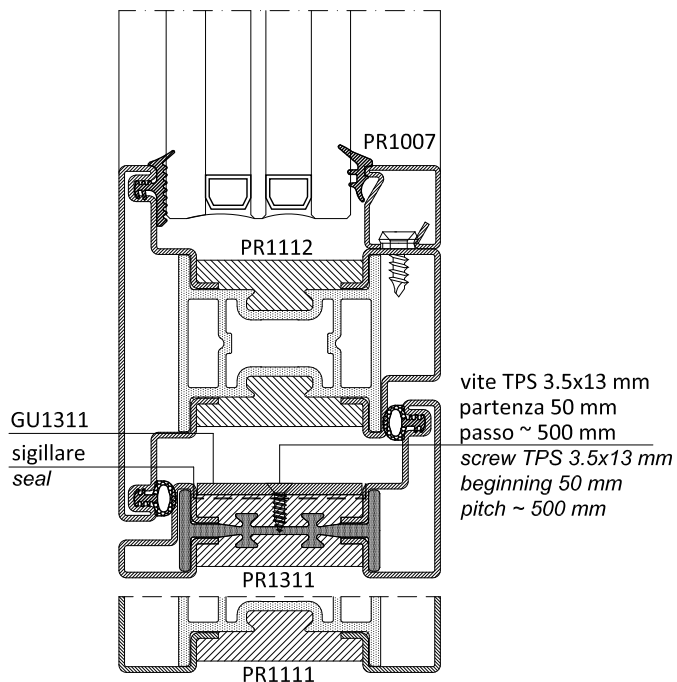
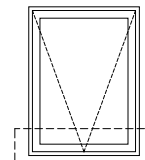

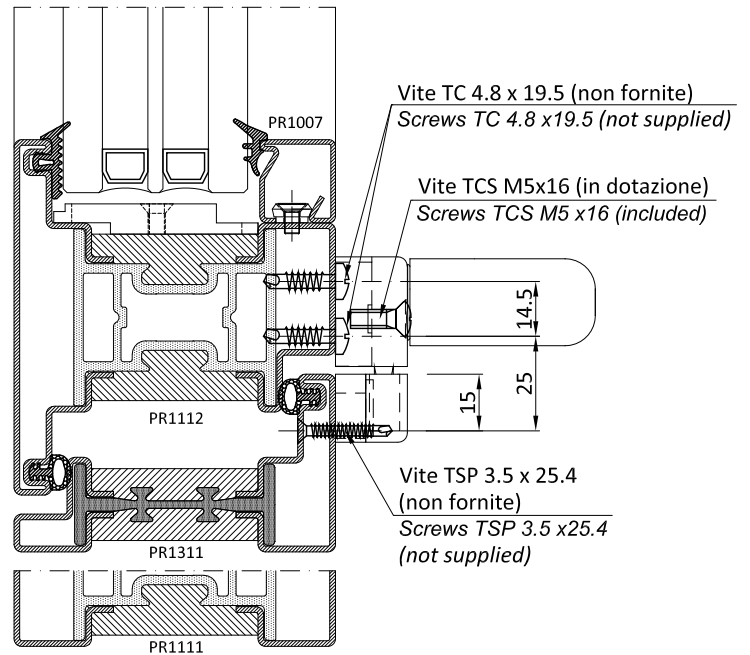
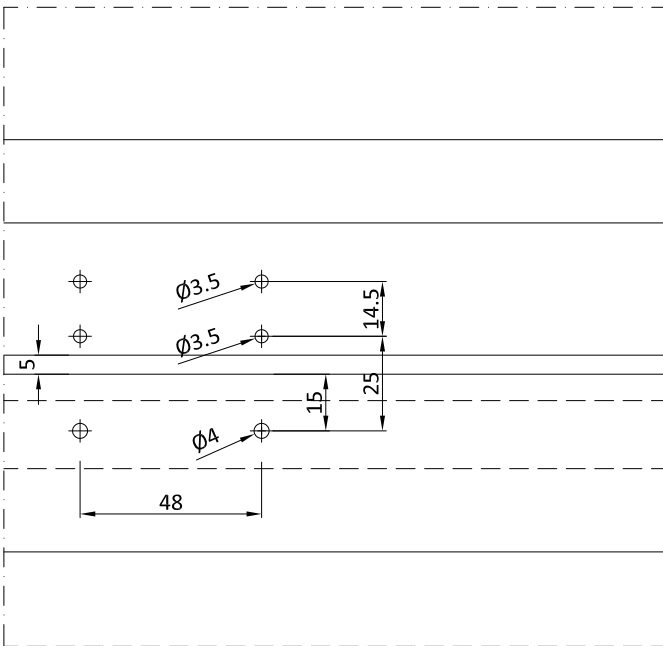
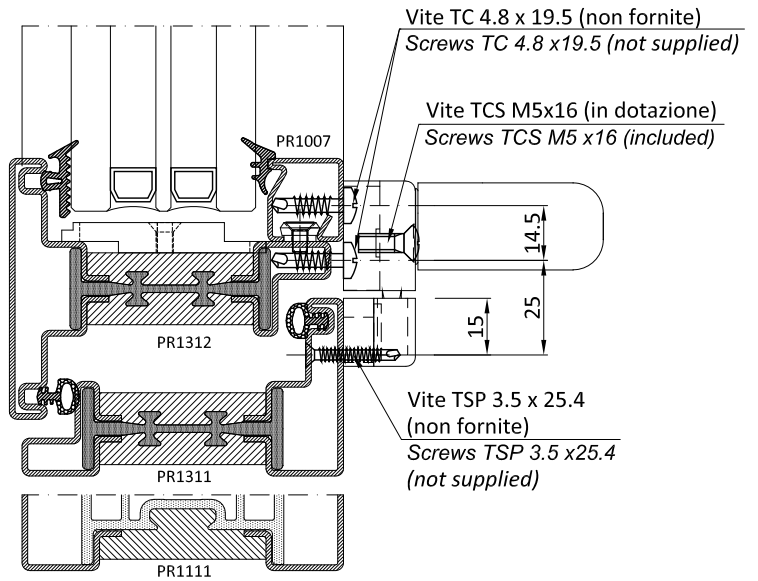
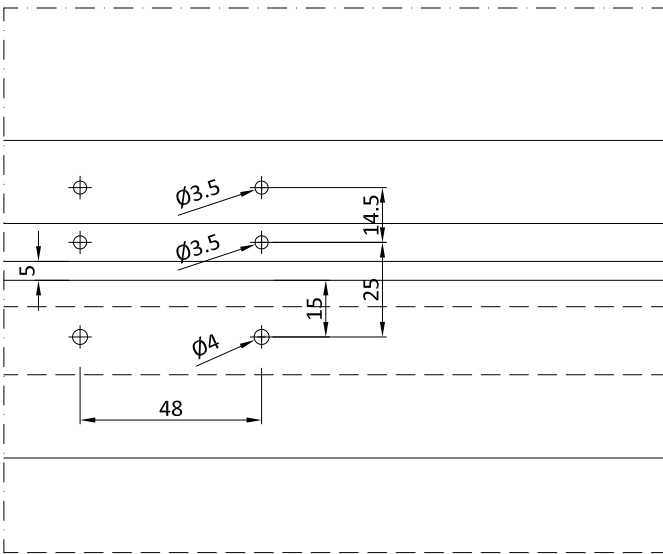
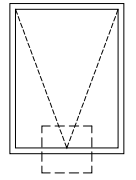
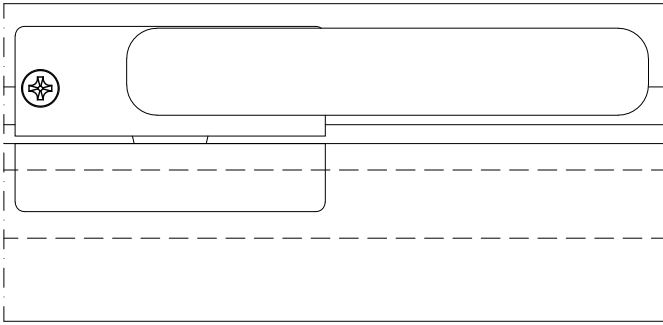

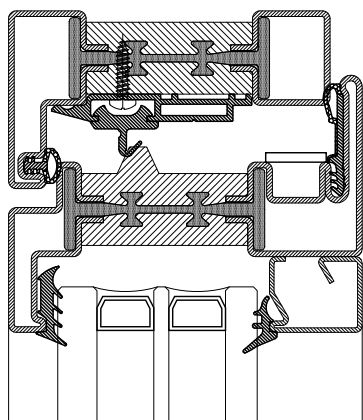
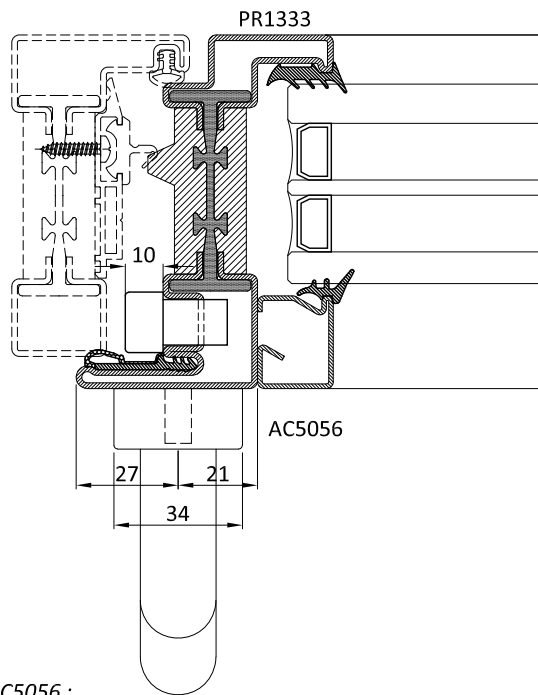
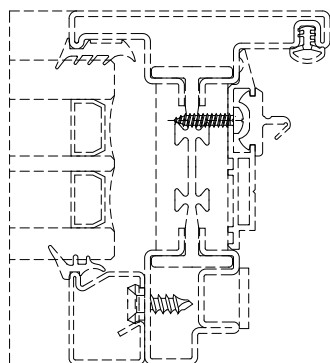
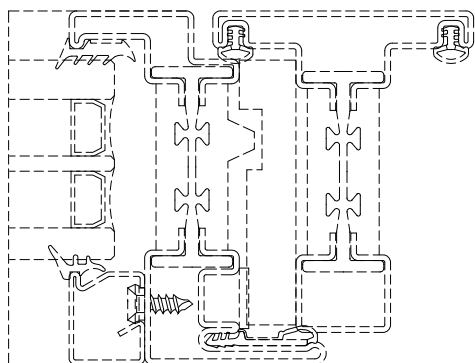
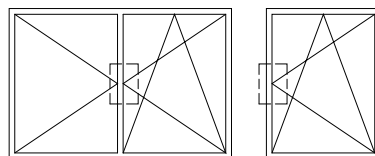

AC5056 :

- 1) Impugnatura
- 2) Rosetta
- 3) Corpo maniglia
- 4) Quadro
- 5) Vite TP M5x50 (non fornite)

AC5056 :

- 1) Handle grip
- 2) Rose
- 3) Handle body
- 4) Spindle bar
- 5) Flat head screws M5x50 (not supplied)

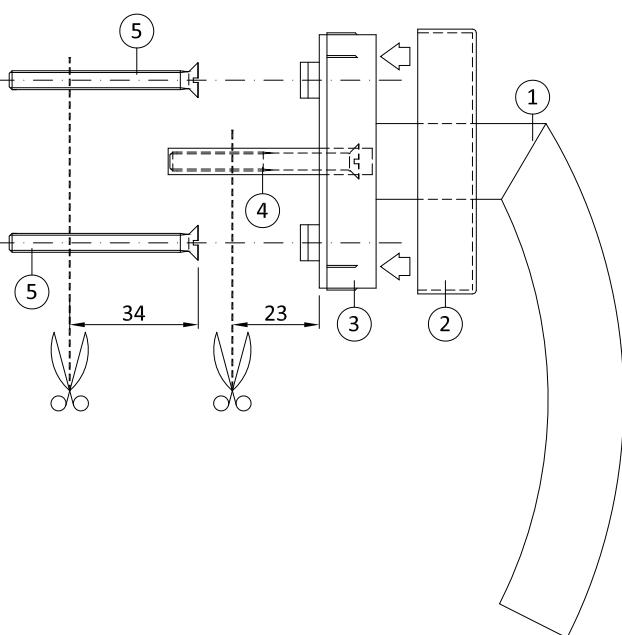
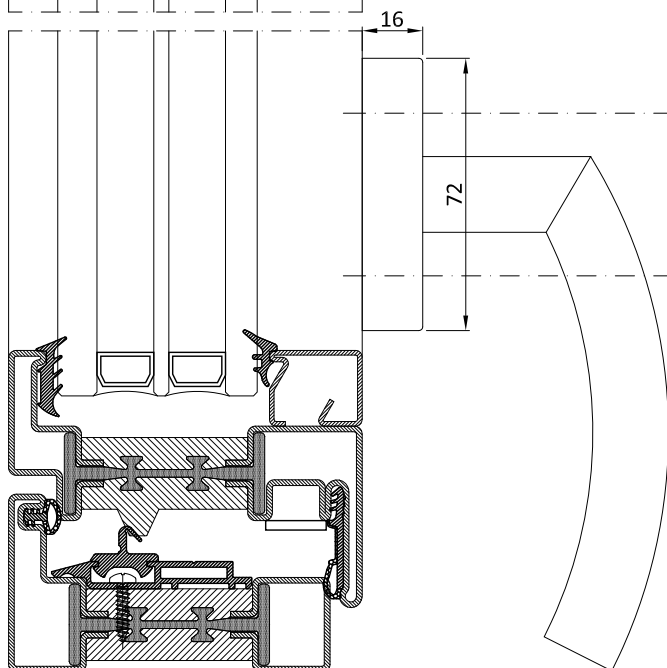

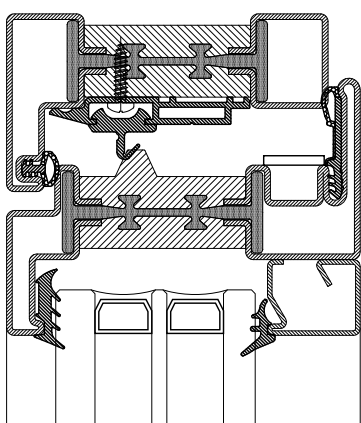
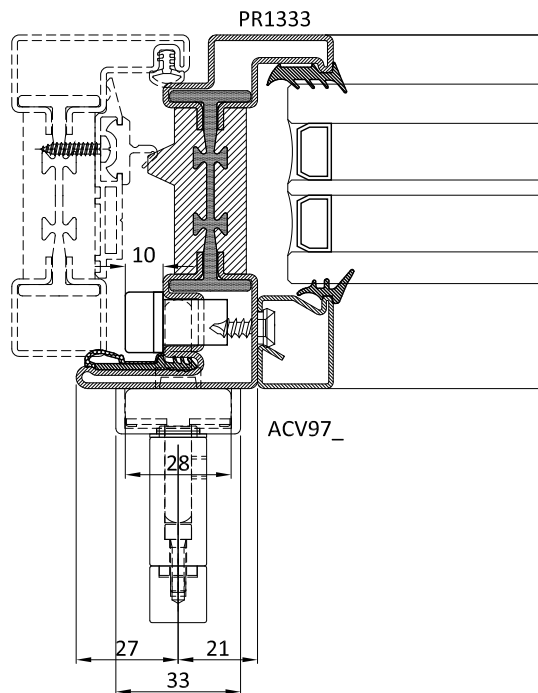
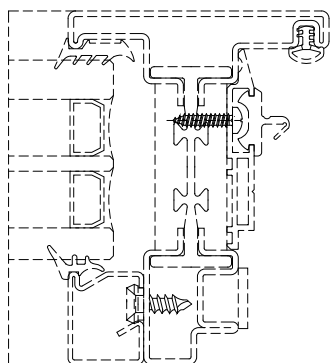
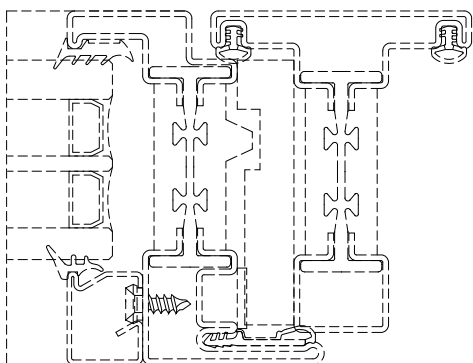
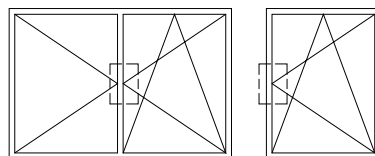

ACV97- :

- 1) Impugnatura
- 2) Rondella
- 3) Rosetta
- 4) Grano M6x6
- 5) Vite TP M5x50 (non fornite)
- 6) AC1356 Movimento DK

ACV97- :

- 1) Handle grip
- 2) Ring
- 3) Rose
- 4) Dowel M6x6
- 5) Flat head screws M5x50 (not supplied)
- 6) Tilt-turn movement AC1356

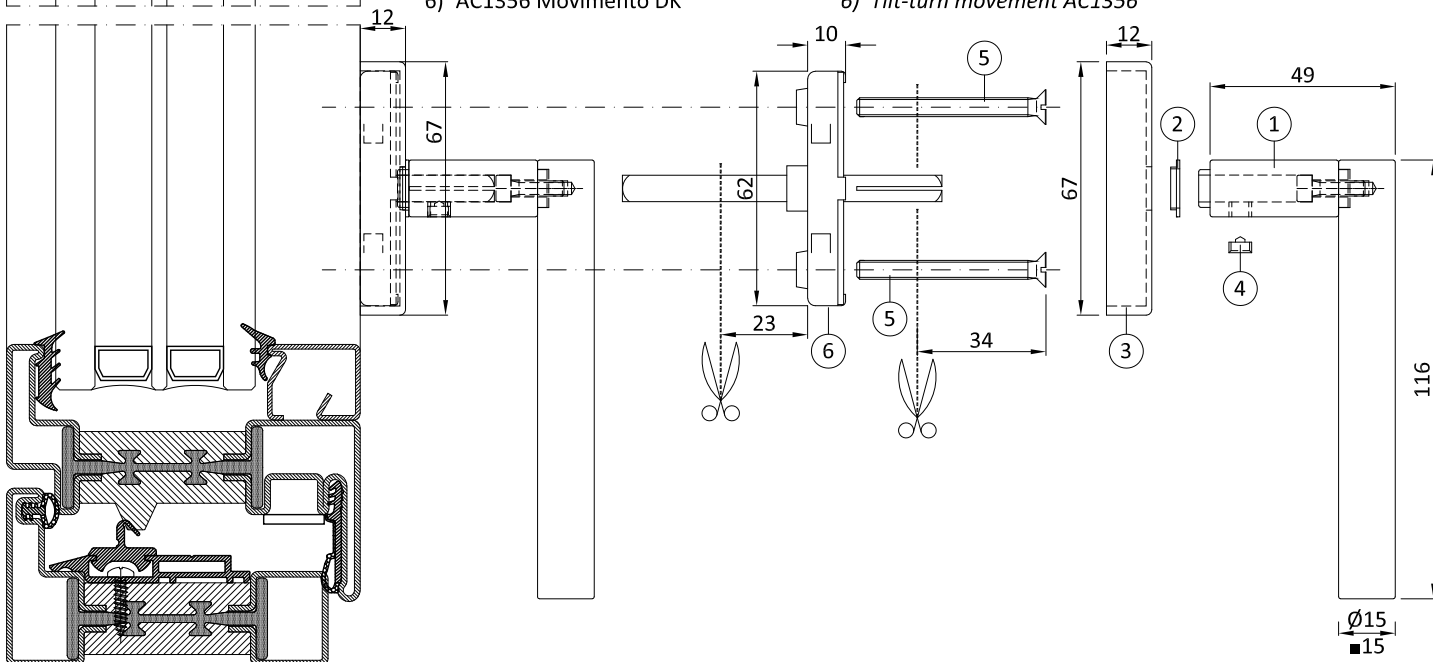

Finestra | Window

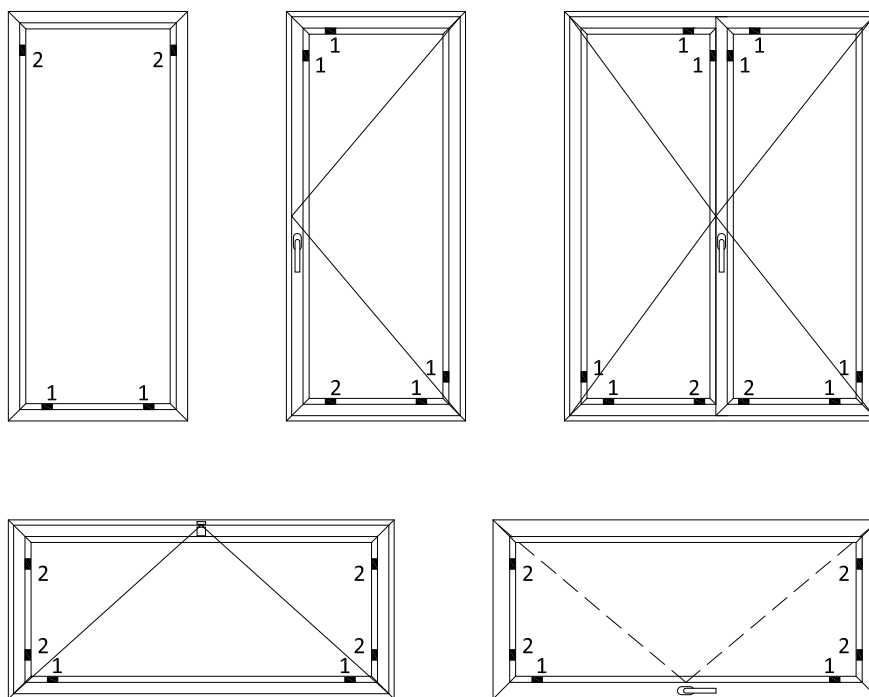

- 1) spessore portante | carry shim
- 2) spessore distanziatore | compensation shim

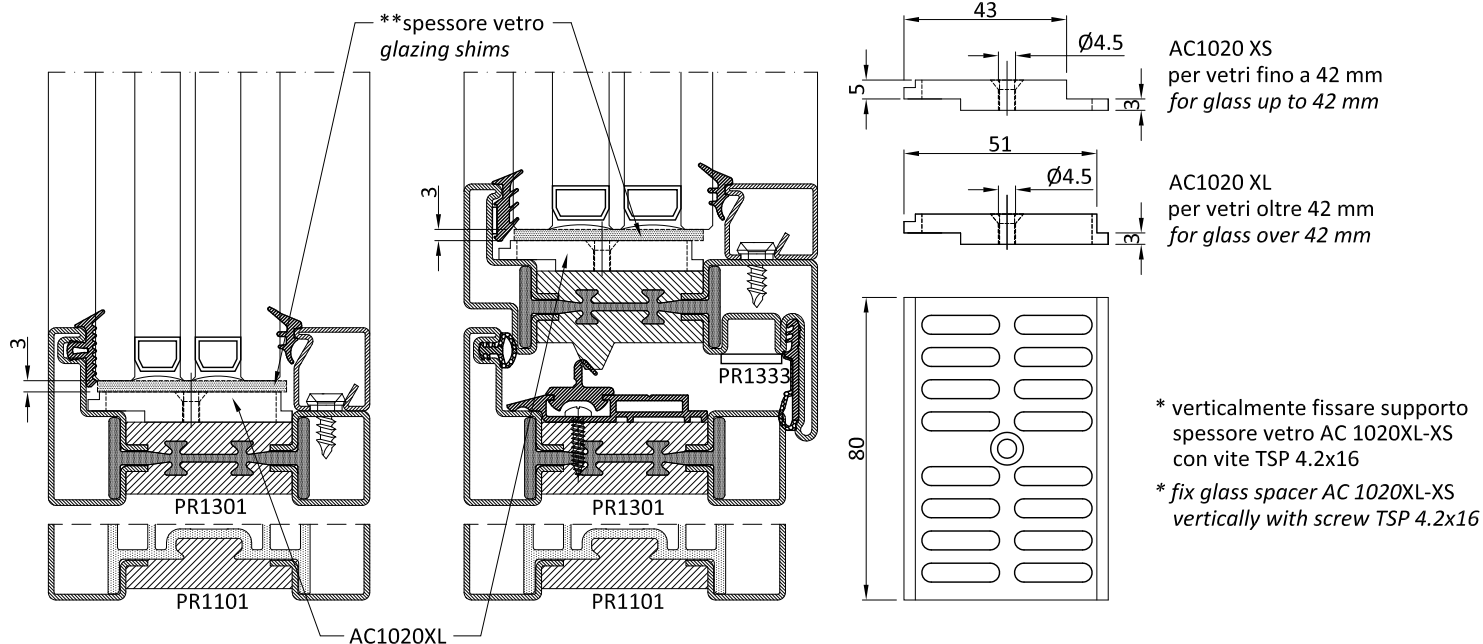

Note / Note

- La larghezza degli spessori è almeno pari o maggiore (+2 mm) dello spessore del vetro installato.
- La posizione degli spessori deve essere garantita dall'utilizzo di materiale adeguato che ne eviti lo spostamento.
- The shims' width is the same or greater (+2 mm) than the thickness of the glass installed.
- The position of the shims has to be ensured by using appropriate material that avoids creeping.

* vite TSP 4.2 x 16 mm non inclusa - screw TSP 4.2 x 16 mm not included

** spessori vetro non inclusi - glass thickness not included



Generalità

I sistemi progettati e sviluppati dalla Secco Sistemi sono idonei per la fabbricazione di un'ampia gamma serramenti, vetrate e facciate in metallo. I sistemi sono rivolti ad aziende esperte e professionali nel campo della lavorazione dei metalli e della costruzione di serramenti e facciate, che sono a conoscenza delle normative di riferimento, delle direttive e delle specifiche tecniche del fornitore del sistema, nonché delle fondamentali regole dell'arte per la produzione e installazione di questi manufatti. Tutta la documentazione tecnica fornita costituisce un riferimento per i tecnici qualificati delle aziende al fine di indicare le modalità per la costruzione dei prodotti. In ogni caso i tecnici qualificati devono analizzare criticamente le indicazioni riportate per verificarne la loro adeguatezza per ogni singola commessa in relazione ai carichi, agli stress previsti e alle condizioni di messa in opera, essendo impossibile riportare in questa documentazione tutte le varianti riscontrabili nei progetti reali.

Tolleranze

EBE 85 prevede l'accoppiamento tra i telai esterni e le ante apribili con distanza di 12 mm su porte e 15 mm su finestre. Per garantire il corretto funzionamento degli accessori e delle guarnizioni le lavorazioni devono essere eseguite con particolare attenzione e precisione: si consiglia di mantenere la tolleranza per la dimensione degli elementi apribili compresa tra +0/-2 mm e la tolleranza per il sormonto degli stessi compresa tra +0/+1 mm.

Taglio/Lavorazioni

I profili EBE 85 in acciaio zincato, acciaio inox e corten possono essere tagliati con le normali troncatrici a disco utilizzate per i tubolari in acciaio, mentre per il taglio dei profili in ottone possono anche essere utilizzate troncatrici per le serie di alluminio. Vista la loro particolare dimensione e forma si consiglia di utilizzare le ganasce di taglio previste dal sistema per assicurare una perfetta stabilità dei profili durante il taglio. La verifica del taglio, sia per la sezione inclinata a 45° che per la sezione verticale a 90°, dovrebbe garantire una tolleranza compresa tra -1°/+1°. Tutte le lavorazioni devono essere eseguite con il rispetto della seguente nota tecnica ed eventuali modifiche concordate con l'ufficio tecnico Secco Sistemi.

Saldatura

I profili EBE 85 possono essere saldati con i tradizionali sistemi di saldatura (MIG/MAG, TIG), con un idoneo sistema di lubrificazione/refrigerazione e utilizzando le istruzioni presenti nella presente nota tecnica ed evitando di saldare in prossimità della giunzione a taglio termico. L'eventuale riscaldamento del poliuretano libera sostanze gassose a base di aldeidi e CO: per tale ragione si consiglia di saldare con gli appositi DPI previsti e in zone con sufficiente areazione e in presenza di sistema per l'evacuazione dei fumi. I profili in corten devono essere saldati con apposito filo in corten mentre per i profili in ottone si può utilizzare un filo CuSi3. Si raccomanda di saldare in profondità e senza lasciare fori e porosità le aree in contatto, di lisciare e pulire adeguatamente la superficie saldata per garantire una corretta resistenza strutturale all'angolo e permettere una successiva verniciatura senza imperfezioni estetiche visibili (pori e ondulazioni).

Verniciatura/Brunitura

I profili EBE 85 sono stati progettati per essere verniciati a polveri in forni con temperature di 180°C per 25 minuti. La zona a taglio termico in poliuretano non è in grado di accogliere con sufficiente adesione le polveri poliesteri e perciò si consiglia di ricoprire tali zone, nelle sole parti destinate ad essere in vista, con apposite pellicole adesive idonee al passaggio in forno.

I telai prima della verniciatura o della brunitura devono essere forati come da istruzioni presenti in questa nota tecnica per permettere la fuoriuscita dei liquidi utilizzati durante il pretrattamento delle superfici. All'uscita del forno di polimerizzazione della polvere i telai vanno rimossi accuratamente e adagiati in posizione piana sino al loro completo raffreddamento. Si consiglia di seguire il ciclo di pretrattamenti e verniciatura presente nella documentazione Secco Sistemi.

Vetrazione

Il sistema di fissaggio del vetro prevede l'utilizzo di fermavetri agganciati all'interno tramite clips o boccole interne e mandati in pressione con l'incastro dell'apposita guarnizione interna; all'esterno è previsto l'utilizzo di una guarnizione perimetrale continua giuntata e sigillata in un angolo superiore o di una guarnizione butilica di fondo giunto e un cordolo di silicone applicato secondo le prescrizioni tecniche del fornitore del prodotto. Per il corretto funzionamento del sistema si suggerisce di verificare la perfetta compressione delle guarnizioni interne del fermavetro.

Installazione

La corretta installazione deve garantire il mantenimento delle performance dichiarate nella marcatura CE e testate in laboratorio. Si consiglia di progettare un corretto numero di fissaggi in relazione al tipo di contro telaio/muratura esistente e alle dimensioni degli elementi da installare. Al termine dell'installazione si verifichi il corretto funzionamento del serramento (facilità di apertura/chiusura, stabilità dell'anta aperta a riposo, etc.), il rispetto delle fughe e del sormonto tra ante apribili e telai fissi, il regolare posizionamento delle guarnizioni e delle sigillature, il drenaggio del giunto aperto e la mancanza di difetti estetici sulle superfici dei telai e del vetro.

General information

The systems designed and developed by Secco Sistemi are suitable for the manufacturing of a wide range of doors, windows and shutters, as well as faces or facades in metal. The systems are designed for professional and expert companies in the metal-working sector and that of construction of doors, windows, shutters and facades. These companies are well aware of the specific regulations and the directions and technical specifications of the system supplier, and also the fundamental rules of the art of manufacturing and installing these products. All the technical documentation provided furnishes a source of reference for the qualified technicians of the companies, giving indications as to how the products should be constructed. These qualified experts must critically analyse the indications to verify their adequacy for each single order in terms of load, stress and conditions of installation, particularly as this documentation cannot provide for all the different variations that may be found in projects.

Tolerance

EBE 85 is made by coupling external frames with the opening leaves with a distance of 12 mm on doors and 15 mm on windows. To ensure the correct functioning of hardware and gaskets, tooling must be performed with great care and precision. It is advised to keep the tolerance between +0/-1 mm for opening elements and between +0/+0.5mm for their overlapping area.

Cut / Processing

EBE 85 profiles in galvanized steel, stainless steel and corten steel can be cut with normal saws, like those used for steel pipes. EBE 85 profiles in brass can be cut with saws used for aluminium. Given their dimension and size, it is recommended to use the cutting jaws advised to ensure perfect stability during the cutting procedure. In order to verify the correctness of the cut, the tolerance of both the 45° and the 90° sections must be between -1°/+1°. All Tooling must be performed in line with this technical note and any variations agreed with Secco Sistemi's Technical Department.

Welding

EBE 85 profiles can be welded with the traditional systems (MIG/MAG, TIG), with an appropriate lubricating/cooling system and according to the instructions as per this technical note. Avoid welding near the thermal break joint. Heating any polyurethane items releases gaseous substances containing aldehydes and CO. For this reason it is recommended to weld with the special Personal Protective Equipment suggested and in areas with sufficient ventilation and fume-disposing systems. The corten profiles must be welded with special corten wire, while for profiles in brass a CuSi3 wire can be used. It is recommended to weld in depth, to avoid leaving any holes or porosity on the surfaces and to smooth and clean the welded surface thoroughly. This is to guarantee a proper structural resistance at the corner and to allow for later painting without any visible imperfections (pores and ripples).

Painting/Burnishing

EBE 85 profiles have been designed to be painted with the powder coating technique in industrial ovens at temperatures of 180°C for 25 minutes. The thermal break area is not designed to absorb polyester powders and therefore it's advised to cover the visible areas with appropriate industrial-oven-resistant adhesive films (SA1024 and SA1033). Holes must be drilled in the frames (as per instructions in these technical specifications) before painting or burnishing in order to allow drainage of any liquid used as a pre-treatment of the surfaces. Once out of the oven, the frames must be accurately removed and laid in a horizontal position until complete cooled.

It is advised to follow pre-treatment and painting cycles as outlined in the Secco Sistemi documentation.

Glass application

Glass needs to be secured internally and externally. Internally, glazing beads must be used together with clips or bushings and then secured by pressure with the appropriate gasket; externally a continuous perimetrical gasket should be applied, jointed and sealed in a top corner or a butyl seal and a thread of silicone that must be applied according to the product supplier's technical specifications. In order to ensure the correct functioning of the system, it is recommended to verify the proper pressurization of the internal glazing bead gaskets.

Installation

Proper installation must guarantee that the performances declared in the EC marking and verified in the lab will remain constant. It is advised to arrange a correct series of set ups with reference to the existing type of subframe/brickwork and to the dimensions of the elements to install. Once installation is completed, the proper functioning of the window/door (easiness of opening/closing, stability of the open leaf, etc.), should be tested as well as the correctness of joints and overlapping areas between opening leaves and fixed frames, the proper positioning of gaskets and seals, the drainage of frames with weep system and the absence of any aesthetic defects on the frame and glass surfaces.

AT1100

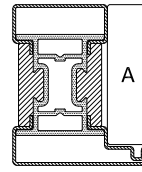
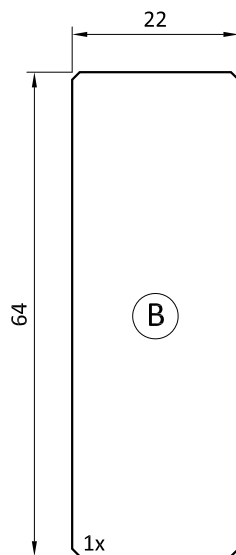
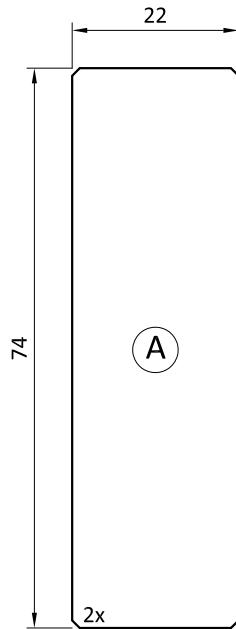

PR1101

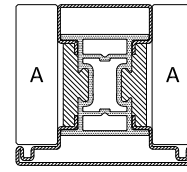

PR1102

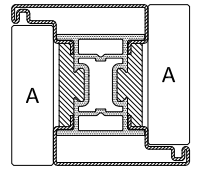

PR1103

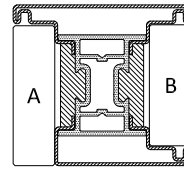

PR1105

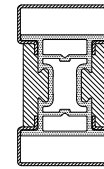

PR1110

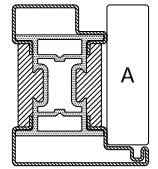

PR1111

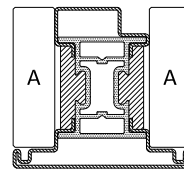

PR1112

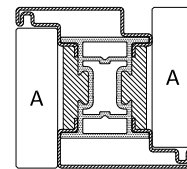

PR1113

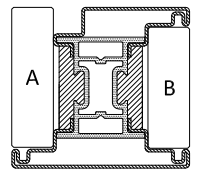

PR1115

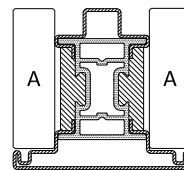

PR1122

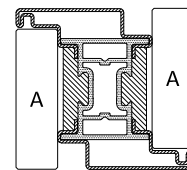

PR1123

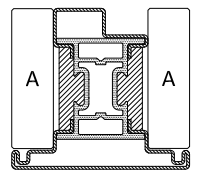

PR1127

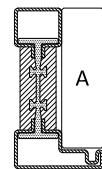

PR1301

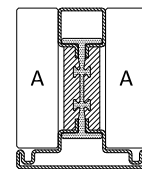

PR1302

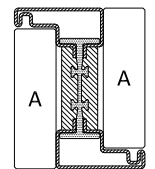

PR1303

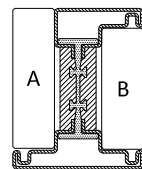

PR1305

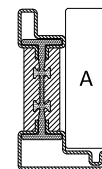

PR1311

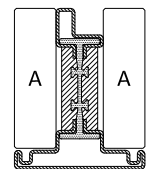

PR1312

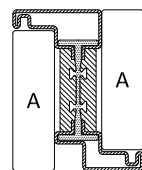

PR1313

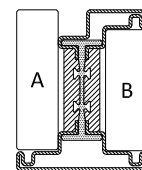

PR1315

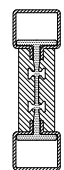

PR1320

AT1336

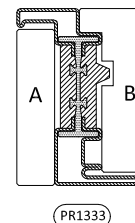
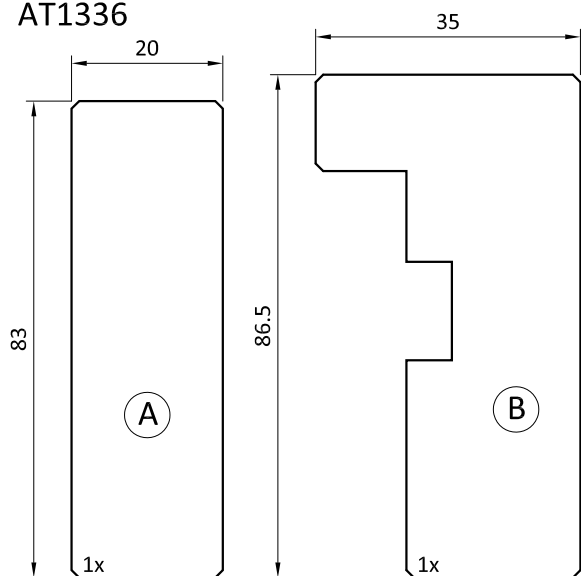

AT1924

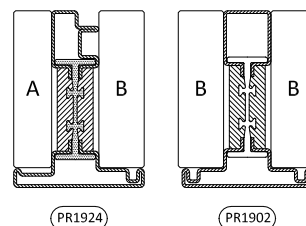
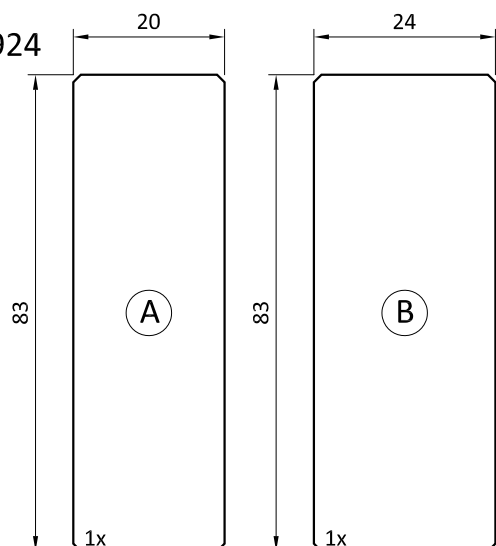

AT2029

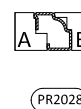
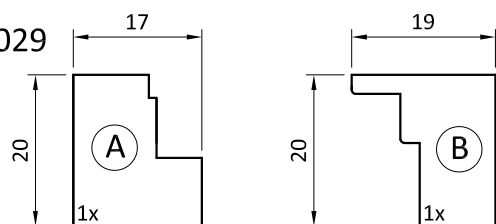

AT2038

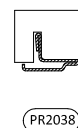
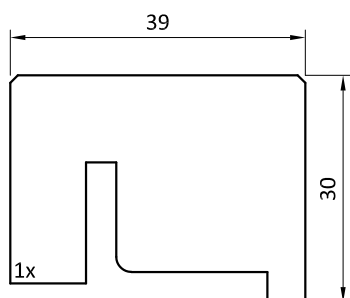

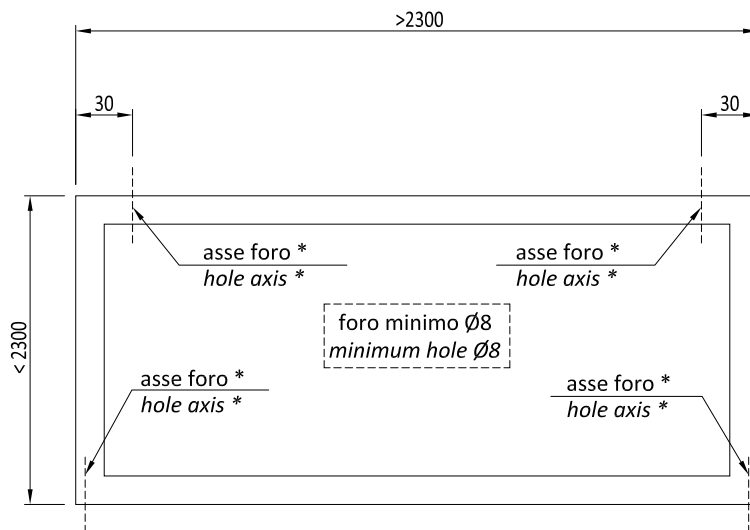
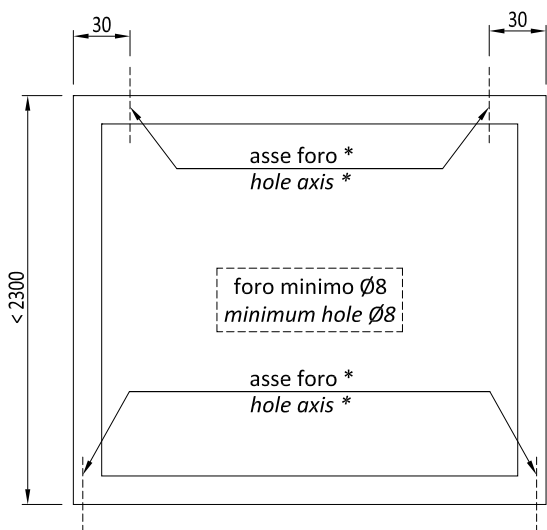

* forare alla massima estremità
* to be drilled on the extremity

N.B. dimensioni orientamento telai indicative - da verificare con l'impianto di verniciatura/brunitura scelto

N.B. frame dimensions are indicative - they have to be checked with the powder painting / burnishing plant

FORATURA LATO INFERIORE PER SCOLO LIQUIDI
DRILLING BOTTOM FRAME FOR LIQUID DRAINAGE

FORATURA LATO SUPERIORE PER APPENDERE
DRILLING UPPER FRAME FOR FRAME HANGING

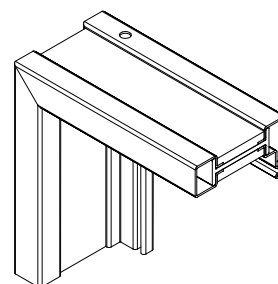
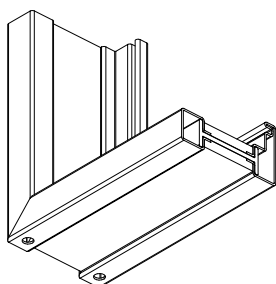
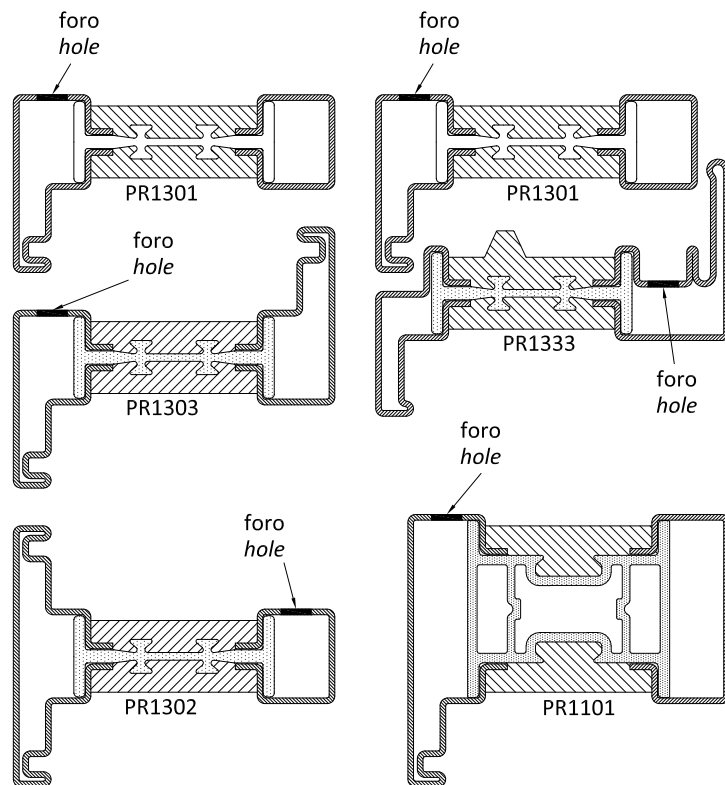
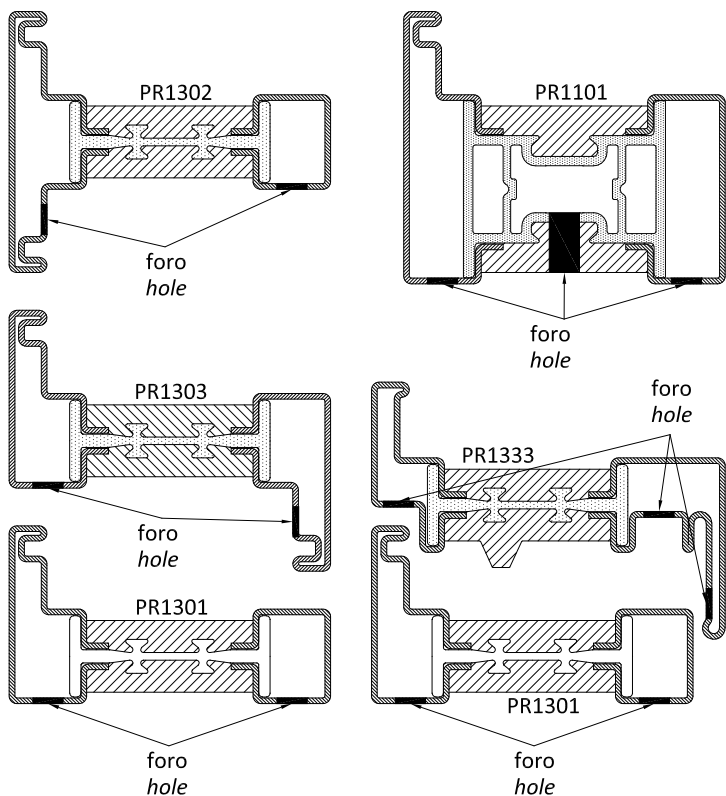

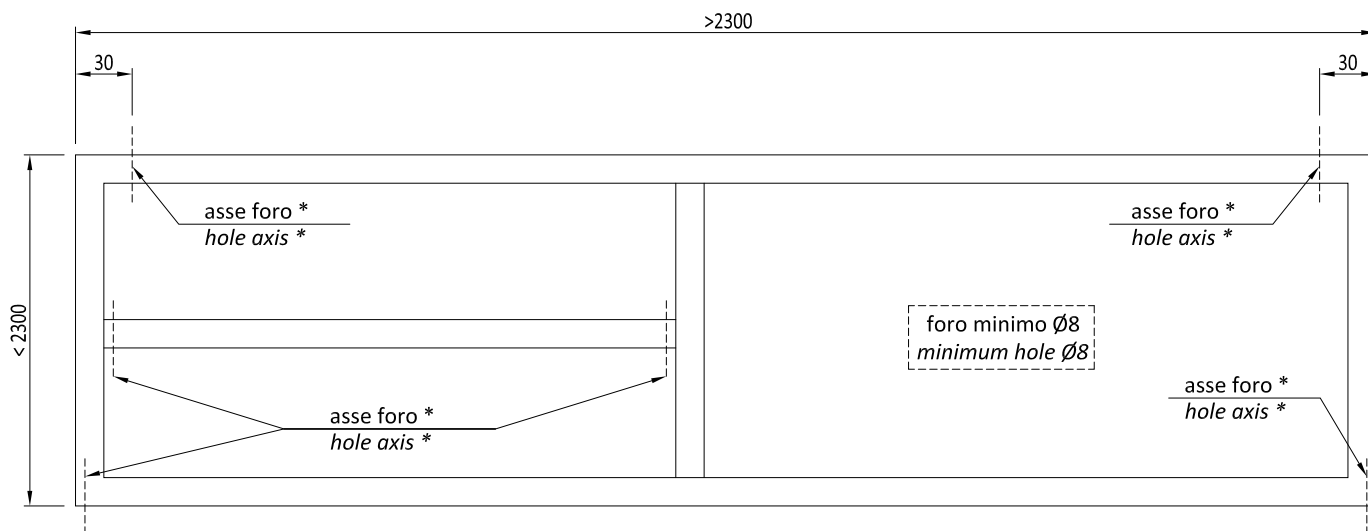

* forare alla massima estremità
* to be drilled on the extremity

N.B. dimensioni orientamento telai indicative - da verificare con l'impianto di verniciatura/brunitura scelto

N.B. frame dimensions are indicative - they have to be checked with the powder painting / burnishing plant

FORATURA MONTANTI
DRILLING MULLION

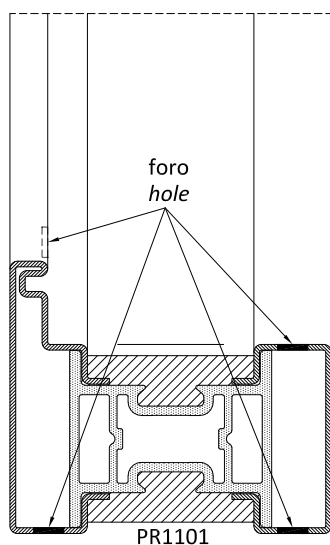
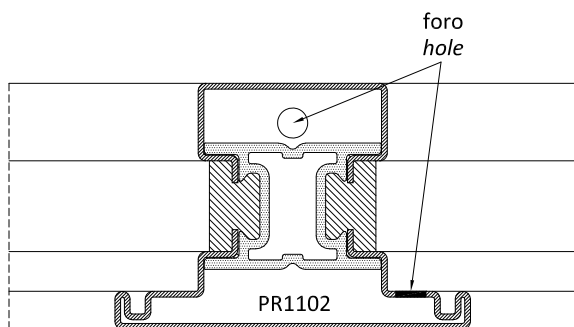

FORATURA TRAVERSI
DRILLING TRANSOM

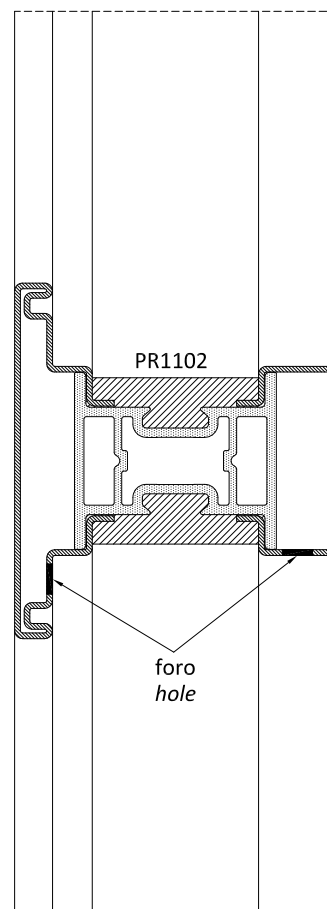

Troncatricecaratteristiche minime della macchina

- Potenza: 1.8 – 2.5 kW;
- Possibilità di taglio a 45° nei due sensi e a 90°;
- Velocità di taglio ideali: 15-30 giri/min per acciaio inox;
60-90 giri/min per acciaio zincato e corten,
90 giri/min o superiori per bronzo (OT/67);
- Capacità di taglio: 150 x 80 mm a 90°;
100 mm taglio a 45°.

caratteristiche della lama

- Lama da 350 mm con spessore 2.5 mm;
- N° denti: - 300 per tagli a 45°;
- 350 per tagli a 90°;
- Materiale: HSS (verificare materiali di commercio con finiture che migliorano la durata delle lame).

NB: è possibile tagliare la lega OT/67 con le stesse macchine dell'alluminio.

Pantografocaratteristiche minime della macchina

- Mandrino con velocità regolabile 2000-11000 giri/min (per un corretta lavorazione su acciaio inox è necessario operare a n° ridotto di giri < 4000);
- Struttura in ghisa adatta al taglio acciaio;
- Testata pesante per limitare le vibrazioni;
- Chiusura del profilo da lavorare con morse.

caratteristiche minime delle frese

- Materiale: HSS (verificare materiali di commercio con finiture che migliorano la durata delle frese);
- Frese a 4 denti;
- Frese con diametro 5 mm per le lavorazioni di scasso.

Foraturemontaggio componenti di chiusura e movimentazione sui profilati in acciaio inox

- Forare con punte da trapano HSS del diametro indicato sulla corrispondente tavola tecnica;
- Maschiare il foro con vite autofilettante zincocromata avente diametro corrispondente alla vite inox fornita nel kit con l'articolo da montare;
- Posizionamento e fissaggio definitivo dell'articolo con le viti inox in dotazione.

fresatura di cave e asole sui profili inox

- Adoperare macchine (pantografi o fresatrici) adeguate alle lavorazioni dell'acciaio;
- Regolazione del numero di giri max (3000 giri/1');
- Impiego di frese di diametro massimo di 8mm a 4 pale in acciaio HSS;
- Abbondare con la lubrificazione, concentrata sull'utensile;
- Ridurre l'avanzamento fino ad accertare un taglio il più regolare possibile;
- È normale un'usura accelerata dell'utensile.

CutterMinimum requirements for the use of the machine

- Power: 1.8 – 2.5 kW;
- Possibility of cutting at 45° in both directions and at 90°;
- Ideal cutting speed: 15-30 rmp for stainless steel;
60-90 rmp for galvanised and corten steel;
90 rmp or higher for bronze (OT/67);
- Cutting capability: 150 x 80 mm at 90°;
100 mm cut at 45°.

Blade specifications

- 350 mm blade with a 2.5 mm thickness;
- Number of teeth: 300 for 45° cut;
350 for 90° cut;
- Material: HSS (please verify availability of longer lasting material on the market).

Note: OT/67 alloy can be cut with machines made for aluminum.

PhantographMinimum requirements for the use of the machine

- Mandrel with a 2000-11000 rmp adjustable speed (for a proper stainless steel processing a slower speed is required i.e.<4000 rpm);
- Machine should be made of cast iron suitable for steel cutting;
- Heavy head in order to limit vibrations;
- Secure the profile to be processed in jaws.

Minimum requirements for the use of a milling machine

- Material: HSS (please verify availability of longer lasting material on the market);
- Use a 4-tooth milling machine;
- Use a milling machine with a 5-mm diameter for groove processing.

DrillingHow to mount closing and moving components on a stainless steel profile

- Use a HSS drill. The diameter of the drill is indicated in the technical note;
- Thread the hole with self-threading zinc-plated screws with the same diameter as the stainless steel screw provided with the kit;
- Position and secure the item with the stainless steel screws provided.

Milling slots and loops in the profiles

- Use machines designed for steel processing (pantographs or milling machines);
- Max rpm setting (3000 rpm);
- Use milling machines with a diameter no bigger than 8 mm and with 4 HSS steel blades;
- Exceed with lubrication, mainly on the machine;
- Processed slowly until the milling is as clean as possible;
- Expect a fast wearing of the machine.

1. Controllo materiale in arrivo / *Incoming equipment Control*

Verifica visiva dell'intergrità delle barre con attenzione a: / *Profiles wholeness visual control paying attention to:*

- Strisci profondi / *Deep scratches* verifica visiva / *visual control*
- Botte e avvallamenti sulla superficie / *Bumps and dips on surface* verifica visiva / *visual control*
- Rettilineità barre / *Profiles straightness tolerance* 0,002 x L
- Svergolamento / *Profiles twist tolerance* 1° x m

2. Taglio barre e controllo barre / *Cut and Control of profiles*

- Misura lunghezza / *Length measurement* ±0.5 mm
- Verifica 45° / *45° Control* ± 1°
- Verifica 90° / *90° Control* ± 1°

MATERIALI**ACCIAIO INOX****Materiale**

Profilati ricavati da nastro di lamiera di acciaio inox laminato a freddo pre-trattato industrialmente per garantire la massima qualità e uniformità.

Caratteristiche fisiche

AISI 316L Marino (X2 CrNiMo 17-12-2)

Norme di riferimento

EN 10088-2; EU 114

Trattamenti superficiali

Finitura satinata: ottenuta su nastro AISI 304 con finitura superficiale 2B con successiva satinatura con abrasivi a grana 240-280.

Finitura lucida: ottenuta su nastro AISI 316L (marino) con finitura superficiale 2R, riflettività 53% e successiva lucidatura a specchio.

Finitura Scotch Brite: ottenuta su nastro AISI 316L (marino) con finitura superficiale 2B con successiva spazzolatura Scotch Brite.

ACCIAIO COR-TEN**Materiale**

Profilati ottenuti da nastro in acciaio altoresistenziale, autopassivante (che un tempo veniva commercializzato con il nome Cor-Ten) tale da formare, se esposto all'aria, uno strato di ossido uniforme e stabile che, ricoprendo la lamiera, ne arresta la corrosione atmosferica.

Caratteristiche fisiche

Fe 510 X (C max % 0,12; Si % 0,25-0,75; Mn % 0,20-0,50; P % 0,07-0,15; Cu % 0,25-0,55; Cr % 0,30-1,25; Ni max % 0,65)

Norme di riferimento

EN 10149

Trattamenti superficiali

Dopo la profilatura il materiale viene immerso in speciali bagni ossidanti tali da accelerare la formazione dello strato protettivo. Raggiunta la tonalità desiderata della superficie si procede ad una ceratura di stabilizzazione del materiale.

ACCIAIO ZINCATO VERNICIATO**Materiale**

Profilati ottenuti da nastro in lamiera di acciaio zincato a caldo sistema Sendzimir finitura skinpassata

Caratteristiche fisiche

FeP02 GZ 200

Norme di riferimento

UNI EN 10142/3/7; EURONORM 143

Trattamenti superficiali per la verniciatura

La preparazione del supporto zincato si effettua tramite i processi di sgrassaggio, decapaggio e lavaggio in acqua. Segue l'applicazione di uno strato di zinco per fosfatazione seguito da lavaggi in acqua demineralizzata. Infine applicazione della mano a finire con polveri poliestere cotte in forno a 180 °C per 25 minuti.

LEGA DI RAME OT67**Materiale**

Profilati ottenuti da nastro di Lega di Rame OT67 laminato a freddo rincrudito allo stato grezzo.

Caratteristiche fisiche

Cu Zn 33 CW 506L (OT 67, 67% rame)

Norme di riferimento

EN 1652:1999

Trattamenti superficiali

Finitura brunita: dopo la profilatura viene eseguita una ricottura di distensione, quindi la pulitura meccanica con abrasivo e la successiva brunitura per immersione con liquido brunitore; il profilo viene poi lavato e asciugato ed infine protetto mediante trattamento con olio di vaselina.

Finitura lucida: dopo la profilatura viene eseguita una ricottura di distensione e successivamente la lucidatura a specchio.

MATERIALS**STAINLESS STEEL****Materials**

Sections processed out of the cold-rolled coils, industrially pre-treated for utmost quality and uniformity.

Physical features

AISI 316L Marino (X2 CrNiMo 17-12-2)

Norms of reference

EN 10088-2; EU 114

Surface treatment

Satined: obtained on AISI 304 coil 2B pre-finish with post-treatment by means of abrasive 240-280 in grain size.

Polished: obtained on AISI 316L (marine) coil pre-finish with 2R surface finish, 53% reflectivity, and mirror post-polish.

Scotch Brite: obtained on AISI 316L (marine) coil 2B pre-finish with Scotch-Brite post-scrubbing.

CORTEN STEEL**Materials**

Sections processed out of highly resistant self-oxidising steel coils – once traded under the name Cor-Ten. If exposed to the open air, it produces a uniform protective layer that reduces weather corrosion.

Physical features

Fe 510 X (C max % 0,12; Si % 0,25-0,75; Mn % 0,20-0,50; P % 0,07-0,15; Cu % 0,25-0,55; Cr % 0,30-1,25; Ni max % 0,65)

Norms of reference

EN 10149

Surface treatment

After forming, sections are plunged into a special oxydising bath to catalyze formation of the protective coating. Once the desired tone obtained, sections are stabilized by a wax coating.

GALVANIZED AND PAINTED STEEL**Materials**

Sections processed out of hot galvanized steel coils, band "Sendzimir, skinpassed finishing.

Physical features

FeP02 GZ 200

Norms of reference

UNI EN 10142/3/7; EURONORM 143

Pre-painted surface treatment

The preparation of a galvanised surface is made through several processes: degreasing, pickling and washing. A coating of zinc is then applied through a phosphatising process followed by rinses in demineralised water. A final coat is then applied with polyester powders baked at 180 °C for 25 minutes.

COPPER ALLOY OT67**Materials**

Sections processed out of copper alloy coils, industrially cold-rolled.

Physical features

Cu Zn 33 CW 506L (OT 67, 67% copper e 33% zinc)

Norms of reference

EN 1652:1999

Surface treatment

Burnished finish: after forming, the product is submitted to stress relieving, then to mechanical cleaning with abrasive products and ultimately to burnishing by plunging into a burnishing solution. It is then washed and dried and protected with a vaseline coating.

Glossy finish: after forming, the product is submitted to stress relieving and then mirror-like polished.

INDICE ANALITICO | SUBJECT INDEX

AC1001I	4.2.5	AC1237.xx	4.4.48-50
AC1002I	4.2.5	AC1355.xx	4.4.1
AC1003I	4.2.6	AC1356	4.4.15 4.4.56 4.4.71
AC1004I	4.2.7	AC1708I	4.2.19
AC1005I	4.2.8	AC1714.xx	4.4.3-5 4.4.9
AC1006I	4.2.8	AC1716G	4.4.7-9
AC1007I	4.2.9	AC1730I	4.2.17
AC1008I	4.2.9	AC1731I	4.2.14
AC1009I	4.2.6	AC1732I	4.2.15
AC1013I	4.2.7 4.2.10	AC1733I	4.2.16
AC1014.xx	4.3.1-2	AC1733IE	4.2.16
AC1020XL	4.3.44 4.4.72	AC1735I	4.2.14
AC1020XS	4.3.44 4.4.72	AC2608	2.9.11
AC1021	4.2.20	AC2632.C	4.4.51 4.4.62
AC1022	4.2.21	AC5002.SB	4.3.41
AC1023	4.2.22	AC5037	4.4.69
AC1024ID	4.2.10	AC5056	4.4.15 4.4.56 4.4.70
AC1024IS	4.2.10	AC6023	4.3.13
AC1033.xx	4.3.4-6	ACV942.xx	4.3.42
AC1033R	4.3.6	ACV943.xx	4.3.42
AC1037.xx	4.3.7-9	ACV944.xx	4.3.42
AC1037R	4.3.9	ACV947.xx	4.3.42
AC1039	4.4.64-65	ACV948.xx	4.3.42
AC1040	4.3.30	ACV949.xx	4.3.42
AC1046	4.4.66	ACV952.xx	4.3.43
AC1046M	4.4.67	ACV953.xx	4.3.43
AC1065W.D-S	4.3.15-17	ACV954.xx	4.3.43
AC1066W.D-S	4.3.15 4.3.18-19	ACV957.xx	4.3.43
AC1067W.D-S	4.3.20-22	ACV958.xx	4.3.43
AC1068.NE	4.3.10-12	ACV959.xx	4.3.43
AC1070	4.3.23 4.3.25-26	ACV970.xx	4.4.71
AC1071	4.3.24-26	ACV971.xx	4.4.71
AC1072	4.3.27-29	ACV972.xx	4.4.71
AC1075	4.3.23-29	ACV973.xx	4.4.71
AC1080I	4.3.14	ACV974.xx	4.4.71
AC1081.x	4.3.31-33	ACV976.xx	4.4.71
AC1081T	4.3.36 4.3.40	ACV977.xx	4.4.71
AC1201I	4.2.12	ACV979.xx	4.4.71
AC1202I	4.2.12 4.2.17	AG1224	4.4.61
AC1203I	4.2.13	AG1264.xx	4.4.55-57
AC1207I	4.2.18	AG1271-2-5-6.xx	4.4.14 4.4.19-21 4.4.38-42 4.4.45-46
AC1209I	4.2.13	AG1273.xx	4.4.13
AC1211I	4.2.23	AG1274.xx	4.4.55-56 4.4.58
AC1211IA	4.2.24	AG1278.xx	4.4.13
AC1219.xx	4.4.6-7	AG1281-2-5-6.xx	4.4.14 4.4.25-28 4.4.38-42 4.4.45-46
AC1219Y.xx	4.4.6-7	AG1291-2-5-6.xx	4.4.14 4.4.32-34 4.4.38-42 4.4.45-46
AC1221.xx	4.4.60	AG1385	4.4.52-53
AC1223I	4.4.63	AG1386	4.4.54
AC1231S	4.4.63	AG6530	4.4.47
AC1235	4.4.59	AGA271-5.xx	4.4.13 4.4.35-36 4.4.40-44

AGA775.xx	4.4.13 4.4.37 4.4.40-44
AGE271-2-5-6.xx	4.4.13 4.4.16-17 4.4.21 4.4.38-44
AGE775-6.xx	4.4.13 4.4.18 4.4.21 4.4.40-44
AGE281-2-5-6.xx	4.4.13 4.4.22-23 4.4.28 4.4.38-44
AGE785-6.xx	4.4.13 4.4.24 4.4.27 4.4.40-44
AGE291-2-5-6.xx	4.4.13 4.4.29-30 4.4.34 4.4.38-44
AGE795-6.xx	4.4.13 4.4.31 4.4.34 4.4.40-44
AT1100	5.1.4
AT1336	5.1.4
AT1924	5.1.4
AT2029	5.1.4
AT2038	5.1.4
CV5001.	2.9.11
CV5012.	2.9.11
GU1134	4.3.36 4.3.40
GU1311	4.4.64 4.4.68
PR1127	4.3.3
PR1129	4.3.37
PR1130	4.3.34-35 4.3.38-39
PR2027	4.4.11-12

METALFORM

MASTERS OF METAL

UNITED KINGDOM

METALFORM

NORWAYMETAL LTD

53 Chelsea Manor Street

London, SW3 5RZ

SALES@METALFORM.UK

+44 20 81298814

GERMANY

METALFORM GMBH

Carl-Zeiss-Ring 15A

85737 Ismaning

SALES@METALFORMGROUP.DE

+49 17663630406

NORWAY

METALFORM AS

Brochmannsveien 2

1950 Rømskog

SALG@METALFORM.NO

+47 401 62 446

METALFORMGROUP

SALES@METALFORMGROUP.COM